

Vickers®

# Check Valves



## Check Valves

Inline, right angle, manifold mounted, and pilot operated designs

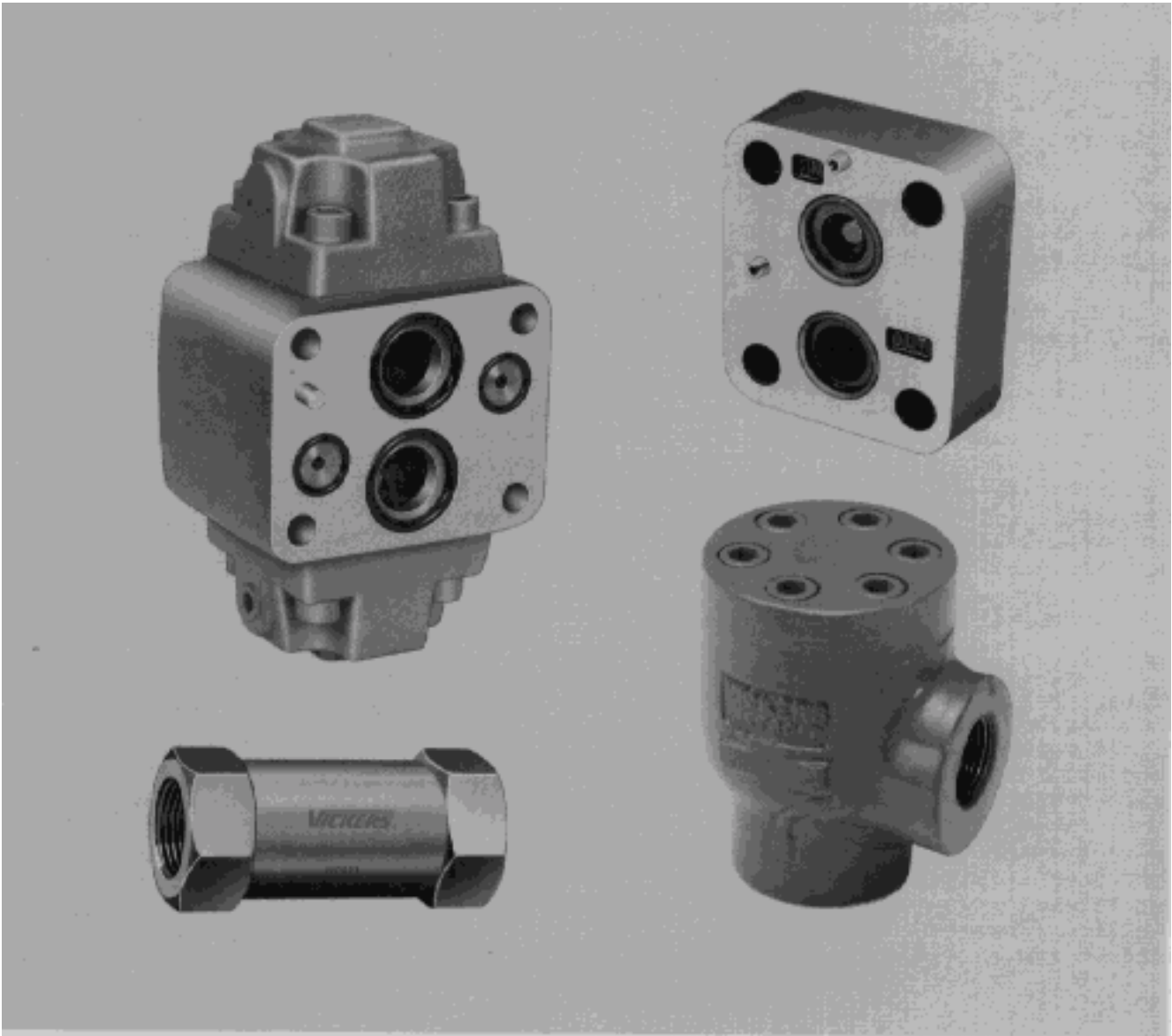

# Introduction

Vickers inline, right-angle, and manifold mounted check valves are *direct operated* and used in hydraulic circuits to allow the free flow of fluid in one direction only. The graphical symbol for these valves is a spring-loaded ball and a seat, as shown below.

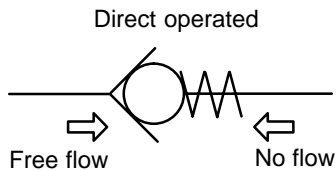

A light spring holds the valve poppet in its normally closed position. The valve starts to pass fluid at a pressure equivalent to the spring cracking pressure level. Various spring (cracking) pressures are available to suit application requirements.

All except inline models can be used for high velocity flows resulting in shock conditions. Inline models are designed for low shock service. *Inline check valves* can be used as a safety bypass for flow surges through filters and heat exchangers. With a higher spring rating, they can also be used as a means of generating pilot pressure.

*Right angle check valves* are designed for higher flows with less pressure drop. The valves' seat and poppet are of hardened and ground steel for improved cycle life. An orifice plug can be placed in the poppet to permit a restricted flow through the valve in its normally closed position; as such, these valves are typically used in controlling the rate of decompression in a large press before shifting the main valve.

*Pilot operated valves*, like direct operated valves, permit free flow in one direction and prevent flow in the reverse direction. However, pilot operated valves permit reverse flow when a pilot pressure signal is applied to the valve's pilot port. The graphical symbol for these valves is shown below. Pilot operated valves have very low internal leakage and are typically used to lock a cylinder in place until the main directional valve shifts.

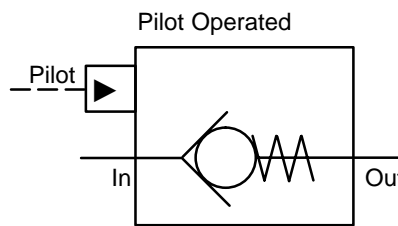

Note: Vickers also has a range of SAE flange mounted check valves, and ISO 4401-03 and -05 stackable check valves. Flange mounted models are described in publication 627. Size -03 and -05 stackable models are described in publications GB-C-2027 and GB-C-2022, respectively.

# Table of Contents

---

## **Inline Check Valves**

Model Code .....	4
Ratings and Specifications .....	4
Pressure Drop .....	4
Installation Dimensions .....	5
Typical Applications .....	5

## **Right Angle Check Valves**

Model Code .....	6
Ratings and Specifications .....	6
Installation Dimensions .....	7

## **Manifold Mounted Check Valves**

Model Code .....	8
Ratings and Specifications .....	8
Pressure Drop .....	8
Installation Dimensions .....	9

## **Pilot Operated Check Valves**

Model Code .....	11
Pilot Area and Cylinder Ratios .....	11
Ratings and Specifications .....	11
Installation Dimensions .....	12

## **Application Data, Ordering, and Service** ..... 15

- Hydraulic Fluids
- Seals
- Mounting Position
- Port Connections
- Fluid Cleanliness
- Ordering
- Service Information

# Inline Check Valves

## Model Code

**D\*8P1 - \*\* - \*\* - 1\***

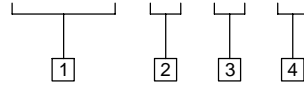

### 1 Model Series

DS8P1 – SAE straight threaded ports  
DT8P1 – NPTF pipe threaded ports

### 2 Nominal Size (in inches)

02 – 1/4 (not available in DS8P1 series)  
03 – 3/8  
06 – 3/4  
10 – 1-1/4

### 4 Design Number

10 – For “02” and “03” size  
11 – For “06” and “10” size  
Subject to change. Installation dimensions remain unchanged for designs 10 through 19.

### 3 Cracking Pressure

5 – 0,35 bar (5 psi)  
30 – 2,0 bar (30 psi)  
65 – 4,5 bar (65 psi)

## Ratings and Specifications

Model Series	Maximum Operating Pressure – bar (psi)	Flow Capacity l/min (USgpm)†	Approximate Weight – kg (lb)
DT8P1-02	210 (3000)	12 (3.2)	0,10 (.50)
D*8P1-03	210 (3000)	30 (8.0)	0,34 (.75)
D*8P1-06	210 (3000)	75 (20)	0,68 (1.5)
D*8P1-10	210 (3000)	200 (50)	2,70 (6.0)

† Using hydraulic oil with viscosity rating of 32 cSt (150 SUS) at 38°C (100°F).

## Pressure Drop

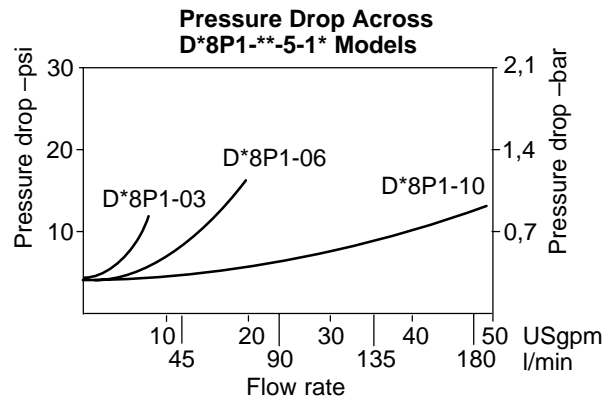

## Installation Dimensions Millimeters (Inches)

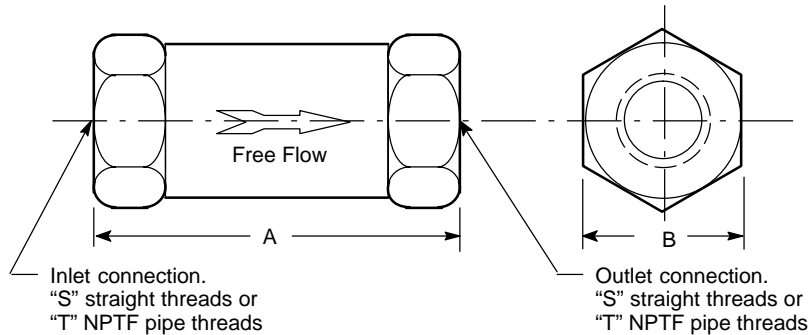

### CAUTION:

Do not use this valve to check a high velocity reverse flow resulting in shock conditions. (See typical applications below.) Where such conditions exist, Vickers C2-8\*\* or C5G-8\*\* type check valve should be used.

Model Series	A	B	"S" Straight Thread	"T" NPTF Pipe Thd.
DT8P1-02	57,2 (2.25)	22,4 (0.88)	—	1/4
D*8P1-03	76,2 (3.00)	25,4 (1.00)	.7500-16 UNF-2B	3/8
DT8P1-06	98,6 (3.88)	38,1 (1.50)	1.0625-12 UNF-2B	3/4
DS8P1-06	104,0 (4.09)	38,1 (1.50)	1.0625-12 UNF-2B	3/4
D*8P1-10	134,4 (5.25)	63,5 (2.50)	1.6250-12 UNF-2B	1-1/4

## Typical Applications

### D\*8P1 Inline Check Valve *Can Be Used*

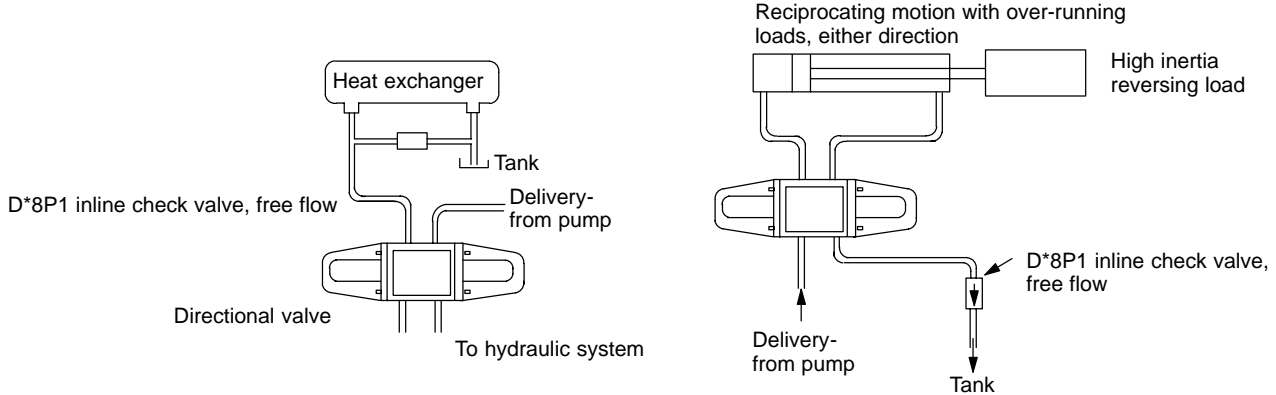

### C2-8\*\* or C5G-8\*\* Type Check Valve *Should Be Used*

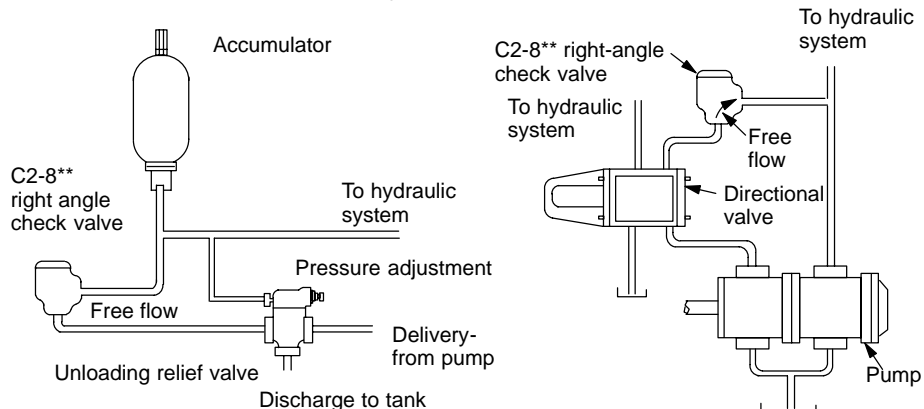

# Right Angle Check Valves

## Model Code

**C 2 (S) - 8 \*\* - (\*\*\*)**

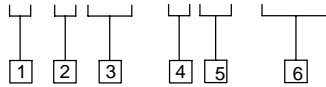

### 1 Check Valve

### 2 Design Number

Subject to change.

### 3 Port Threads

Blank – NPT threads  
S – Straight threads

### 4 Right Angle Type Valve

### 5 Port Size

00 – 1/4" NPT  
05 – 3/8" NPT or  
.7500-16 UNF-2B (.500 tubing)  
15 – 3/4" NPT or  
1.0625-12 UNF-2B (.750 tubing)  
20 – 1" NPT  
25 – 1-1/4" NPT or 1.6250-12 UNF-2B  
(1.250 tubing)  
30 – 1-1/2" NPT  
35 – 2" NPT

### 6 Cracking Pressure

Blank – 0,3 bar (5 psi), standard  
S2 – 2,4 bar (35 psi)  
S3 – 3,4 bar (50 psi)  
S8 – 5,2 bar (75 psi)  
S12 – 0,3 bar (5 psi) and plug in  
poppet. (See view below.)  
S17 – 8.6 bar (125 psi)  
S19 – 1,4 bar (20 psi)

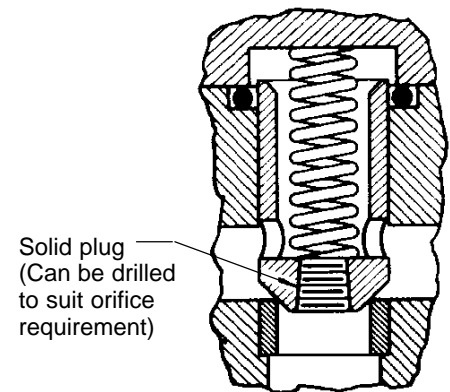

Construction of "S12" Cracking Pressures Model

## Ratings and Specifications

Model Series	Maximum Operating Pressure bar (psi)	Nominal Flow Capacity l/min (USgpm)	Approximate Pressure Drop at Rated Flow bar (psi) †	Approx. Weight kg (lb)
C2-800	210 (3000)	11 (3)	1,2 (18)	1,4 (3)
C2(S)-805	210 (3000)	25 (6)	1,4 (20)	1,4 (3)
C2(S)-815	210 (3000)	60 (16)	1,4 (20)	2,3 (5)
C2-820	210 (3000)	100 (28)	1,0 (14)	3,6 (8)
C2(S)-825	210 (3000)	170 (45)	1,0 (14)	4,8 (10.5)
C2-830	210 (3000)	250 (65)	1,6 (23)	4,8 (10.5)
C2-835	210 (3000)	400 (100)	1,4 (20)	12,2 (27)

† Using SAE 10W Oil at 49°C (120°F)

## Installation Dimensions

Millimeters (Inches)

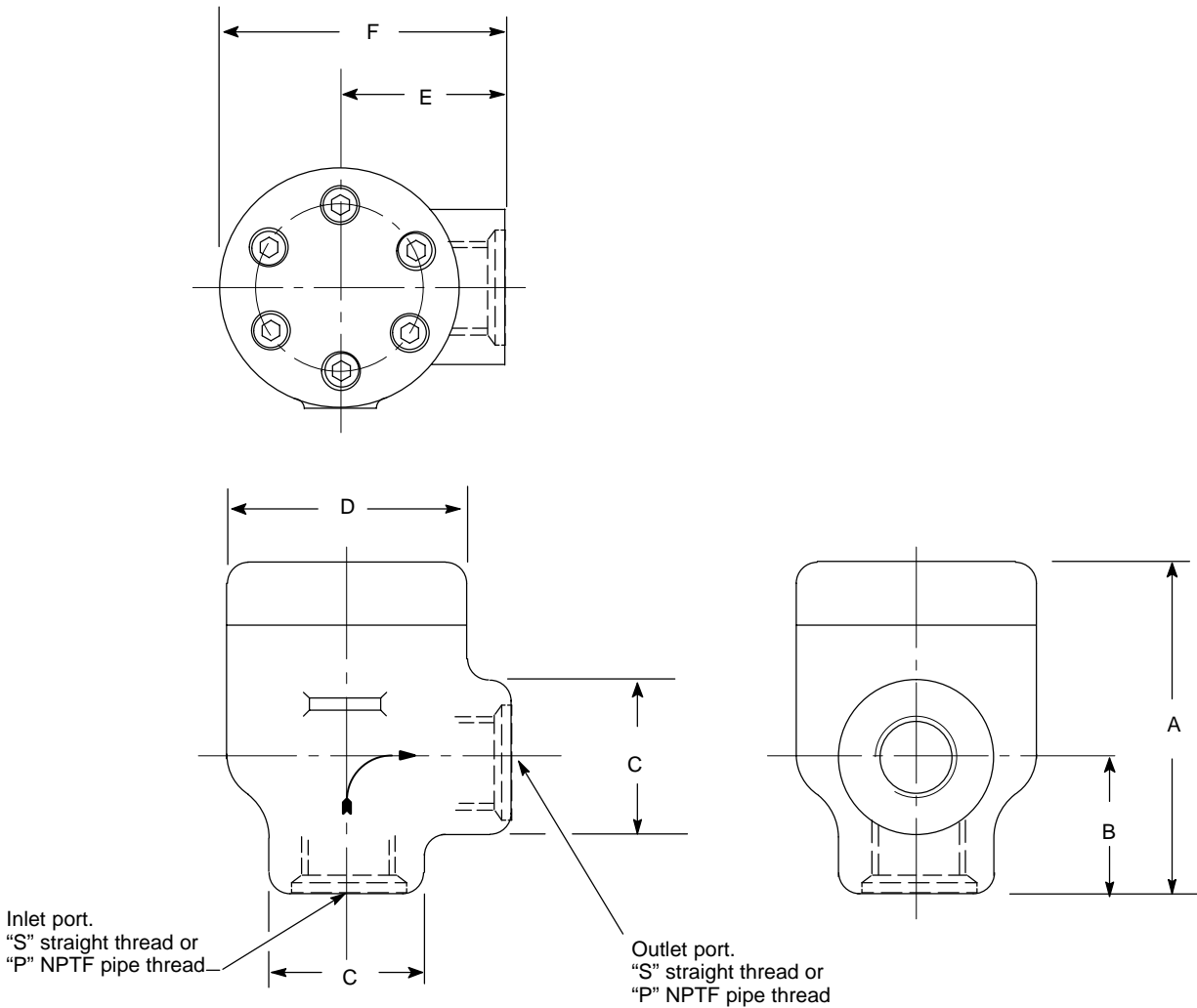

Model Series	"S" Straight Thread	"P" Pipe Thread	A	B	C	D	E	F
C2-800	—	1/4" NPT	74,7 (2.94)	26,1 (1.03)	31,8 (1.25)	53,8 (2.12)	31,8 (1.25)	58,7 (2.31)
C2(S)-805	.7500-16 UNF-2B	3/8" NPT	74,7(2.94)	26,1 (1.03)	31,8 (1.25)	53,8 (2.12)	31,8 (1.25)	58,7 (2.31)
C2(S)-815	1.0625-12 UNF-2B	3/4" NPT	98,6 (3.88)	44,4 (1.75)	50,8 (2.00)	69,8 (2.75)	46,0 (1.81)	81,0 (3,19)
C2-820	—	1" NPT	115,8 (4.56)	46,7 (1.84)	57,1 (2.25)	82,6 (3.25)	57,1 (2.25)	98,6 (3.88)
C2(S)-825	1.6250-12 UNF-2B	1-1/4" NPT	138,2 (5.44)	66,5 (2.62)	76,2 (3.00)	82,6 (3.25)	66,5 (2.62)	107,9 (4.25)
C2-830	—	1-1/2" NPT	138,2 (5.44)	66,5 (2.62)	76,2 (3.00)	82,6 (3.25)	66,5 (2.62)	107,9 (4.25)
C2-835	—	2" NPT	187,4 (7.38)	73,1 (2.88)	88,9 (3.50)	114,3 (4.50)	91,9 (3.62)	149,3 (5.88)

† Using SAE 10W Oil at 49°C (120°F)

# Manifold Mounted Check Valves

## Model Code

**(F3) - C 5 G - 8 \*\* - (\*\*)**

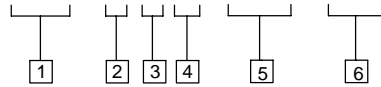

### 1 Special Seals

See "Seals" section on page 15.  
Omit for standard seals.

### 3 Design Number

Subject to change.

### 6 Cracking Pressure

Blank – 0,3 bar (5 psi), standard  
S3 – 3,4 bar (50 psi)  
S8 – 5,2 bar (75 psi)

### 2 Check Valve

### 4 Subplate or Manifold Mounted

### 5 Nominal Size

805 – 3/8" pipe or 1/2" tube  
815 – 3/4" pipe or 3/4" tube  
825 – 1-1/4" pipe or 1-1/4" tube

## Ratings and Specifications

Model Series	Maximum Operating Pressure bar (psi)	Nominal Flow Capacity l/min (USgpm)	Approximate Weight kg (lb)
C5G-805	210 (3000)	40 (10)	1,2 (2.7)
C5G-815	210 (3000)	75 (20)	2,9 (6.5)
C5G-825	210 (3000)	400 (100)	6,1 (13.5)

## Pressure Drop

### Pressure Drop for Free Flow Across Check Valve

Model Series	Flow Rate l/min (USgpm)	$\Delta P$ bar (psi)
C5G-805	18,9 (5)	0,9 (13)
	37,8 (10)	1,2 (17)
	56,8 (15)	1,5 (22)
	75,7 (20)	1,9 (27)
C5G-815	37,8 (10)	0,5 (7)
	75,7 (20)	1,0 (15)
	113,6 (30)	1,7 (25)
	151,4 (40)	2,4 (35)
C5G-825	94,6 (25)	0,6 (8)
	189,3 (50)	0,8 (12)
	283,9 (75)	1,1 (16)
	378,5 (100)	1,5 (22)
	473,2 (125)	2,1 (30)

1. Figures in the chart at left give approximate pressure drops ( $\Delta P$ ) when passing 21 cSt (100 SUS) fluid having .865 specific gravity.

2. For any other viscosity, pressure drop ( $\Delta P_1$ ) will be:

Viscosities – cSt (SUS)	14 (75)	32 (150)	43 (200)	54 (250)	65 (300)	76 (350)	86 (400)
% of $\Delta P$ (Approximate)	93	111	119	126	132	137	141

3. For any other specific gravity ( $G_1$ ), pressure drop ( $\Delta P_1$ ) will be approximately:  
 $\Delta P_1 = \Delta P (G_1/G)$ . (Obtain specific gravity figure from fluid producer; figure will be higher for fire-resistant fluids than for oil.)



## Installation Dimensions – C5G-805 Series

Millimeters (Inches)

### Mounting Bolt Kits

Mounting bolts must be ordered separately.

Example:

One (1) C5G-805 Check Valve  
One (1) BKCG-805-619 Bolt Kit

Bolt thread size is .375-16, and bolt length is 1.75 (both in inches). Maximum bolt torque is 35 Nm (26 lbf. ft.).

Mounting bolts, when provided by customer, must be SAE grade 7, or better.

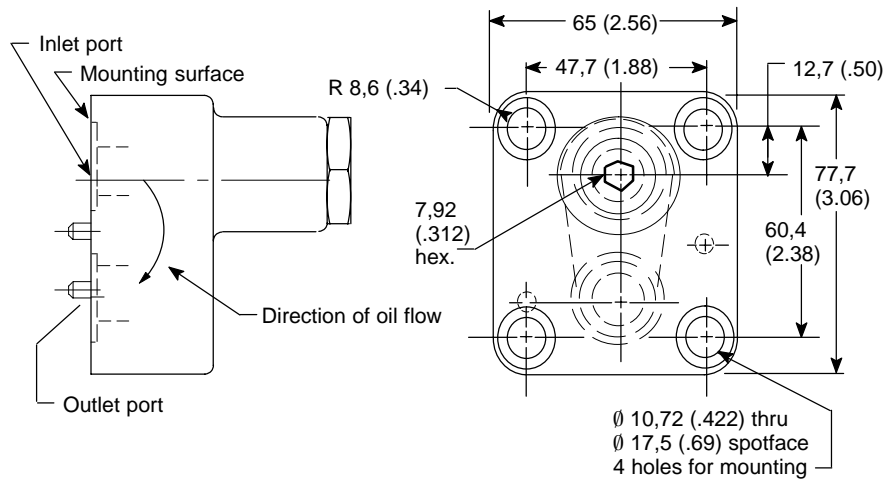
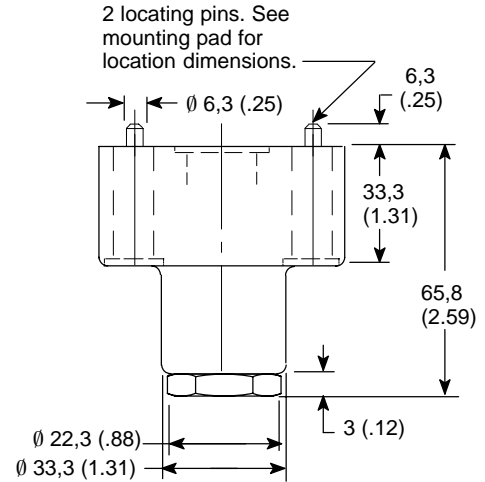

### Mounting Pad

A machined pad, as indicated by shaded area, must be provided for mounting. Pad must be flat within 0,013 mm (.0005 in.) and smooth within 1,6 micron (63 microinch).

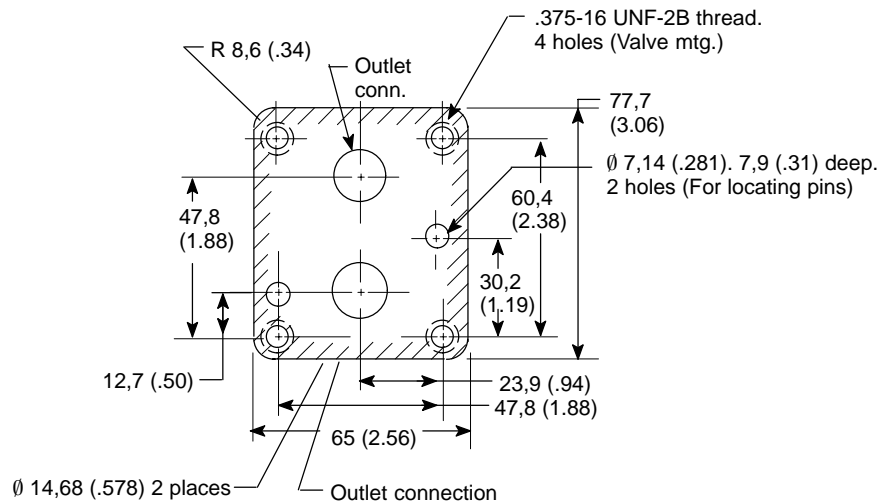

## Installation Dimensions – C5G-815 and C5G-825 Series

Millimeters (Inches)

### Mounting Bolt Kits

Mounting bolts must be ordered separately.

Valve Series	Bolt Kit	Bolt Thd. × Length
C5G-815	BKCG815-612	.625-11 × 1.75 inch
C5G-825	BKCG10-616	.750-10 × 3.50 inch

Maximum bolt torques are 47 Nm (35 lbf. ft.) and 95 Nm (70 lbf. ft.) for .625-11 and .750-10 bolts, respectively.

Mounting bolts, when provided by customer, must be SAE grade 7, or better.

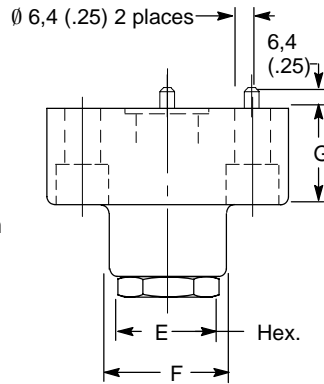

### Mounting Pad

A machined pad, as indicated by shaded area, must be provided for mounting. Pad must be flat within 0,013 mm (.0005 in.) and smooth within 1,6 micron (63 microinch).

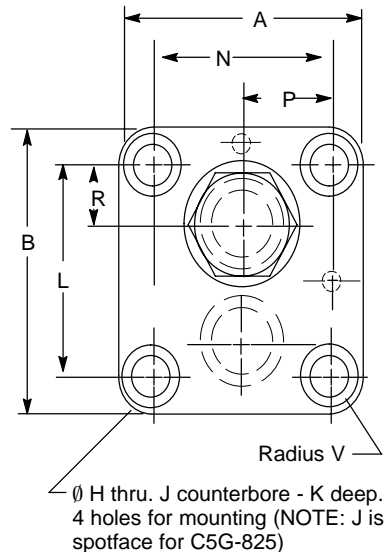
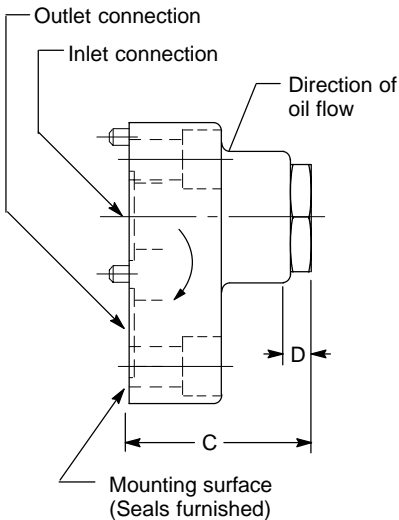
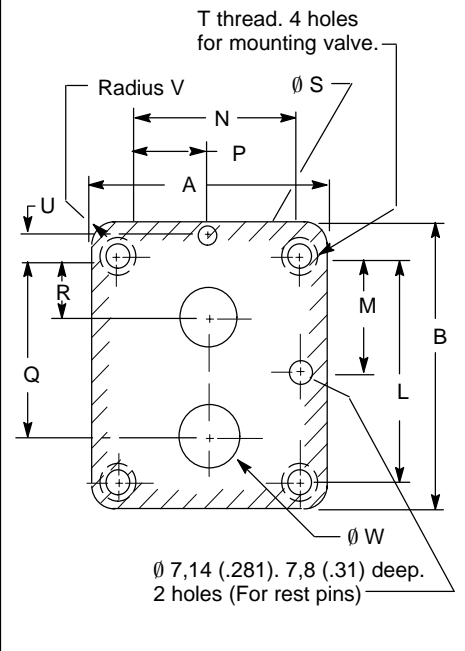

Model Series	A	B	C	D	E	F	G	H	J	K
C5G-815	96,8 (3.81)	112,8 (4.44)	76,2 (3.00)	11,2 (.44)	41,1 (1.62)	50,8 (2.00)	38,1 (1.50)	16,66 (.656)	25,4 (1.000)	15,7 (.62)
C5G-825	127 (5.00)	127 (5.00)	110,2 (4.34)	10,4 (.41)	47,7 (1.88)	66,5 (2.62)	57,9 (2.28)	19,84 (.781)	30 (1.18)	–

Model Series	L	M	N	P	Q	R	S	T	U	V	W
C5G-815	81 (3.19)	40,4 (1.59)	65 (2.56)	32,5 (1.28)	68,3 (2.69)	22,3 (.88)	23,01 (.906)	.625-11 UNC-2B	8,6 (.34)	15,7 (.62)	23,01 (.906)
C5G-825	91,9 (3.62)	46 (1.81)	91,9 (3.62)	46 (1.81)	71,4 (2.81)	20,6 (.81)	34,92 (1.375)	.750-10 UNC-2B	9,6 (.38)	17,5 (.69)	28,6 (1.125)

# Pilot Operated Check Valves

## Model Code

**(F3) - 4C \* - \*\* - (D) \* - 2\***

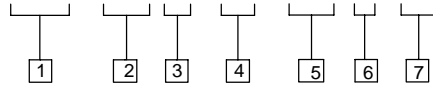

### 1 Special Seals

See "Seals" section on page 15.  
Omit for standard seals.

### 2 Check Valve

### 3 Mounting Type

G – Manifold or subplate  
S – SAE straight thread  
T – NPTF thread

### 4 Nominal Valve Size

03 – 3/8" pipe or 1/2" tubing  
06 – 3/4" pipe or 3/4" tubing  
10 – 1-1/4" pipe or 1-1/4" tubing

### 5 Decompression Poppet

D – With decompression.  
Omit if not required.  
(See "Pilot Area and Cylinder Ratios" section below.)

### 6 Cracking Pressure

A – 2 bar (30 psi)  
C – 5 bar (75 psi)  
F – 10 bar (150 psi)

### 7 Design Number

20 – For 4CG models  
21 – For 4CS and 4CT models  
Subject to change. Installation dimensions remain unchanged for designs 20 through 29.

## Pilot Area and Cylinder Ratios

The ratio between a check valve's pilot pressure area and poppet area must be greater than the ratio between a hydraulic cylinder's piston and annulus areas. If it is not, the valve will not open to permit reverse flow. For example, if the cylinder has a piston-to-annulus area ratio of 2:1, the valve must have a greater (3:1) ratio.

With large check valves or large differential-area cylinders, the valve's ratio may be difficult to achieve. For these cases, a decompression-type check valve, which can have an opening ratio of 30:1 or greater, can be used.

A decompression poppet (within the main poppet) is much smaller than the check valve's pilot piston and is seated

in a "through" hole in the pilot-piston end of the main poppet. The decompression poppet opens first, reducing the pressure behind the main poppet that is holding the main poppet closed. When this pressure is low enough, the pilot piston pushes the main poppet into the "open" position to allow full reverse flow.

## Ratings and Specifications

Model Series	Maximum Operating Pressure bar (psi)	Nominal Flow Rating l/min (USgpm)	Area Ratio		Pressure Drop bar (psi) †		"C" in Formula Below
			Pilot Piston Area to Decompression Poppet Area	Pilot Piston Area to Check Valve Area	●	●●	
4C*-03-A	210 (3000)	50 (12)	30:1	3.11:1	1,7 (25)	3,8 (55)	14
4C*-03-C	210 (3000)	50 (12)	30:1	3.11:1	1,7 (25)	6,2 (90)	21
4C*-03-F	210 (3000)	50 (12)	30:1	3.11:1	1,7 (25)	13,1 (190)	58
4C*-06-A	210 (3000)	100 (30)	48.2:1	3.12:1	2,7 (40)	4,5 (65)	09
4C*-06-C	210 (3000)	100 (30)	48.2:1	3.12:1	2,7 (40)	9,0 (130)	22
4C*-06-F	210 (3000)	100 (30)	48.2:1	3.12:1	2,7 (40)	15,8 (230)	43
4C*-10-A	210 (3000)	300 (75)	77:1	2.6:1	3,4 (50)	3,4 (50)	12
4C*-10-C	210 (3000)	300 (75)	77:1	2.6:1	3,4 (50)	8,3 (120)	29
4C*-10-F	210 (3000)	300 (75)	77:1	2.6:1	3,4 (50)	13,8 (200)	58

† Approximate pressure drop at rated flow. ● Valve held open by pilot pressure. ●● Free flow across poppet.

### Formula

Pilot pressure to crack decompression poppet or check valve:

$$\text{Pilot Pressure} = \frac{\text{"P" Out} - \text{"P" In}}{\text{Area Ratio}} + \text{"P" In} + C$$

Where: "P" Out = Pressure at free flow outlet  
"P" In = Pressure at free flow inlet  
C = Figure from chart above

### Directional Valve Compatibility

Directional valves with their cylinder ports open to tank in the center position (Vickers spool types 0, 6, 9, and 33) are recommended for use with 4C\* series check valves.

# Installation Dimensions – 4CG Series

Millimeters (inches)

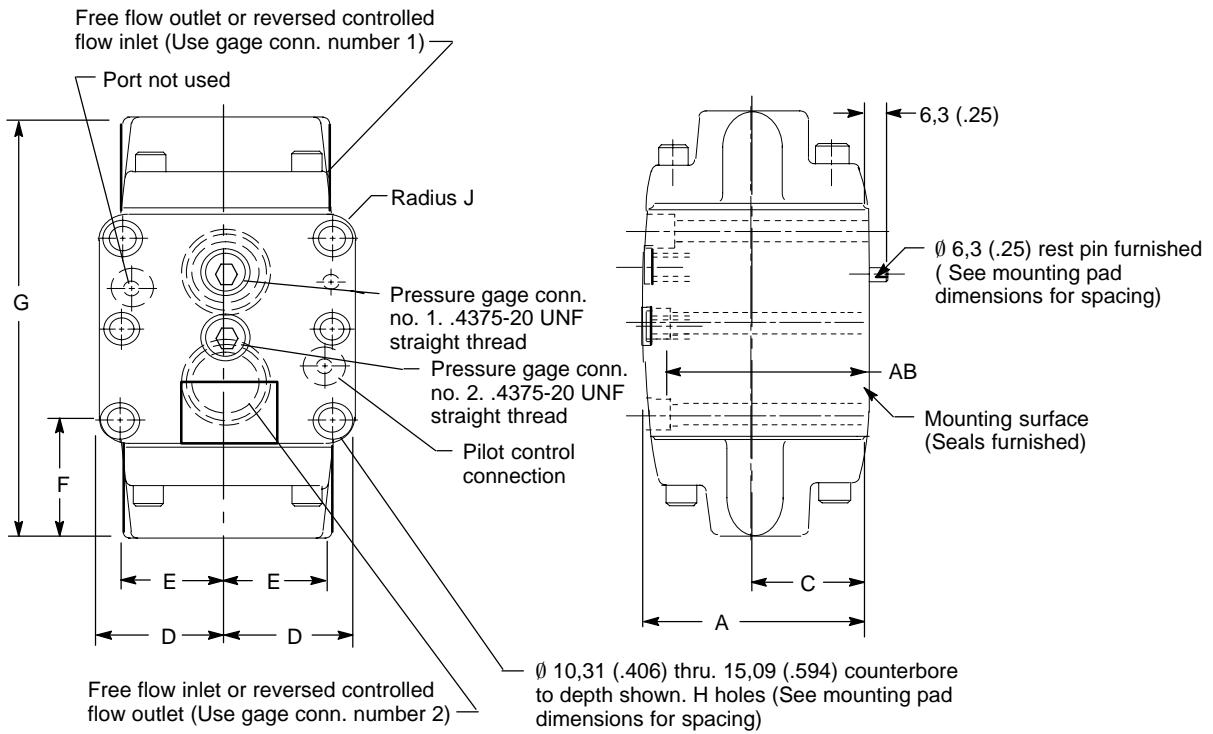

Model Series	A	C	D	E	F	G	H	J	AB	Approx. Weight kg (lb)
4CG-03	68,1 (2.68)	36,6 (1.44)	43,7 (1.72)	28,4 (1.12)	39,6 (1.56)	122,2 (4.81)	4	10,4 (.41)	55,9 (2.20)	3,6 (8)
4CG-06	78,5 (3.09)	41,4 (1.63)	50,8 (2.00)	35 (1.38)	55,6 (2.19)	171,7 (6.76)	4	11,2 (.44)	68,6 (2.70)	6,8 (15)
4CG-10	100,1 (3.94)	50,8 (2.00)	58,7 (2.31)	47,7 (1.88)	54,9 (2.16)	193,5 (7.62)	6	10,4 (.41)	90,2 (3.55)	11,8 (26)

# Installation Dimensions Subplates and Bolt Kits for 4CG Valves

Millimeters (inches)

Valve Series	Subplate	Bolt Kit
4CG-03	RXGM-03S-20	BKRX-03-660
4CG-06	RXGM-06SX-20	BKRX-06-661
4CG-10	RXGM-10S-30	BKRX-10-662

Bolt Kit	Bolt Thread Size × Length
BKRX-03-660	.375-16 × 2.75 inch
BKRX-06-661	.375-16 × 3.25 inch
BKRX-10-662	.375-16 × 4.00 inch

Valves, subplates, and mounting bolts must be ordered separately.

When subplate is not used, machined pad must be provided for mounting. Pad must be flat within 0,013 mm (.0005 in.) and smooth within 1,6 micron (63 microinch).

Mounting bolts, when provided by customer, must be SAE grade 7, or better.

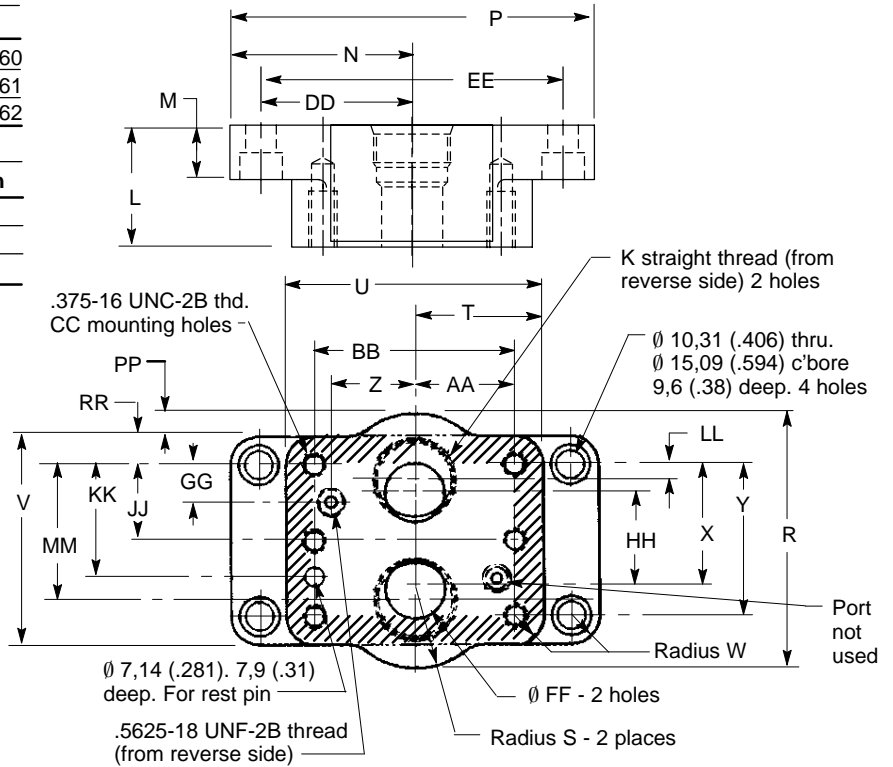

\*\* RXGM-03 and -06 use 4 valve mounting bolts. RXGM-10 uses 6 bolts.

Subplate Model	K	Tube O. D.	L	M	N	P	R	S	T	U	V	W	X	Y	Z
RXGM-03S--20	.7500-16 UNF-2B	1/2"	25,4 (1.00)	19 (.75)	63,5 (2.50)	127 (5.00)	76,2 (3.00)	23,9 (.94)	43,7 (1.72)	87,4 (3.44)	63,5 (2.50)	10,4 (.41)	35,8 (1.41)	42,9 (1.69)	25,4 (1.00)
RXGM-06SX-20	1.3125-12 UN-2B	1"	31,7 (1.25)	19 (.75)	73,1 (2.88)	146 (5.75)	117,3 (4.62)	39,6 (1.56)	50,8 (2.00)	101,6 (4.00)	82,5 (3.25)	11,2 (.44)	49,3 (1.94)	60,4 (2.38)	33,3 (1.31)
RXGM-10S-30	1.6250-12 UN-2B	1-1/4"	47,7 (1.88)	22,3 (.88)	79,2 (3.12)	158,7 (6.25)	146 (5.75)	47,7 (1.88)	58,7 (2.31)	117,3 (4.62)	104,6 (4.12)	10,4 (.41)	67,6 (2.66)	84,1 (3.31)	44,4 (1.75)

Subplate Model	AA	BB	CC	DD	EE	FF	GG	HH	JJ **	KK	LL	MM	PP	RR	Approx. Weight kg (lb)	NFPA Interface
RXGM-03S-20	33,3 (1.31)	66,5 (2.62)	4	53,1 (2.09)	106,4 (4.19)	14,2 (.56)	21,3 (.84)	28,4 (1.12)	-	31,7 (1.25)	4,8 (.19)	38,1 (1.50)	6,3 (.25)	10,4 (.41)	1,5 (3.25)	P03
RXGM-06SX-20	39,6 (1.56)	79,2 (3.12)	4	62 (2.44)	123,9 (4.88)	23,1 (.91)	20,6 (.81)	38,1 (1.50)	-	44,4 (1.75)	6,3 (.25)	53,8 (2.12)	17,5 (.69)	11,2 (.44)	2,9 (6.50)	P06
RXGM-10S-30	48,5 (1.91)	96,8 (3.81)	6	69,1 (2.72)	138,2 (5.44)	28,4 (1.12)	24,6 (.97)	50,8 (2.00)	42,2 (1.66)	62,7 (2.47)	7,9 (.31)	76,2 (3.00)	20,6 (.81)	10,4 (.41)	5 (11)	P10

## Installation Dimensions – 4CS and 4CT Series

Millimeters (Inches)

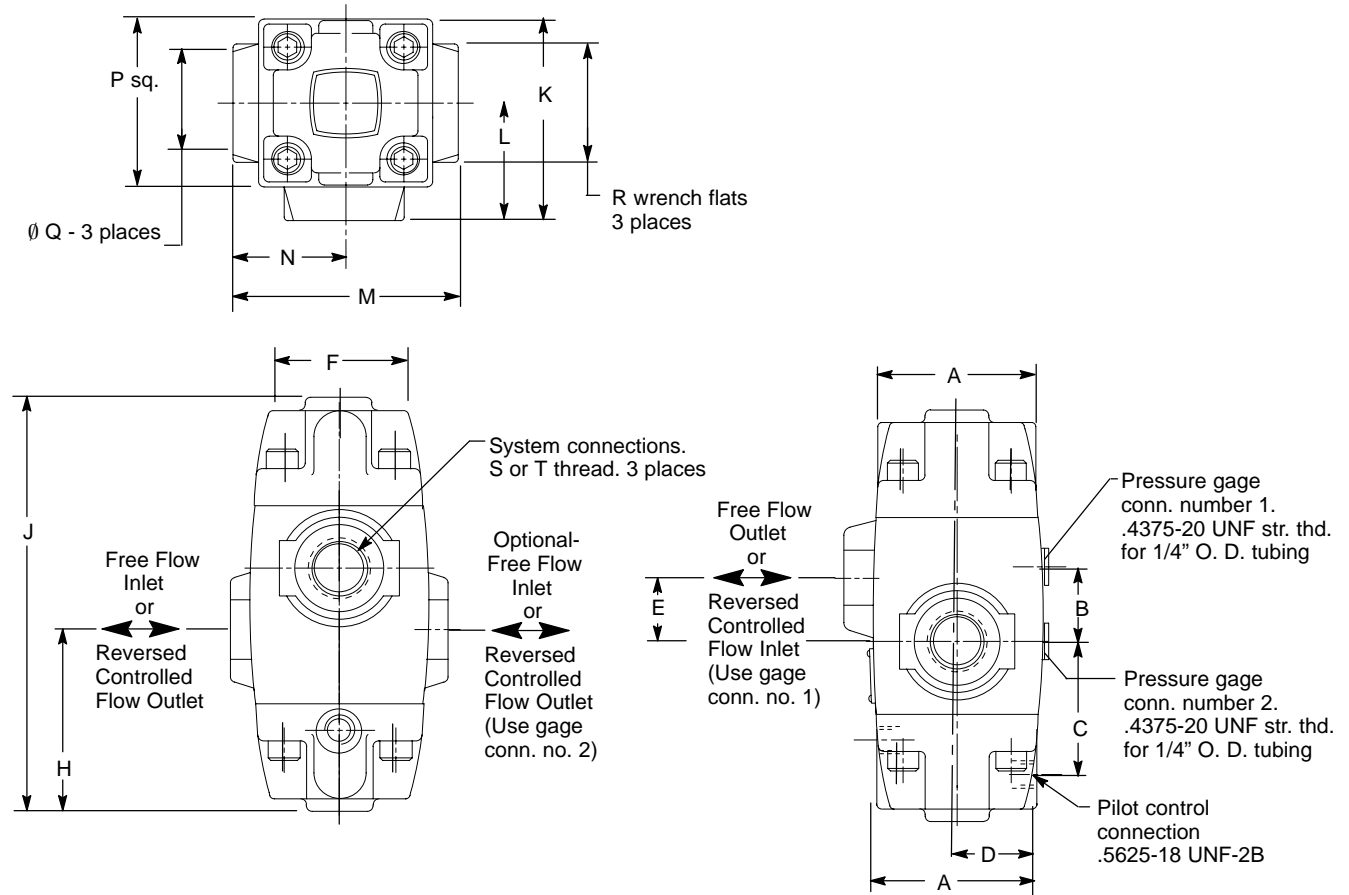

Model Series	A	B	C	D	E	H	J	K	L
4C*-03	57,1 (2.25)	24,1 (.95)	45,2 (1.78)	28,4 (1.12)	23,1 (.91)	53,1 (2.09)	122,2 (4.81)	69,8 2.75	39,6 1.56
4C*-06	70,1 (2.76)	31,7 (1.25)	57,1 (2.25)	35 (1.38)	26,9 (1.06)	74,7 (2.94)	171,4 (6.75)	88,6 (3.49)	50,8 (2.00)
4C*-10	95,2 (3.75)	29,2 (1.15)	77,8 (3.10)	47,7 (1.88)	28,9 (1.14)	84,1 (3.31)	193,8 (7.63)	117,8 4.64	68,3 2.69

Model Series	M	N	P	Q	R	S Straight Thread	T NPTF Thread	Approx. Weight kg (lb)
4C*-03	70,9 (2.79)	35 (1.38)	59,4 (2.34)	35 (1.38)	35 (1.38)	.7500-16 UNF-2B	3/8	2,7 (6)
4C*-06	95,2 (3.75)	47,7 (1.88)	75,7 (2.98)	47,7 (1.88)	50,8 (2.00)	1.0625-12 UN-2B	3/4	5,7 (12.5)
4C*-10	107,9 (4.25)	53,8 (2.12)	99,1 (3.90)	82,5 (3.25)	86,4 (3.40)	1.6250-12 UN-2B	1-1/4	12 (26.5)

# Application Data, Ordering, and Service

## Hydraulic fluids

Valves can be used with anti-wear hydraulic oil, or automotive type crankcase oil (designations SC, SD, SE, SF, or SG) per SAE J183 JUN89. Fire-resistant fluids can also be used, but may require the use of special seals as explained in the following "Seals" section.

A fluid viscosity ranging between 32 cSt (150 SUS) and 48,5 cSt (225 SUS) at 38°C (100°F) is recommended.

## Seals

Inline check valves have no elastomer seals, so they can be used with petroleum or fire-resistant fluids. Nitrile (Buna N) seals are standard in other Vickers check valves, except certain pilot operated models described below. These seals are suitable for use with petroleum and water-glycol fluids, and water-in-oil emulsions.

Synthetic fire-resistant fluids require the use of Viton™ seals, which are identified in model codes by an "F3" prefix. These seals are standard in pilot operated 4CS and 4CT models, so the prefix need not be added. (Viton is a registered trademark of E.I. DuPont Co.)

## Mounting position

The mounting position of valves is not limited because of their spring closure construction.

## Port connections

Straight-threaded or flanged O-ring connections are less likely to leak, compared to taper-threaded (NPT) connections, and are recommended.

## Fluid cleanliness

Proper fluid condition is essential for long and satisfactory life of hydraulic components and systems. Hydraulic fluid must have the correct balance of cleanliness, materials and additives for protection against wear of components, elevated viscosity and inclusion of air.

Essential information on the correct methods for treating hydraulic fluid is included in Vickers publication 561; "Vickers Guide to Systemic Contamination Control," available from your local Vickers distributor or by contacting Vickers, Incorporated. Recommendations on filtration and the selection of products to control fluid condition are included in 561.

Recommended cleanliness levels, using petroleum oil under common conditions, are based on the highest fluid pressure levels in the system and are coded in the chart below. Fluids other than petroleum, severe service cycles or temperature extremes are cause for adjustment of these cleanliness codes. See Vickers publication 561 for exact details.

Vickers products, as any components, will operate with apparent satisfaction in fluids with higher cleanliness codes than those described. Other manufacturers will often recommend levels above those specified. Experience has shown, however, that life of any hydraulic components is shortened in fluids with higher cleanliness codes than those listed below. These codes have been proven to provide a long trouble-free service life for the products shown, regardless of the manufacturer.

## Ordering

Order each valve by complete model number to ensure size and cracking pressure are as required. If needed, a mounting subplate, and/or bolt kit, must be ordered separately:

Example:

One (1) 4CG-06-A-21 Valve  
One (1) RXGM-06SX-20 Subplate  
One (1) BKRX-06-661 Bolt Kit

## Service information

Refer to following parts drawings for service information:

Model Series	Drawing
C2-8**	I-0632-S
C2S-8**	I-3612-S
C5G-805	I-3582-S
C5G-815/825	I-3578-S
DS8P1	I-0953-S
DT8P1	I-0953-S
4CG-03	I-3579-S
4CG-06	I-3580-S
4CG-10	I-3581-S
4CS/4CT-03	I-3681-S
4CS/4CT-06	I-3682-S
4CS/4CT-10	I-3683-S

## Cleanliness codes for petroleum oil usage

Product	System Pressure Level		
	< 2000 psi	2000-3000 psi	3000+ psi
Vane pumps, fixed	20/18/15	19/17/14	18/16/13
Vane pumps, variable	18/16/14	17/15/13	
Piston pumps, fixed	19/17/15	18/16/14	17/15/13
Piston pumps, variable	18/16/14	17/15/13	16/14/12
Directional valves	20/18/15	20/18/15	19/17/14
Check valves	20/18/15	20/18/15	20/18/15
Proportional valves	17/15/12	17/15/12	15/13/11
Servo valves	16/14/11	16/14/11	15/13/10
Pressure / Flow controls	19/17/14	19/17/14	19/17/14
Cylinders	20/18/15	20/18/15	20/18/15
Vane motors	20/18/15	19/17/14	18/16/13
Axial piston motors	19/17/14	18/16/13	17/15/12
Radial piston motors	20/18/14	19/17/13	18/16/13