

SPATENBOHRER

SPADE DRILLS



2.3



WARUM SPATENBOHRER · WHY SPADE DRILLS

Reduzieren Sie Ihre Kosten pro Bohrung durch Karnasch Spatenbohrer

Spatenbohrer sind das Hauptprodukt von Karnasch im Bereich Bohrer mit auswechselbaren Schneidköpfen. Spatenbohrer sind hocheffiziente Bohrwerkzeuge mit herausragenden Leistungsparametern. Spatenbohrer ersetzen die veraltete Bohrtechnik der komplett aus HSS / HSS-Co Kobalt / Pulverstahl bestehenden Bohrwerkzeuge. Spatenbohrer sind eine hervorragende Ergänzung für den Bereich Vollhartmetallbohrer. Spatenbohrer bestehen aus 2 Teilen – Halter und Schneideinsätze.

Die Vorteile sind:

- 1 Es werden nur 14 Halter benötigt um den Durchmesserbereich Ø 9,5 – 114 mm abzudecken.
- 2 Innere Kühlmittelzufuhr für hervorragende Spanabfuhr auch bei tiefen Bohrungen.
- 3 Die hochpräzise Verbindung zwischen Halter und Schneideinsatz gewährleistet engste Toleranzen und leicht zu wechselnde Schneideinsätze.
- 4 Die Schneideinsätze sind aus Pulverstahl oder Hartmetall gefertigt, in Toleranz h8. Zusätzlich erhalten alle Schneideinsätze eine auf Ihren Einsatzzweck optimierte Beschichtung. Aus dieser Kombination resultieren wesentlich höhere Schnittleistungen / Standzeiten als bei konventionellen Bohrwerkzeugen. (Einsatzparameter siehe Seite 1304-1311)
- 5 Durch schnellen Austausch der Schneideinsätze ist der Spatenbohrer sofort wieder einsatzbereit. Nicht nötig (wie bei konventionellen Vollstahl-Bohrern) den kompletten Bohrer zur Aufarbeitung / Schärfen zu schicken.
- 6 Die optimierte XR-Schneidkante an den Schneideinsätzen reduziert erheblich die Zerspanungskräfte.
- 7 Unter anderem verfügen alle Schneideinsätze über eine „Spanbrecher-Funktion“ welche nochmals die Stabilität während des Bohrvorgangs erhöht.

Reduce your drilling cost by using KARNASCH spade drill

Spade drill is one of the main interchangeable insert drill from KARNASCH. It is a high efficient drilling tool with superior performance, designing to substitute those traditional hole drilling products with low efficiency and inconvenient usage. It consists of two parts – holder and inserts.

Its advantages are:

- 1 Only 14 holders can meet the demand for drilling holes from Ø 9.5 to Ø 114 mm.
- 2 Inner cooling design of holder enable excellent chip removal and good cooling when drilling deep holes.
- 3 High accuracy of the connections between the inserts and holders ensures high clamping accuracy, and easy to replace inserts.
- 4 Inserts are made of powder high speed steel or carbide, in tolerance h8, combined with various coatings. This improves extremely the tool life and drilling speed in comparison to normal twist drills (see cutting data page 1304-1311).
- 5 Replaceable structure, which is more convenient. No need of regrinding drill on the scene.
- 6 New type XR edge reduce the cutting resistance greatly.
- 7 Inserts have the function of chip-breaker, which improves the stability of holes drilling.

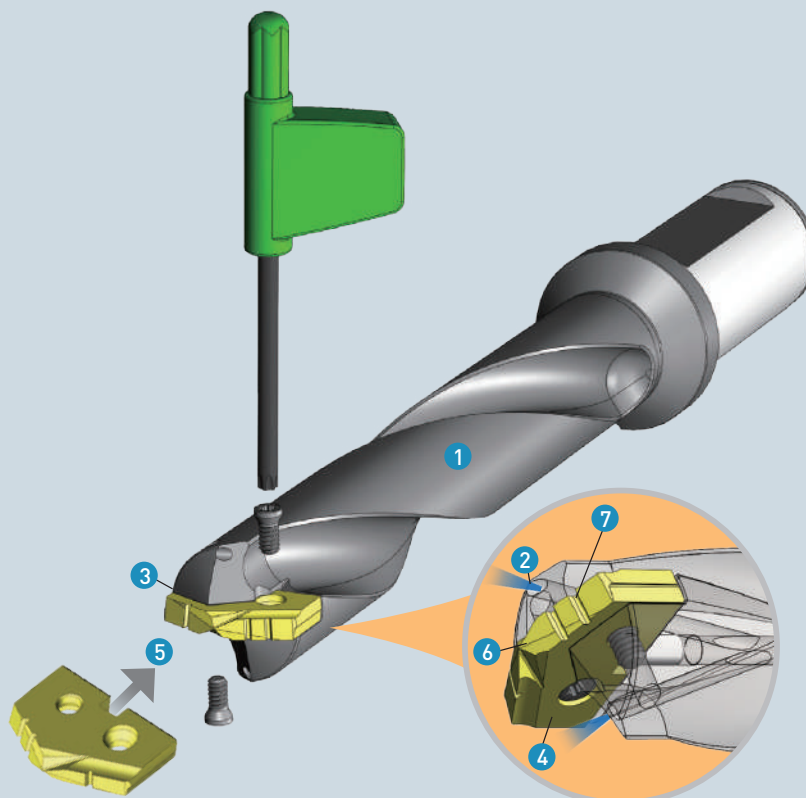

WARUM SPATENBOHRER · WHY SPADE DRILLS

Spatenbohrer sind das ideale Bohrwerkzeug für alle modernen CNC-Maschinen wie zum Beispiel:

- Numerisch gesteuerte Säulenbohrmaschinen / Radialbohrmaschinen
- Numerisch gesteuerte Drehmaschinen
- Bearbeitungszentren

Vorzugsweise werden hier Hartmetall-Einsätze angewendet

Spade drill is the perfect drilling tool match all kinds of modern CNC machines such as:

- Numerically controlled planar drill
- Numerically controlled lathe
- Machining centers

Preferably carbide insert are applied



Spatenbohrer sind das ideale Bohrwerkzeug für alle traditionellen / manuellen Bohrmaschinen wie zum Beispiel:

- Säulenbohrmaschinen
- Radialbohrmaschinen
- Alle Arten von vertikalen Bohrmaschinen
- Nicht numerisch gesteuerte Drehmaschinen

Vorzugsweise werden hier Pulverstahl-Einsätze angewendet

Spade drill is the perfect drilling tool match all kinds of traditional / manual drilling machines such as:

- Pillar drilling machines
- Radial drilling machines
- Vertical driller
- Non numerically controlled lathe

Preferably powder steel insert are applied



BESCHREIBUNG DES EINSATZES · DESCRIPTION OF INSERT MODEL

Spanbrecher

- Durch Spanbrecher bessere Spanabfuhr sowie weniger Schnittkräfte.

Chip breaker

- Chip breaking, better chip removal
- Reduce drilling torque

Beschichtung

Alle Einsätze erhalten spezielle Beschichtungen

Coating

All inserts receives special coatings

Spanteilerrillen

- Reduziert die Spanlänge.
- Dadurch bessere Spanabfuhr sowie reduzierte Schnittkräfte.

Chip dividing groove

- Reduce cutting width
- Better chip removal
- Reduce drilling torque

Durchmesser-Fase

- Verbessert die Stabilität des Schneideinsatzes.
- Reduziert den Verschleiß des Außendurchmessers am Schneideinsatz.
- Verbessert die Oberfläche am Werkstück.

Diameter chamfer

- Increase the strength of insert
- Reduce the wear & tear of outer diameter
- Improve the smoothness on the surface of workpiece

Bohrerspitze

- Durch ausgespitzte Zentrumsschneiden werden die axialen Kräfte bis zu 20% gegenüber konventionellen Bohrern reduziert.

Core drilling

- Thinner core drilling, which reduce 20% axial resistance compared with normal drilling products.
- Better self-centering

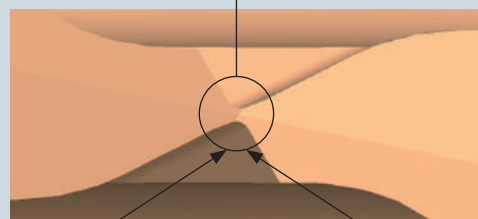

XR-Querschneid-Schliff

- Verbessert die Stabilität der Schneidkanten.
- Verbessert im Allgemeinen nochmals die Stabilität des gesamten Schneideinsatzes.

Zwei Rückenflankenflächen

- Reduziert die Reibung mit dem Werkstück.
- Verbessert die Selbstzentrierung.
- Reduziert die axialen Kräfte.

XR chisel edge regrinding

- Improve the strenght of cutting edges
- Increase the stability

Two back flank surfaces

- Reduce the friction with the workpiece
- Better self-centering
- Reduce the axial resistance

Befestigungsbohrungen

- Sichere und zuverlässige Befestigung der Schneideinsätze für höchste Stabilität während des Bohrvorgangs.

Positionierungs-Nut

- Gewährleistet die akkurate Positionierung der Schneideinsätze bei der radialen Drehbewegung.

Location groove

- Ensure the accuracy of the radial direction

Fix screw holes

- Safe and reliable clamping
- Ensure the stability during drilling

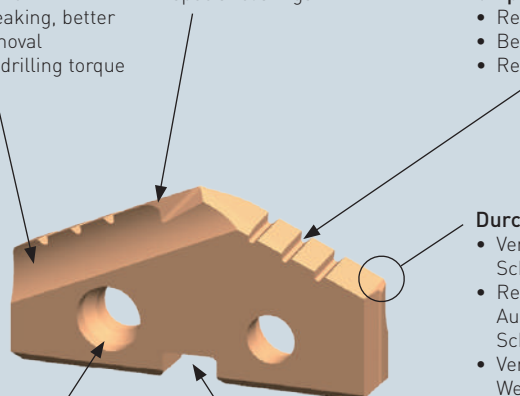











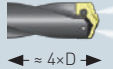
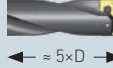
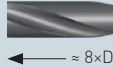

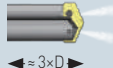
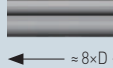
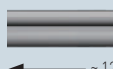

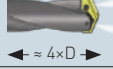
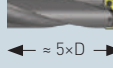
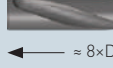

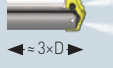
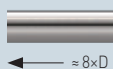

PULVERSTAHL-EINSÄTZE ANWENDUNG · POWDER STEEL INSERTS APPLICATION

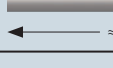
 <p>132°</p> <p>Ø 9,5-65 mm Ø 0.374-2.559"</p>	<p>22 2010</p> <p>Pulverstahl 25 STEEL-TEC beschichtet Für Edelstahl, Stahl, Guss</p> <p>Powder steel 25 STEEL-TEC coated For stainless steel, steel, cast iron</p> <p>STAHL Edelstahl GG/G cast iron</p>	<p>Zum Bohren der meisten Stähle, Gusseisen bis zu einer Härte von 400 HBW (1365 Nmm²). Passen ebenfalls zu: Allied Maxcut (AMEC), YG-1, ARNO-Shark-Drill</p>	<p>For drilling almost all sorts of steel, cast iron up to a hardness of 400 HBW (1365 Nmm²). Also suitable for: Allied Maxcut (AMEC), YG-1, ARNO-Shark-Drill</p>
 <p>144°</p> <p>Ø 64-114 mm Ø 2.520-4.488"</p>	<p>22 2510</p> <p>Pulverstahl 15 STEEL-TEC beschichtet Für legierte Stähle, Edelstahl, Stahl, Guss</p> <p>Powder steel 15 STEEL-TEC coated For alloy steel, stainless steel, steel, cast iron</p> <p>STAHL Edelstahl GG/G cast iron</p>	<p>Zum Bohren der meisten Stähle, Gusseisen bis zu einer Härte von 350 HBW (1180 Nmm²). Passen ebenfalls zu: Allied Maxcut (AMEC), YG-1, ARNO-Shark-Drill</p>	<p>For drilling almost all sorts of steel, cast iron up to a hardness of 350 HBW (1180 Nmm²). Also suitable for: Allied Maxcut (AMEC), YG-1, ARNO-Shark-Drill</p>
 <p>132°</p> <p>Ø 9,5-65 mm Ø 0.374-2.559"</p>	<p>22 3010</p> <p>Pulverstahl 25 ALU-TEC beschichtet Für Alu, Messing, Kupfer</p> <p>Powder steel 25 ALU-TEC coated For alu, brass, copper</p> <p>Aluminium MESSING Kupfer Bronze</p>	<p>Speziell zum Bohren aller Nicht-Eisen-Metalle wie Aluminium, Messing, Kupfer, Bronze ... Passen ebenfalls zu: Allied Maxcut (AMEC), YG-1, ARNO-Shark-Drill</p>	<p>Special for drilling all non ferrous metals such as aluminum, brass, copper, bronze ... Also suitable for: Allied Maxcut (AMEC), YG-1, ARNO-Shark-Drill</p>
 <p>144°</p> <p>Ø 64-114 mm Ø 2.520-4.488"</p>	<p>22 3510</p> <p>Pulverstahl 15 ALU-TEC beschichtet Für Alu, Messing, Kupfer</p> <p>Powder steel 15 ALU-TEC coated For alloy steel, steel, cast iron</p> <p>Aluminium MESSING Kupfer Bronze</p>	<p>Speziell zum Bohren aller Nicht-Eisen-Metalle wie Aluminium, Messing, Kupfer, Bronze ... Passen ebenfalls zu: Allied Maxcut (AMEC), YG-1, ARNO-Shark-Drill</p>	<p>Special for drilling all non ferrous metals such as aluminum, brass, copper, bronze ... Also suitable for: Allied Maxcut (AMEC), YG-1, ARNO-Shark-Drill</p>

HARTMETALL-EINSÄTZE ANWENDUNG · CARBIDE INSERTS APPLICATION

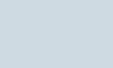
 <p>132°</p> <p>Ø 9,5-35 mm Ø 0.374-1.378"</p>	<p>22 4010</p> <p>Hartmetall 20/30 STEEL-TEC beschichtet Für Edelstahl, hochfester Stahl, gehärteter Stahl</p> <p>Carbide 20/30 STEEL-TEC coated For stainless steel, high strength alloys, hardened steel</p> <p>HRC < 52 INOX Edelstahl</p>	<p>Zum Bohren von Automatenstahl, für Stähle mit mittlerem und niedrigem Kohlenstoffgehalt, Stahllegierungen, Werkzeugstahl, Hochfeste und gehärtete Stähle. Passen ebenfalls zu: Allied Maxcut (AMEC), YG-1, ARNO-Shark-Drill</p>	<p>For drilling in free machining steel, in low and medium carbon steel, alloy steel, tool steel, high strength alloys, hardened steel. Also suitable for: Allied Maxcut (AMEC), YG-1, ARNO-Shark-Drill</p>
 <p>132° Guss Cast iron</p> <p>Ø 9,5-35 mm Ø 0.374-1.378"</p>	<p>22 4510</p> <p>Hartmetall 20/30 STEEL-TEC beschichtet Für alle Gussarten</p> <p>Carbide 20/30 STEEL-TEC coated For all kinds of cast iron</p> <p>INCOSEL HASTELLOY TITANIUM GJL GJS INOX Edelstahl</p>	<p>Zum Bohren von Hochtemperatur- und Titanlegierungen, Gusseisen mit Kugelgraphit (schmiedbares Gusseisen), SG-Gusseisen, Grau- und Weißgusseisen, spezielle rostfreie Stähle. Passen ebenfalls zu: Allied Maxcut (AMEC), YG-1, ARNO-Shark-Drill</p>	<p>For drilling in high-temperature and titanium alloys, all sorts of cast iron (nodular, grey, ductile cast iron), special stainless steels. Also suitable for: Allied Maxcut (AMEC), YG-1, ARNO-Shark-Drill</p>
 <p>132°</p> <p>Ø 9,5-35 mm Ø 0.374-1.378"</p>	<p>22 5010</p> <p>Hartmetall 20/30 ALU-TEC beschichtet Für Alu, Messing, Kupfer</p> <p>Carbide 20/30 ALU-TEC coated For alu, brass, copper</p> <p>Aluminium < 12% Si Kupfer Ampco MESSING</p>	<p>Zum Bohren aller Nicht-Eisen-Metalle wie Aluminiumguss, Schmiedealuminium, Aluminiumbronze, Messing, Kupfer. Passen ebenfalls zu: Allied Maxcut (AMEC), YG-1, ARNO-Shark-Drill</p>	<p>For drilling in all non ferrous metals such as cast aluminum, wrought aluminum, aluminum bronze, brass, copper. Also suitable for: Allied Maxcut (AMEC), YG-1, ARNO-Shark-Drill</p>
 <p>132°</p> <p>Ø 9,5-35 mm Ø 0.374-1.378"</p>	<p>22 5510</p> <p>Hartmetall 20/30 DIA-TEC beschichtet Für abrasive Materialien wie: GFK, CFK, Graphit</p> <p>Carbide 20/30 DIA-TEC coated For abrasive materials such as: fiberglass, carbon fiber, graphite</p> <p>CFK CFRP CFK CFRP GRAPHIT</p>	<p>Speziell zum Bohren abrasiver Materialien wie Glasfaser- und Kohlefaserwerkstoffe (GFK, CFK) sowie Graphit. Passen ebenfalls zu: Allied Maxcut (AMEC), YG-1, ARNO-Shark-Drill</p>	<p>Special for drilling in abrasive materials such as glass fiber, carbon fiber (GFK, CFK), graphite and similar. Also suitable for: Allied Maxcut (AMEC), YG-1, ARNO-Shark-Drill</p>

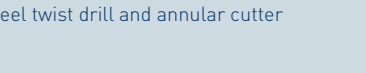
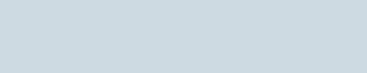
Detaillierte Anwendung siehe Seite 1304-1311 · Detailed application see page 1304-1311

BESCHREIBUNG DER WERKZEUGHALTER · DESCRIPTION OF HOLDER MODELS		×D	Ø mm + Schnitttiefe Ø mm + cutting depths					
 <p>Schaft DIN 1835-B Zylindrischer Schaft mit Spannfläche</p> <p>Spiral genutet Bohrer rotiert, Werkstück steht still. Z.B. Säulenbohrmaschinen, Radialbohrmaschinen. Spiralgenutete Werkzeughalter sind die am meisten verwendeten.</p>	 <p>← ≈ 4×D →</p>	<p>Ø 18-24 mm = 117,5 mm Ø 25-35 mm = 136,5 mm Ø 36-47 mm = 165,1 mm</p>	309	1				
					 <p>← ≈ 5×D →</p>	<p>Ø 9,5-12,5 mm = 60,3 mm Ø 13-17,5 mm = 63,5 mm Ø 18-24 mm = 168,3 mm Ø 25-35 mm = 187,3 mm Ø 36-47 mm = 209,6 mm Ø 48-65 mm = 231,8 mm</p>	311/313	2
					 <p>← ≈ 8×D →</p>	<p>Ø 9,5-12,5 mm = 111,1 mm Ø 13-17,5 mm = 114,3 mm Ø 18-24 mm = 269,9 mm Ø 25-35 mm = 288,9 mm</p>	315	
 <p>Schaft DIN 1835-B Zylindrischer Schaft mit Spannfläche</p> <p>Gerade genutet Bohrer steht still, Werkstück rotiert. Z.B. Drehmaschinen. Für Gussmaterialien ist die gerade genutete Version grundsätzlich besser, gleichgültig ob sich der Bohrer oder das Werkstück dreht.</p>	 <p>← ≈ 3×D →</p>	<p>Ø 9,5 - 12,5 mm = 31,8 mm Ø 13-17,5 mm = 34,9 mm Ø 18-24 mm = 66,7 mm Ø 25-35 mm = 85,7 mm Ø 36-47 mm = 120,7 mm Ø 48-65 mm = 130,2 mm</p>	317/319	3				
					 <p>← ≈ 8×D →</p>	<p>Ø 36-47 mm = 349,3 mm Ø 48-65 mm = 422,3 mm</p>	321	
					 <p>← ≈ 12×D →</p>	<p>Ø 9,5-11 mm = 222,0 mm Ø 11,5-12,5 mm = 222,3 mm Ø 13-17,5 mm = 295,0 mm Ø 18-24 mm = 457,0 mm Ø 25-35 mm = 511,0 mm Ø 36-47 mm = 558,8 mm Ø 48-65 mm = 625 mm</p>	323/325	
 <p>Morsekegel ISO 296 Typ BEK</p> <p>Spiral genutet Bohrer rotiert, Werkstück steht still. Z.B. Säulenbohrmaschinen, Radialbohrmaschinen. Spiralgenutete Werkzeughalter sind die am meisten verwendeten.</p>	 <p>← ≈ 4×D →</p>	<p>Ø 18-24 mm = 120,7 mm Ø 25-35 mm = 136,5 mm Ø 36-47 mm = 165,1 mm</p>	331	4				
					 <p>← ≈ 5×D →</p>	<p>Ø 9,5-12,5 mm = 60,3 mm Ø 13-17,5 mm = 63,5 mm Ø 18-24 mm = 171,5 mm Ø 25-35 mm = 187,3 mm Ø 36-47 mm = 209,5 mm Ø 48-65 mm = 231,8 mm</p>	333/335	
					 <p>← ≈ 8×D →</p>	<p>Ø 9,5-12,5 mm = 111,1 mm Ø 13-17,5 mm = 114,3 mm Ø 18-24 mm = 273,1 mm Ø 25-35 mm = 289,0 mm</p>	337	
 <p>Morsekegel ISO 296 Typ BEK</p> <p>Gerade genutet Bohrer steht still, Werkstück rotiert. Z.B. Drehmaschinen. Für Gussmaterialien ist die gerade genutete Version grundsätzlich besser, gleichgültig ob sich der Bohrer oder das Werkstück dreht.</p>	 <p>← ≈ 3×D →</p>	<p>Ø 9,5-12,5 mm = 31,8 mm Ø 13-17,5 mm = 35 mm Ø 18-24 mm = 69,8 mm Ø 25-35 mm = 85,7 mm Ø 36-47 mm = 120,6 mm Ø 48-65 mm = 130,1 mm Ø 64-114 mm = 171,5 mm</p>	339/341	5				
					 <p>← ≈ 8×D →</p>	<p>Ø 36-47 mm = 349,3 mm Ø 48-65 mm = 422,3 mm Ø 64-88 mm = 463,6 mm Ø 90-114 mm = 555,6 mm</p>	343/345	
					 <p>← ≈ 12×D →</p>	<p>Ø 36-47 mm = 558,8 mm Ø 48-65 mm = 625,0 mm Ø 64-88 mm = 660,0 mm Ø 90-114 mm = 685,0 mm</p>	347/349	
 <p>Morsekegel ISO 296 Typ BEK</p> <p>Sonderlösungen mit Pulverstahl Vollbohrern und Kernbohrer bis Ø 150 mm Ø 5.906"</p>			354/355	6				
					 <p>← ≈ 15×D →</p>	<p>Ø 36-47 mm = 787,4 mm Ø 48-65 mm = 879,0 mm Ø 64-88 mm = 889,0 mm Ø 90-114 mm = 939,0 mm</p>	351/353	
					 <p>← ≈ 15×D →</p>	<p>Ø 36-47 mm = 787,4 mm Ø 48-65 mm = 879,0 mm Ø 64-88 mm = 889,0 mm Ø 90-114 mm = 939,0 mm</p>	351/353	
 <p>Morsekegel ISO 296 Typ BEK</p> <p>Sonderlösungen mit Pulverstahl Vollbohrern und Kernbohrer bis Ø 150 mm Ø 5.906"</p>			354/355	7				
					 <p>← ≈ 15×D →</p>	<p>Ø 36-47 mm = 787,4 mm Ø 48-65 mm = 879,0 mm Ø 64-88 mm = 889,0 mm Ø 90-114 mm = 939,0 mm</p>	351/353	
 <p>Morse taper shank ISO 296 type BEK</p> <p>Special solutions with powder steel twist drill and annular cutter up to Ø 150 mm Ø 5.906"</p>			354/355	8				
					 <p>← ≈ 15×D →</p>	<p>Ø 36-47 mm = 787,4 mm Ø 48-65 mm = 879,0 mm Ø 64-88 mm = 889,0 mm Ø 90-114 mm = 939,0 mm</p>	351/353	

1 

2 

3 

4 

5 

6 

7 

8 

9 



PULVERSTAHL · POWDER STEEL

HARTMETALL · CARBIDE

Ø mm d1	Ø Zoll / Inch d1	22 2010		22 2510		22 3010		22 3510		22 4010		22 4510		22 5010		22 5510	
		Art.	€	Art.	€	Art.	€	Art.	€	Art.	€	Art.	€	Art.	€	Art.	€
• 18,00	• 0.7087	22 2010 0180	36,00	-	-	22 3010 0180	40,35	-	-	22 4010 0180	44,80	22 4510 0180	44,80	22 5010 0180	48,90	22 5510 0180	102,55
• 18,50	• 0.7283	22 2010 0185	36,00	-	-	22 3010 0185	40,35	-	-	22 4010 0185	44,80	22 4510 0185	44,80	22 5010 0185	48,90	22 5510 0185	102,55
• 19,00	• 0.7480	22 2010 0190	36,00	-	-	22 3010 0190	40,35	-	-	22 4010 0190	44,80	22 4510 0190	44,80	22 5010 0190	48,90	22 5510 0190	102,55
• 19,50	• 0.7677	22 2010 0195	36,00	-	-	22 3010 0195	40,35	-	-	22 4010 0195	44,80	22 4510 0195	44,80	22 5010 0195	48,90	22 5510 0195	102,55
• 20,00	• 0.7874	22 2010 0200	36,00	-	-	22 3010 0200	40,35	-	-	22 4010 0200	44,80	22 4510 0200	44,80	22 5010 0200	48,90	22 5510 0200	102,55
• 20,50	• 0.8071	22 2010 0205	36,00	-	-	22 3010 0205	40,35	-	-	22 4010 0205	44,80	22 4510 0205	44,80	22 5010 0205	48,90	22 5510 0205	118,55
• 21,00	• 0.8268	22 2010 0210	36,00	-	-	22 3010 0210	40,35	-	-	22 4010 0210	44,80	22 4510 0210	44,80	22 5010 0210	48,90	22 5510 0210	118,55
• 22,00	• 0.8661	22 2010 0220	36,00	-	-	22 3010 0220	40,35	-	-	22 4010 0220	44,80	22 4510 0220	44,80	22 5010 0220	48,90	22 5510 0220	118,55
• 23,00	• 0.9055	22 2010 0230	36,00	-	-	22 3010 0230	40,35	-	-	22 4010 0230	44,80	22 4510 0230	44,80	22 5010 0230	48,90	22 5510 0230	118,55
• 24,00	• 0.9449	22 2010 0240	36,00	-	-	22 3010 0240	40,35	-	-	22 4010 0240	44,80	22 4510 0240	44,80	22 5010 0240	48,90	22 5510 0240	118,55
• 25,00	• 0.9843	22 2010 0250	42,15	-	-	22 3010 0250	45,45	-	-	22 4010 0250	52,45	22 4510 0250	52,45	22 5010 0250	55,55	22 5510 0250	125,20
• 26,00	• 1.0236	22 2010 0260	42,15	-	-	22 3010 0260	45,45	-	-	22 4010 0260	52,45	22 4510 0260	52,45	22 5010 0260	55,55	22 5510 0260	125,20
• 26,50	• 1.0433	22 2010 0265	42,15	-	-	22 3010 0265	45,45	-	-	22 4010 0265	52,45	22 4510 0265	52,45	22 5010 0265	55,55	22 5510 0265	125,20
• 27,00	• 1.0630	22 2010 0270	42,15	-	-	22 3010 0270	45,45	-	-	22 4010 0270	52,45	22 4510 0270	52,45	22 5010 0270	55,55	22 5510 0270	125,20
• 28,00	• 1.1024	22 2010 0280	42,15	-	-	22 3010 0280	45,45	-	-	22 4010 0280	52,45	22 4510 0280	52,45	22 5010 0280	55,55	22 5510 0280	125,20
• 29,00	• 1.1417	22 2010 0290	42,15	-	-	22 3010 0290	45,45	-	-	22 4010 0290	52,45	22 4510 0290	52,45	22 5010 0290	55,55	22 5510 0290	125,20
• 30,00	• 1.1811	22 2010 0300	42,15	-	-	22 3010 0300	45,45	-	-	22 4010 0300	52,45	22 4510 0300	52,45	22 5010 0300	55,55	22 5510 0300	125,20
• 31,00	• 1.2205	22 2010 0310	42,15	-	-	22 3010 0310	45,45	-	-	22 4010 0310	52,45	22 4510 0310	52,45	22 5010 0310	55,55	22 5510 0310	125,20
• 32,00	• 1.2598	22 2010 0320	42,15	-	-	22 3010 0320	45,45	-	-	22 4010 0320	52,45	22 4510 0320	52,45	22 5010 0320	55,55	22 5510 0320	125,20
• 33,00	• 1.2992	22 2010 0330	42,15	-	-	22 3010 0330	45,45	-	-	22 4010 0330	52,45	22 4510 0330	52,45	22 5010 0330	55,55	22 5510 0330	132,90
• 34,00	• 1.3386	22 2010 0340	42,15	-	-	22 3010 0340	45,45	-	-	22 4010 0340	52,45	22 4510 0340	52,45	22 5010 0340	55,55	22 5510 0340	132,90
• 35,00	• 1.3780	22 2010 0350	42,15	-	-	22 3010 0350	45,45	-	-	22 4010 0350	52,45	22 4510 0350	52,45	22 5010 0350	55,55	22 5510 0350	132,90
• 36,00	• 1.4173	22 2010 0360	57,75	-	-	22 3010 0360	59,50	-	-	-	-	-	-	-	-	-	-
• 37,00	• 1.4567	22 2010 0370	57,75	-	-	22 3010 0370	59,50	-	-	-	-	-	-	-	-	-	-
• 38,00	• 1.4961	22 2010 0380	57,75	-	-	22 3010 0380	59,50	-	-	-	-	-	-	-	-	-	-
• 39,00	• 1.5354	22 2010 0390	57,75	-	-	22 3010 0390	59,50	-	-	-	-	-	-	-	-	-	-
• 40,00	• 1.5748	22 2010 0400	57,75	-	-	22 3010 0400	59,50	-	-	-	-	-	-	-	-	-	-
• 41,00	• 1.6142	22 2010 0410	57,75	-	-	22 3010 0410	59,50	-	-	-	-	-	-	-	-	-	-
• 42,00	• 1.6535	22 2010 0420	57,75	-	-	22 3010 0420	59,50	-	-	-	-	-	-	-	-	-	-
• 43,00	• 1.6929	22 2010 0430	57,75	-	-	22 3010 0430	59,50	-	-	-	-	-	-	-	-	-	-
• 44,00	• 1.7323	22 2010 0440	57,75	-	-	22 3010 0440	59,50	-	-	-	-	-	-	-	-	-	-
• 45,00	• 1.7717	22 2010 0450	57,75	-	-	22 3010 0450	59,50	-	-	-	-	-	-	-	-	-	-
• 46,00	• 1.8110	22 2010 0460	57,75	-	-	22 3010 0460	59,50	-	-	-	-	-	-	-	-	-	-
• 47,00	• 1.8504	22 2010 0470	57,75	-	-	22 3010 0470	59,50	-	-	-	-	-	-	-	-	-	-

Weitere Ø bis maximal Ø 65 mm | 2.5591" in 5xD siehe Seite 312
 Further Ø up to Ø 65 mm | 2.5591" in 5xD see page 312



DIN 1835-B
Zylindrischer Schaft
mit Spannfläche ·
Lateral fixation type
flange shank

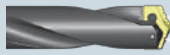

Spiral genutet ·
Helical flute

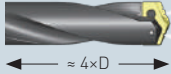
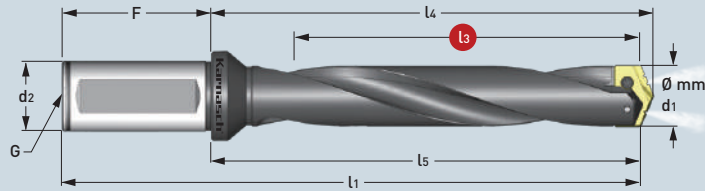

Mittel ·
Intermediate

Art.	€	l ₃		l ₅		l ₄		l ₁		d ₂		F		G	
		mm Zoll / Inch	mm Zoll / Inch	mm Zoll / Inch	mm Zoll / Inch	mm Zoll / Inch	mm Zoll / Inch	mm Zoll / Inch	mm Zoll / Inch	mm Zoll / Inch	mm Zoll / Inch	mm Zoll / Inch	mm Zoll / Inch	mm Zoll / Inch	mm Zoll / Inch
<ul style="list-style-type: none"> 22 1010 01175 0180 Ø 18,0-24,0 mm 0.7087-0.9449" MÖGLICH · POSSIBLE Ø 18,0-21,0 mm 0.7087-0.8268" OPTIMAL · OPTIMAL 22 1010 01175 0220 Ø 22,0-24,0 mm 0.8661-0.9449" OPTIMAL · OPTIMAL 	156,05	117,5 mm 4.6260"	154,8 mm 6.0945"	158,4 mm 6.2362"	210,8 mm 8.2992"	25,0 mm 0.9843"	56,0 mm 2.2047"					1/8"			
<ul style="list-style-type: none"> 22 1010 01365 0255 Ø 25,0-35,0 mm 0.9843-1.3780" MÖGLICH · POSSIBLE Ø 25,0-29,0 mm 0.9843-1.1417" OPTIMAL · OPTIMAL 22 1010 01365 0300 Ø 30,0-35,0 mm 1.1811-1.3780" OPTIMAL · OPTIMAL 	203,30	136,5 mm 5.3740"	179,4 mm 7.0630"	183,0 mm 7.2047"	239,4 mm 9.4252"	32,0 mm 1.2598"	60,0 mm 2.3622"					1/4"			
<ul style="list-style-type: none"> 22 1010 01651 0360 Ø 36,0-47,0 mm 1.4173-1.8504" MÖGLICH · POSSIBLE Ø 36,0-41,0 mm 1.4173-1.6142" OPTIMAL · OPTIMAL 22 1010 01651 0420 Ø 42,0-47,0 mm 1.6535-1.8504" OPTIMAL · OPTIMAL 	288,25	165,1 mm 6.5000"	217,5 mm 8.5630"	222,3 mm 8.7520"	287,5 mm 11.3189"	40,0 mm 1.5748"	70,0 mm 2.7559"					1/4"			

Halter werden **ohne** Einsätze, inklusive 2x TORX Befestigungsschrauben und 1x TORX Schlüssel geliefert.
 Holders are delivered **without** inserts including 2x TORX-screws and 1x TORX wrench.

Ersatz-Torxschrauben und Schlüssel mit Drehmomentangabe
 Spare Torx-screws and wrench with torque specification

Ø Diameter		TORX	€	max. Drehmoment / Torque (N/cm)	Schlüssel / Wrench	€
mm	Zoll / Inch					
9,5-11,0	0.3740-0.4331	22 9010 0095	3,50	84	22 9011 0084	9,90
11,5-12,5	0.4528-0.4921	22 9010 0115	3,50	84	22 9011 0175	9,90
13,0-17,5	0.5118-0.6890	22 9010 0130	3,50	175	22 9011 0305	10,90
18,0-24,0	0.7087-0.9449	22 9010 0180	3,50	305	22 9011 0690	11,70
25,0-35,0	0.9843-1.3780	22 9010 0250	3,60	690	22 9011 1370	12,70
36,0-65,0	1.4173-2.5591	22 9010 0360	3,65	1370	22 9011 1750	18,70
64,0-114,0	2.5197-4.4882	22 9010 0640	3,70	1750		

Schnittdaten
Cutting data



Film
Movie



1302-1311

309





DIN 1835-B
Zylindrischer Schaft
mit Spannfläche ·
Lateral fixation type
flange shank

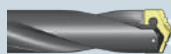

Spiral genutet ·
Helical flute

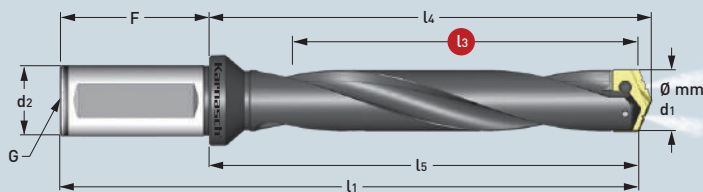

Mittel-Lang ·
Intermediate-Long

Art.	€	l3 Nutzlänge Max. drill depth	l5 Körperlänge Body-length	l4 Neue REF.- Länge REF.-length	l1 Gesamtlänge Overall length	d2 Schaft-Ø Shank-Ø	F Schaftlänge Shank length	G Gewinde Pipe tap
		mm Zoll / Inch	mm Zoll / Inch	mm Zoll / Inch	mm Zoll / Inch	mm Zoll / Inch	mm Zoll / Inch	
• 22 1010 00603 0095 Ø 9,5-11,0 mm 0.3740-0.4331" OPTIMAL · OPTIMAL	122,75	60,3 mm 2.3740"	89,7 mm 3.5315"	92,1 mm 3.6260"	139,7 mm 5.5000"	20,0 mm 0.7874"	50,0 mm 1.9685"	1/8"
• 22 1010 00603 0115 Ø 11,5-12,5 mm 0.4528-0.4921" OPTIMAL · OPTIMAL	122,75	60,3 mm 2.3740"	89,7 mm 3.5315"	92,1 mm 3.6260"	139,7 mm 5.5000"	20,0 mm 0.7874"	50,0 mm 1.9685"	1/8"
• 22 1010 00635 0130 Ø 13,0-17,5 mm 0.5118-0.6890" MÖGLICH · POSSIBLE Ø 13,0-15,0 mm 0.5118-0.5906" OPTIMAL · OPTIMAL	129,90	63,5 mm 2.5000"	92,1 mm 3.6260"	94,9 mm 3.7362"	142,1 mm 5.5945"	20,0 mm 0.7874"	50,0 mm 1.9685"	1/8"
• 22 1010 00635 0155 Ø 15,5-17,5 mm 0.6102-0.6890" OPTIMAL · OPTIMAL	129,90	63,5 mm 2.5000"	92,1 mm 3.6260"	94,9 mm 3.7362"	142,1 mm 5.5945"	20,0 mm 0.7874"	50,0 mm 1.9685"	1/8"
• 22 1010 01683 0180 Ø 18,0-24,0 mm 0.7087-0.9449" MÖGLICH · POSSIBLE Ø 18,0-21,0 mm 0.7087-0.8268" OPTIMAL · OPTIMAL	178,80	168,3 mm 6.6260"	205,6 mm 8.0945"	209,2 mm 8.2362"	261,6 mm 10.2992"	25,0 mm 0.9843"	56,0 mm 2.2047"	1/8"
• 22 1010 01683 0220 Ø 22,0-24,0 mm 0.8661-0.9449" OPTIMAL · OPTIMAL	178,80	168,3 mm 6.6260"	205,6 mm 8.0945"	209,2 mm 8.2362"	261,6 mm 10.2992"	25,0 mm 0.9843"	56,0 mm 2.2047"	1/8"
• 22 1010 01873 0250 Ø 25,0-35,0 mm 0.9843-1.3780" MÖGLICH · POSSIBLE Ø 25,0-29,0 mm 0.9843-1.1417" OPTIMAL · OPTIMAL	229,35	187,3 mm 7.3740"	230,2 mm 9.0630"	233,8 mm 9.2047"	290,2 mm 11.4252"	32,0 mm 1.2598"	60,0 mm 2.3622"	1/4"
• 22 1010 01873 0300 Ø 30,0-35,0 mm 1.1811-1.3780" OPTIMAL · OPTIMAL	229,35	187,3 mm 7.3740"	230,2 mm 9.0630"	233,8 mm 9.2047"	290,2 mm 11.4252"	32,0 mm 1.2598"	60,0 mm 2.3622"	1/4"
• 22 1010 02096 0360 Ø 36,0-47,0 mm 1.4173-1.8504" MÖGLICH · POSSIBLE Ø 36,0-41,0 mm 1.4173-1.6142" OPTIMAL · OPTIMAL	310,85	209,6 mm 8.2520"	261,9 mm 10.3110"	266,7 mm 10.5000"	331,9 mm 13.0669"	40,0 mm 1.5748"	70,0 mm 2.7559"	1/4"
• 22 1010 02096 0420 Ø 42,0-47,0 mm 1.6535-1.8504" OPTIMAL · OPTIMAL	310,85	209,6 mm 8.2520"	261,9 mm 10.3110"	266,7 mm 10.5000"	331,9 mm 13.0669"	40,0 mm 1.5748"	70,0 mm 2.7559"	1/4"

Fortsetzung Seite 313 · Continued page 313

Schnittdaten
Cutting data

Film
Movie

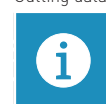

1302-1311





PULVERSTAHL · POWDER STEEL				HARTMETALL · CARBIDE					
Ø mm d1	Ø Zoll / Inch d1	22 2010 Pulverstahl 25 STEEL-TEC beschichtet Für Edelstahl, Stahl, Guss Powder steel 25 STEEL-TEC coated For stainless steel, steel, cast iron	22 2510 Pulverstahl 15 STEEL-TEC beschichtet Für legierte Stähle, Edelstahl, Stahl, Guss Powder steel 15 STEEL-TEC coated For alloy steel, stainless steel, steel, cast iron	22 3010 Pulverstahl 25 ALU-TEC beschichtet Für Alu, Messing, Kupfer Powder steel 25 ALU-TEC coated For alu, brass, copper	22 3510 Pulverstahl 15 ALU-TEC beschichtet Für Alu, Messing, Kupfer Powder steel 15 ALU-TEC coated For alloy steel, steel, cast iron	22 4010 Hartmetall 20/30 STEEL-TEC beschichtet Für Edelstahl, hochfester Stahl, gehärteter Stahl Carbide 20/30 STEEL-TEC coated For stainless steel, high strength alloys, hardened steel	22 4510 Hartmetall 20/30 STEEL-TEC beschichtet Für alle Gussarten Carbide 20/30 STEEL-TEC coated For all kinds of cast iron	22 5010 Hartmetall 20/30 ALU-TEC beschichtet Für Alu, Messing, Kupfer Carbide 20/30 ALU-TEC coated For alu, brass, copper	22 5510 Hartmetall 20/30 DIA-TEC beschichtet Für abrasive Materialien wie: GFK, CFK, Graphit Carbide 20/30 DIA-TEC coated For abrasive materials such as: fiberglass, carbon fiber, graphite
Art.	€	Art.	€	Art.	€	Art.	€	Art.	€
• 48,00	1.8898	22 2010 0480	82,65	-	-	22 3010 0480	82,65	-	-
• 49,00	1.9291	22 2010 0490	82,65	-	-	22 3010 0490	82,65	-	-
• 50,00	1.9685	22 2010 0500	82,65	-	-	22 3010 0500	82,65	-	-
• 51,00	2.0079	22 2010 0510	82,65	-	-	22 3010 0510	82,65	-	-
• 52,00	2.0472	22 2010 0520	82,65	-	-	22 3010 0520	82,65	-	-
• 53,00	2.0866	22 2010 0530	82,65	-	-	22 3010 0530	82,65	-	-
• 54,00	2.1260	22 2010 0540	82,65	-	-	22 3010 0540	82,65	-	-
• 55,00	2.1654	22 2010 0550	82,65	-	-	22 3010 0550	82,65	-	-
• 56,00	2.2047	22 2010 0560	82,65	-	-	22 3010 0560	82,65	-	-
• 57,00	2.2441	22 2010 0570	82,65	-	-	22 3010 0570	82,65	-	-
• 58,00	2.2835	22 2010 0580	82,65	-	-	22 3010 0580	82,65	-	-
• 59,00	2.3228	22 2010 0590	82,65	-	-	22 3010 0590	82,65	-	-
• 60,00	2.3622	22 2010 0600	82,65	-	-	22 3010 0600	82,65	-	-
• 61,00	2.4016	22 2010 0610	82,65	-	-	22 3010 0610	82,65	-	-
• 62,00	2.4409	22 2010 0620	82,65	-	-	22 3010 0620	82,65	-	-
• 63,00	2.4803	22 2010 0630	82,65	-	-	22 3010 0630	82,65	-	-
• 64,00	2.5197	22 2010 0640	82,65	-	-	22 3010 0640	82,65	-	-
• 65,00	2.5591	22 2010 0650	82,65	-	-	22 3010 0650	82,65	-	-



DIN 1835-B
Zylindrischer Schaft
mit Spannfläche ·
Lateral fixation type
flange shank

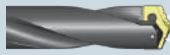

Spiral genutet ·
Helical flute

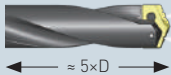
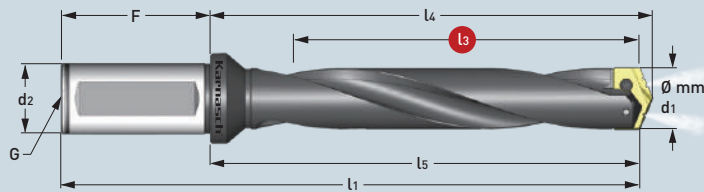

≈ 5×D
Mittel-Lang ·
Intermediate-Long

Art.	€	l3 Nutzlänge Max. drill depth	l5 Körperlänge Body-length	l4 Neue REF.- Länge REF.-length	l1 Gesamtlänge Overall length	d2 Schaft-Ø Shank-Ø	F Schaftlänge Shank length	G Gewinde Pipe tap
		mm Zoll / Inch	mm Zoll / Inch	mm Zoll / Inch	mm Zoll / Inch	mm Zoll / Inch	mm Zoll / Inch	
• 22 1010 02318 0480 Ø 48,0-65,0 mm 1.8898-2.5591" MÖGLICH · POSSIBLE Ø 48,0-55,0 mm 1.8898-2.1654" OPTIMAL · OPTIMAL	333,70	231,8 mm 9.1260"	281,0 mm 11.0630"	285,8 mm 11.2520"	351,0 mm 13.8189"	40 mm 1.5748"	70,0 mm 2.7559"	1/4"
• 22 1010 02318 0560 Ø 56,0-65,0 mm 2.2047-2.5591" OPTIMAL · OPTIMAL	333,70	231,8 mm 9.1260"	281,0 mm 11.0630"	285,8 mm 11.2520"	351,0 mm 13.8189"	40 mm 1.5748"	70,0 mm 2.7559"	1/4"

Halter werden **ohne** Einsätze, inklusive 2× TORX Befestigungsschrauben und 1× TORX Schlüssel geliefert.
 Holders are delivered **without** inserts including 2× TORX-screws and 1× TORX wrench.

Ersatz-Torxschrauben und Schlüssel mit Drehmomentangabe
 Spare Torx-screws and wrench with torque specification

Ø Diameter		TORX		max. Drehmoment / Torque (N/cm)	Schlüssel / Wrench	
mm	Zoll / Inch		€			€
9,5-11,0	0.3740-0.4331	22 9010 0095	3,50	84	22 9011 0084	9,90
11,5-12,5	0.4528-0.4921	22 9010 0115	3,50	84	22 9011 0175	9,90
13,0-17,5	0.5118-0.6890	22 9010 0130	3,50	175	22 9011 0305	10,90
18,0-24,0	0.7087-0.9449	22 9010 0180	3,50	305	22 9011 0690	11,70
25,0-35,0	0.9843-1.3780	22 9010 0250	3,60	690	22 9011 1370	12,70
36,0-65,0	1.4173-2.5591	22 9010 0360	3,65	1370	22 9011 1750	18,70
64,0-114,0	2.5197-4.4882	22 9010 0640	3,70	1750		

Schnittdaten
Cutting data



1302-1311

Film
Movie



313



PULVERSTAHL · POWDER STEEL

HARTMETALL · CARBIDE

		132°		144°		132°		144°		132°		Guss/Cast iron 132°	132°		132°		
Ø mm d1	Ø Zoll / Inch d1	22 2010 Pulverstahl 25 STEEL-TEC beschichtet Für Edelstahl, Stahl, Guss		22 2510 Pulverstahl 15 STEEL-TEC beschichtet Für legierte Stähle, Edelstahl, Stahl, Guss		22 3010 Pulverstahl 25 ALU-TEC beschichtet Für Alu, Messing, Kupfer		22 3510 Pulverstahl 15 ALU-TEC beschichtet Für Alu, Messing, Kupfer		22 4010 Hartmetall 20/30 STEEL-TEC beschichtet Für Edelstahl, hochfester Stahl, gehärteter Stahl		22 4510 Hartmetall 20/30 STEEL-TEC beschichtet Für alle Gussarten		22 5010 Hartmetall 20/30 ALU-TEC beschichtet Für Alu, Messing, Kupfer		22 5510 Hartmetall 20/30 DIA-TEC beschichtet Für abrasive Materialien wie: GFK, CFK, Graphit	
		Powder steel 25 STEEL-TEC coated For stainless steel, steel, cast iron		Powder steel 15 STEEL-TEC coated For alloy steel, stainless steel, steel, cast iron		Powder steel 25 ALU-TEC coated For alu, brass, copper		Powder steel 15 ALU-TEC coated For alloy steel, steel, cast iron		Carbide 20/30 STEEL-TEC coated For stainless steel, high strength alloys, hardened steel		Carbide 20/30 STEEL-TEC coated For all kinds of cast iron		Carbide 20/30 ALU-TEC coated For alu, brass, copper		Carbide 20/30 DIA-TEC coated For abrasive materials such as: fiberglass, carbon fiber, graphite	
		Art.	€	Art.	€	Art.	€	Art.	€	Art.	€	Art.	€	Art.	€	Art.	€
● 9,50	0.3740	22 2010 0095	24,85	-	-	22 3010 0095	26,05	-	-	22 4010 0095	29,30	22 4510 0095	29,30	22 5010 0095	30,45	22 5510 0095	66,40
○ 9,80	0.3858	-	-	-	-	-	-	-	-	-	-	-	-	-	-	-	-
● 10,00	0.3937	22 2010 0100	24,85	-	-	22 3010 0100	26,05	-	-	22 4010 0100	29,30	22 4510 0100	29,30	22 5010 0100	30,45	22 5510 0100	66,40
● 10,20	0.4016	22 2010 0102	24,85	-	-	22 3010 0102	26,05	-	-	22 4010 0102	29,30	22 4510 0102	29,30	22 5010 0102	30,45	22 5510 0102	66,40
● 10,50	0.4134	22 2010 0105	24,85	-	-	22 3010 0105	26,05	-	-	22 4010 0105	29,30	22 4510 0105	29,30	22 5010 0105	30,45	22 5510 0105	66,40
● 10,80	0.4252	22 2010 0108	24,85	-	-	22 3010 0108	26,05	-	-	22 4010 0108	29,30	22 4510 0108	29,30	22 5010 0108	30,45	22 5510 0108	66,40
● 11,00	0.4331	22 2010 0110	24,85	-	-	22 3010 0110	26,05	-	-	22 4010 0110	29,30	22 4510 0110	29,30	22 5010 0110	30,45	22 5510 0110	66,40
● 11,50	0.4528	22 2010 0115	24,85	-	-	22 3010 0115	26,05	-	-	22 4010 0115	29,30	22 4510 0115	29,30	22 5010 0115	30,45	22 5510 0115	66,40
● 12,00	0.4724	22 2010 0120	24,85	-	-	22 3010 0120	26,05	-	-	22 4010 0120	29,30	22 4510 0120	29,30	22 5010 0120	30,45	22 5510 0120	66,40
● 12,50	0.4921	22 2010 0125	24,85	-	-	22 3010 0125	26,05	-	-	22 4010 0125	29,30	22 4510 0125	29,30	22 5010 0125	30,45	22 5510 0125	66,40
● 13,00	0.5118	22 2010 0130	28,30	-	-	22 3010 0130	28,95	-	-	22 4010 0130	34,45	22 4510 0130	34,45	22 5010 0130	35,10	22 5510 0130	92,70
● 13,50	0.5315	22 2010 0135	28,30	-	-	22 3010 0135	28,95	-	-	22 4010 0135	34,45	22 4510 0135	34,45	22 5010 0135	35,10	22 5510 0135	92,70
● 14,00	0.5512	22 2010 0140	28,30	-	-	22 3010 0140	28,95	-	-	22 4010 0140	34,45	22 4510 0140	34,45	22 5010 0140	35,10	22 5510 0140	92,70
● 14,50	0.5709	22 2010 0145	28,30	-	-	22 3010 0145	28,95	-	-	22 4010 0145	34,45	22 4510 0145	34,45	22 5010 0145	35,10	22 5510 0145	92,70
● 15,00	0.5906	22 2010 0150	28,30	-	-	22 3010 0150	28,95	-	-	22 4010 0150	34,45	22 4510 0150	34,45	22 5010 0150	35,10	22 5510 0150	92,70
● 15,50	0.6102	22 2010 0155	28,30	-	-	22 3010 0155	28,95	-	-	22 4010 0155	34,45	22 4510 0155	34,45	22 5010 0155	35,10	22 5510 0155	92,70
● 16,00	0.6299	22 2010 0160	28,30	-	-	22 3010 0160	28,95	-	-	22 4010 0160	34,45	22 4510 0160	34,45	22 5010 0160	35,10	22 5510 0160	92,70
● 16,50	0.6496	22 2010 0165	28,30	-	-	22 3010 0165	28,95	-	-	22 4010 0165	34,45	22 4510 0165	34,45	22 5010 0165	35,10	22 5510 0165	92,70
● 17,00	0.6693	22 2010 0170	28,30	-	-	22 3010 0170	28,95	-	-	22 4010 0170	34,45	22 4510 0170	34,45	22 5010 0170	35,10	22 5510 0170	92,70
● 17,50	0.6890	22 2010 0175	28,30	-	-	22 3010 0175	28,95	-	-	22 4010 0175	34,45	22 4510 0175	34,45	22 5010 0175	35,10	22 5510 0175	92,70
● 18,00	0.7087	22 2010 0180	36,00	-	-	22 3010 0180	40,35	-	-	22 4010 0180	44,80	22 4510 0180	44,80	22 5010 0180	48,90	22 5510 0180	102,55
● 18,50	0.7283	22 2010 0185	36,00	-	-	22 3010 0185	40,35	-	-	22 4010 0185	44,80	22 4510 0185	44,80	22 5010 0185	48,90	22 5510 0185	102,55
● 19,00	0.7480	22 2010 0190	36,00	-	-	22 3010 0190	40,35	-	-	22 4010 0190	44,80	22 4510 0190	44,80	22 5010 0190	48,90	22 5510 0190	102,55
● 19,50	0.7677	22 2010 0195	36,00	-	-	22 3010 0195	40,35	-	-	22 4010 0195	44,80	22 4510 0195	44,80	22 5010 0195	48,90	22 5510 0195	102,55
● 20,00	0.7874	22 2010 0200	36,00	-	-	22 3010 0200	40,35	-	-	22 4010 0200	44,80	22 4510 0200	44,80	22 5010 0200	48,90	22 5510 0200	102,55
● 20,50	0.8071	22 2010 0205	36,00	-	-	22 3010 0205	40,35	-	-	22 4010 0205	44,80	22 4510 0205	44,80	22 5010 0205	48,90	22 5510 0205	118,55
● 21,00	0.8268	22 2010 0210	36,00	-	-	22 3010 0210	40,35	-	-	22 4010 0210	44,80	22 4510 0210	44,80	22 5010 0210	48,90	22 5510 0210	118,55
● 22,00	0.8661	22 2010 0220	36,00	-	-	22 3010 0220	40,35	-	-	22 4010 0220	44,80	22 4510 0220	44,80	22 5010 0220	48,90	22 5510 0220	118,55
● 23,00	0.9055	22 2010 0230	36,00	-	-	22 3010 0230	40,35	-	-	22 4010 0230	44,80	22 4510 0230	44,80	22 5010 0230	48,90	22 5510 0230	118,55
● 24,00	0.9449	22 2010 0240	36,00	-	-	22 3010 0240	40,35	-	-	22 4010 0240	44,80	22 4510 0240	44,80	22 5010 0240	48,90	22 5510 0240	118,55
● 25,00	0.9843	22 2010 0250	42,15	-	-	22 3010 0250	45,45	-	-	22 4010 0250	52,45	22 4510 0250	52,45	22 5010 0250	55,55	22 5510 0250	125,20
● 26,00	1.0236	22 2010 0260	42,15	-	-	22 3010 0260	45,45	-	-	22 4010 0260	52,45	22 4510 0260	52,45	22 5010 0260	55,55	22 5510 0260	125,20
● 26,50	1.0433	22 2010 0265	42,15	-	-	22 3010 0265	45,45	-	-	22 4010 0265	52,45	22 4510 0265	52,45	22 5010 0265	55,55	22 5510 0265	125,20
● 27,00	1.0630	22 2010 0270	42,15	-	-	22 3010 0270	45,45	-	-	22 4010 0270	52,45	22 4510 0270	52,45	22 5010 0270	55,55	22 5510 0270	125,20
● 28,00	1.1024	22 2010 0280	42,15	-	-	22 3010 0280	45,45	-	-	22 4010 0280	52,45	22 4510 0280	52,45	22 5010 0280	55,55	22 5510 0280	125,20
● 29,00	1.1417	22 2010 0290	42,15	-	-	22 3010 0290	45,45	-	-	22 4010 0290	52,45	22 4510 0290	52,45	22 5010 0290	55,55	22 5510 0290	125,20
● 30,00	1.1811	22 2010 0300	42,15	-	-	22 3010 0300	45,45	-	-	22 4010 0300	52,45	22 4510 0300	52,45	22 5010 0300	55,55	22 5510 0300	125,20
● 31,00	1.2205	22 2010 0310	42,15	-	-	22 3010 0310	45,45	-	-	22 4010 0310	52,45	22 4510 0310	52,45	22 5010 0310	55,55	22 5510 0310	125,20
● 32,00	1.2598	22 2010 0320	42,15	-	-	22 3010 0320	45,45	-	-	22 4010 0320	52,45	22 4510 0320	52,45	22 5010 0320	55,55	22 5510 0320	125,20
● 33,00	1.2992	22 2010 0330	42,15	-	-	22 3010 0330	45,45	-	-	22 4010 0330	52,45	22 4510 0330	52,45	22 5010 0330	55,55	22 5510 0330	132,90
● 34,00	1.3386	22 2010 0340	42,15	-	-	22 3010 0340	45,45	-	-	22 4010 0340	52,45	22 4510 0340	52,45	22 5010 0340	55,55	22 5510 0340	132,90
● 35,00	1.3780	22 2010 0350	42,15	-	-	22 3010 0350	45,45	-	-	22 4010 0350	52,45	22 4510 0350	52,45	22 5010 0350	55,55	22 5510 0350	132,90

Schnittdaten
Cutting data

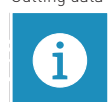

Film
Movie



1302-1311



DIN 1835-B
Zylindrischer Schaft
mit Spannfläche ·
Lateral fixation type
flange shank



Spiral genutet ·
Helical flute

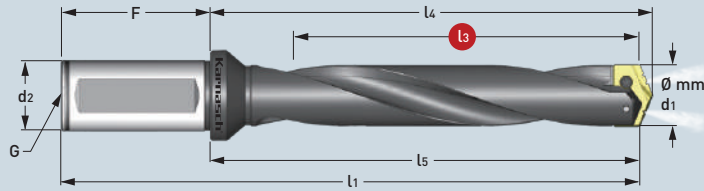

Lang · Long
≈ 8×D

Art.	€	l3 Nutzlänge Max. drill depth	l5 Körperlänge Body-length	l4 Neue REF.- Länge REF.-length	l1 Gesamtlänge Overall length	d2 Schaft-Ø Shank-Ø	F Schaftlänge Shank length	G Gewinde Pipe tap
		mm Zoll / Inch	mm Zoll / Inch	mm Zoll / Inch	mm Zoll / Inch	mm Zoll / Inch	mm Zoll / Inch	
• 22 1010 01111 0095 Ø 9,5-11,0 mm 0.3740-0.4331" OPTIMAL · OPTIMAL	146,55	111,1 mm 4.3740"	140,5 mm 5.5315"	142,9 mm 5.6260"	190,5 mm 7.5000"	20,0 mm 0.7874"	50,0 mm 1.9685"	1/8"
• 22 1010 01111 0115 Ø 11,5-12,5 mm 0.4528-0.4921" OPTIMAL · OPTIMAL	146,55	111,1 mm 4.3740"	140,5 mm 5.5315"	142,9 mm 5.6260"	190,5 mm 7.5000"	20,0 mm 0.7874"	50,0 mm 1.9685"	1/8"
• 22 1010 01143 0130 Ø 13,0-17,5 mm 0.5118-0.6890" MÖGLICH · POSSIBLE Ø 13,0-15,0 mm 0.5118-0.5906" OPTIMAL · OPTIMAL	156,15	114,3 mm 4.5000"	142,9 mm 5.6260"	145,7 mm 5.7362"	192,9 mm 7.5945"	20,0 mm 0.7874"	50,0 mm 1.9685"	1/8"
• 22 1010 01143 0155 Ø 15,5-17,5 mm 0.6102-0.6890" OPTIMAL · OPTIMAL	156,15	114,3 mm 4.5000"	142,9 mm 5.6260"	145,7 mm 5.7362"	192,9 mm 7.5945"	20,0 mm 0.7874"	50,0 mm 1.9685"	1/8"
• 22 1010 02699 0180 Ø 18,0-24,0 mm 0.7087-0.9449" MÖGLICH · POSSIBLE Ø 18,0-21,0 mm 0.7087-0.8268" OPTIMAL · OPTIMAL	224,35	269,9 mm 10.6260"	307,2 mm 12.0945"	310,8 mm 12.2362"	363,2 mm 14.2992"	25,0 mm 0.9843"	56,0 mm 2.2047"	1/8"
• 22 1010 02699 0220 Ø 22,0-24,0 mm 0.8661-0.9449" OPTIMAL · OPTIMAL	224,35	269,9 mm 10.6260"	307,2 mm 12.0945"	310,8 mm 12.2362"	363,2 mm 14.2992"	25,0 mm 0.9843"	56,0 mm 2.2047"	1/8"
• 22 1010 02889 0250 Ø 25,0-35,0 mm 0.9843-1.3780" MÖGLICH · POSSIBLE Ø 25,0-29,0 mm 0.9843-1.1417" OPTIMAL · OPTIMAL	274,80	288,9 mm 11.3740"	331,8 mm 13.0630"	335,4 mm 13.2047"	391,8 mm 15.4252"	32,0 mm 1.2598"	60,0 mm 2.3622"	1/4"
• 22 1010 02889 0300 Ø 30,0-35,0 mm 1.1811-1.3780" OPTIMAL · OPTIMAL	274,80	288,9 mm 11.3740"	331,8 mm 13.0630"	335,4 mm 13.2047"	391,8 mm 15.4252"	32,0 mm 1.2598"	60,0 mm 2.3622"	1/4"

Halter werden **ohne** Einsätze, inklusive 2x TORX Befestigungsschrauben und 1x TORX Schlüssel geliefert.
 Holders are delivered **without** inserts including 2x TORX-screws and 1x TORX wrench.

Ersatz-Torxschrauben und Schlüssel mit Drehmomentangabe
 Spare Torx-screws and wrench with torque specification

Ø Diameter		TORX		max. Drehmoment / Torque (N/cm)	Schlüssel / Wrench	
mm	Zoll / Inch		€			€
9,5-11,0	0.3740-0.4331	22 9010 0095	3,50	84		
11,5-12,5	0.4528-0.4921	22 9010 0115	3,50	84	22 9011 0084	9,90
13,0-17,5	0.5118-0.6890	22 9010 0130	3,50	175	22 9011 0175	9,90
18,0-24,0	0.7087-0.9449	22 9010 0180	3,50	305	22 9011 0305	10,90
25,0-35,0	0.9843-1.3780	22 9010 0250	3,60	690	22 9011 0690	11,70
36,0-65,0	1.4173-2.5591	22 9010 0360	3,65	1370	22 9011 1370	12,70
64,0-114,0	2.5197-4.4882	22 9010 0640	3,70	1750	22 9011 1750	18,70





DIN 1835-B
Zylindrischer Schaft
mit Spannfläche ·
Lateral fixation type
flange shank



Gerade genutet ·
Straight flute

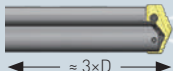
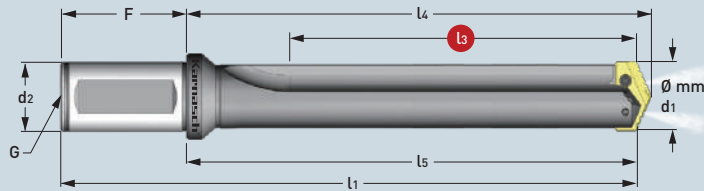

≈ 3×D
Kurz · Short

Art.	€	L3		L5		L4		L1		d2		F		G	
		mm Zoll / Inch	mm Zoll / Inch	mm Zoll / Inch	mm Zoll / Inch	mm Zoll / Inch	mm Zoll / Inch	mm Zoll / Inch	mm Zoll / Inch	mm Zoll / Inch	mm Zoll / Inch	mm Zoll / Inch	mm Zoll / Inch	mm Zoll / Inch	
• 22 1020 00318 0095 Ø 9,5-11,0 mm 0.3740-0.4331" OPTIMAL · OPTIMAL	111,95	31,8 mm 1.2520"	61,1 mm 2.4055"	63,5 mm 2.5000"	111,1 mm 4.3740"	20,0 mm 0.7874"	50,0 mm 1.9685"	1/8"							
• 22 1020 00318 0115 Ø 11,5-12,5 mm 0.4528-0.4921" OPTIMAL · OPTIMAL	111,95	31,8 mm 1.2520"	61,1 mm 2.4055"	63,5 mm 2.5000"	111,1 mm 4.3740"	20,0 mm 0.7874"	50,0 mm 1.9685"	1/8"							
• 22 1020 00349 0135 Ø 13,0-17,5 mm 0.5118-0.6890" MÖGLICH · POSSIBLE Ø 13,0-15,0 mm 0.5118-0.5906" OPTIMAL · OPTIMAL	122,50	34,9 mm 1.3740"	63,5 mm 2.5000"	66,3 mm 2.6102"	113,5 mm 4.4685"	20,0 mm 0.7874"	50,0 mm 1.9685"	1/8"							
• 22 1020 00349 0155 Ø 15,5-17,5 mm 0.6102-0.6890" OPTIMAL · OPTIMAL	122,50	34,9 mm 1.3740"	63,5 mm 2.5000"	66,3 mm 2.6102"	113,5 mm 4.4685"	20,0 mm 0.7874"	50,0 mm 1.9685"	1/8"							
• 22 1020 00667 0180 Ø 18,0-24,0 mm 0.7087-0.9449" MÖGLICH · POSSIBLE Ø 18,0-21,0 mm 0.7087-0.8268" OPTIMAL · OPTIMAL	136,90	66,7 mm 2.6260"	107,2 mm 4.2205"	110,7 mm 4.3583"	163,2 mm 6.4252"	25,0 mm 0.9842"	56,0 mm 2.2047"	1/8"							
• 22 1020 00667 0220 Ø 22,0-24,0 mm 0.8661-0.9449" OPTIMAL · OPTIMAL	136,90	66,7 mm 2.6260"	107,2 mm 4.2205"	110,7 mm 4.3583"	163,2 mm 6.4252"	25,0 mm 0.9842"	56,0 mm 2.2047"	1/8"							
• 22 1020 00857 0250 Ø 25,0-35,0 mm 0.9843-1.3780" MÖGLICH · POSSIBLE Ø 25,0-29,0 mm 0.9843-1.1417" OPTIMAL · OPTIMAL	166,25	85,7 mm 3.3740"	128,6 mm 5.0630"	132,2 mm 5.2047"	188,6 mm 7.4252"	32,0 mm 1.2598"	60,0 mm 2.3622"	1/4"							
• 22 1020 00857 0300 Ø 30,0-35,0 mm 1.1811-1.3780" OPTIMAL · OPTIMAL	166,25	85,7 mm 3.3740"	128,6 mm 5.0630"	132,2 mm 5.2047"	188,6 mm 7.4252"	32,0 mm 1.2598"	60,0 mm 2.3622"	1/4"							
• 22 1020 01207 0360 Ø 36,0-47,0 mm 1.4173-1.8504" MÖGLICH · POSSIBLE Ø 36,0-41,0 mm 1.4173-1.6142" OPTIMAL · OPTIMAL	224,05	120,7 mm 4.7520"	173,0 mm 6.8110"	177,8 mm 7.0000"	243,0 mm 9.5669"	40,0 mm 1.5748"	70,0 mm 2.7559"	1/4"							
• 22 1020 01207 0420 Ø 42,0-47,0 mm 1.6535-1.8504" OPTIMAL · OPTIMAL	224,05	120,7 mm 4.7520"	173,0 mm 6.8110"	177,8 mm 7.0000"	243,0 mm 9.5669"	40,0 mm 1.5748"	70,0 mm 2.7559"	1/4"							



Schnittdaten
Cutting data

Film
Movie



1302-1311



- 1 
- 2 
- 3 
- 4 
- 5 
- 6 
- 7 
- 8 
- 9 

PULVERSTAHL · POWDER STEEL

HARTMETALL · CARBIDE

Ø mm d1		Ø Zoll / Inch d1		22 2010		22 2510		22 3010		22 3510		22 4010		22 4510		22 5010		22 5510	
				Pulverstahl 25 STEEL-TEC beschichtet Für Edelstahl, Stahl, Guss Powder steel 25 STEEL-TEC coated For stainless steel, steel, cast iron		Pulverstahl 15 STEEL-TEC beschichtet Für legierte Stähle, Edelstahl, Stahl, Guss Powder steel 15 STEEL-TEC coated For alloy steel, stainless steel, steel, cast iron		Pulverstahl 25 ALU-TEC beschichtet Für Alu, Messing, Kupfer Powder steel 25 ALU-TEC coated For alu, brass, copper		Pulverstahl 15 ALU-TEC beschichtet Für Alu, Messing, Kupfer Powder steel 15 ALU-TEC coated For alloy steel, steel, cast iron		Hartmetall 20/30 STEEL-TEC beschichtet Für Edelstahl, hochfester Stahl, gehärteter Stahl Carbide 20/30 STEEL-TEC coated For stainless steel, high strength alloys, hardened steel		Guss/Cast iron Hartmetall 20/30 STEEL-TEC beschichtet Für alle Gussarten Carbide 20/30 STEEL-TEC coated For all kinds of cast iron		Hartmetall 20/30 ALU-TEC beschichtet Für Alu, Messing, Kupfer Carbide 20/30 ALU-TEC coated For alu, brass, copper		Hartmetall 20/30 DIA-TEC beschichtet Für abrasive Materialien wie: GFK, CFK, Graphit Carbide 20/30 DIA-TEC coated For abrasive materials such as: fiberglass, carbon fiber, graphite	
Art.	€	Art.	€	Art.	€	Art.	€	Art.	€	Art.	€	Art.	€	Art.	€	Art.	€	Art.	€
• 48,00	1.8898	22 2010 0480	82,65	-	-	22 3010 0480	82,65	-	-	-	-	-	-	-	-	-	-	-	-
• 49,00	1.9291	22 2010 0490	82,65	-	-	22 3010 0490	82,65	-	-	-	-	-	-	-	-	-	-	-	-
• 50,00	1.9685	22 2010 0500	82,65	-	-	22 3010 0500	82,65	-	-	-	-	-	-	-	-	-	-	-	-
• 51,00	2.0079	22 2010 0510	82,65	-	-	22 3010 0510	82,65	-	-	-	-	-	-	-	-	-	-	-	-
• 52,00	2.0472	22 2010 0520	82,65	-	-	22 3010 0520	82,65	-	-	-	-	-	-	-	-	-	-	-	-
• 53,00	2.0866	22 2010 0530	82,65	-	-	22 3010 0530	82,65	-	-	-	-	-	-	-	-	-	-	-	-
• 54,00	2.1260	22 2010 0540	82,65	-	-	22 3010 0540	82,65	-	-	-	-	-	-	-	-	-	-	-	-
• 55,00	2.1654	22 2010 0550	82,65	-	-	22 3010 0550	82,65	-	-	-	-	-	-	-	-	-	-	-	-
• 56,00	2.2047	22 2010 0560	82,65	-	-	22 3010 0560	82,65	-	-	-	-	-	-	-	-	-	-	-	-
• 57,00	2.2441	22 2010 0570	82,65	-	-	22 3010 0570	82,65	-	-	-	-	-	-	-	-	-	-	-	-
• 58,00	2.2835	22 2010 0580	82,65	-	-	22 3010 0580	82,65	-	-	-	-	-	-	-	-	-	-	-	-
• 59,00	2.3228	22 2010 0590	82,65	-	-	22 3010 0590	82,65	-	-	-	-	-	-	-	-	-	-	-	-
• 60,00	2.3622	22 2010 0600	82,65	-	-	22 3010 0600	82,65	-	-	-	-	-	-	-	-	-	-	-	-
• 61,00	2.4016	22 2010 0610	82,65	-	-	22 3010 0610	82,65	-	-	-	-	-	-	-	-	-	-	-	-
• 62,00	2.4409	22 2010 0620	82,65	-	-	22 3010 0620	82,65	-	-	-	-	-	-	-	-	-	-	-	-
• 63,00	2.4803	22 2010 0630	82,65	-	-	22 3010 0630	82,65	-	-	-	-	-	-	-	-	-	-	-	-
• 64,00	2.5197	22 2010 0640	82,65	-	-	22 3010 0640	82,65	-	-	-	-	-	-	-	-	-	-	-	-
• 65,00	2.5591	22 2010 0650	82,65	-	-	22 3010 0650	82,65	-	-	-	-	-	-	-	-	-	-	-	-



DIN 1835-B
Zylindrischer Schaft
mit Spannfläche ·
Lateral fixation type
flange shank



Gerade genutet ·
Straight flute

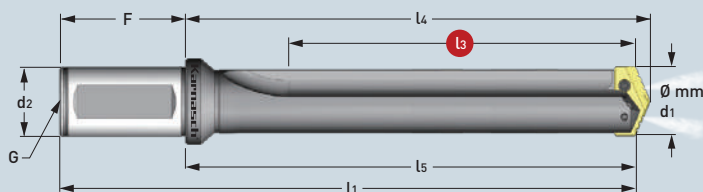

≈ 3×D
Kurz · Short

	l₃	l₅	l₄	l₁	d₂	F	G
	Nutzlänge Max. drill depth	Körperlänge Body-length	Neue REF.- Länge REF.-length	Gesamtlänge Overall length	Schaft-Ø Shank-Ø	Schaftlänge Shank length	Gewinde Pipe tap
Art.	€	mm Zoll / Inch	mm Zoll / Inch	mm Zoll / Inch	mm Zoll / Inch	mm Zoll / Inch	
• 22 1020 01302 0480 Ø 48,0-65,0 mm 1.8898-2.5591" MÖGLICH · POSSIBLE Ø 48,0-55,0 mm 1.8898-2.1654" OPTIMAL · OPTIMAL	238,60	130,2 mm 5.1260"	179,4 mm 7.0630"	184,2 mm 7.2520"	249,4 mm 9.8189"	40,0 mm 1.5748"	70,0 mm 2.7559"
• 22 1020 01302 0560 Ø 56,0-65,0 mm 2.2047-2.5591" OPTIMAL · OPTIMAL	238,60	130,2 mm 5.1260"	179,4 mm 7.0630"	184,2 mm 7.2520"	249,4 mm 9.8189"	40,0 mm 1.5748"	70,0 mm 2.7559"

Halter werden **ohne** Einsätze, inklusive 2× TORX Befestigungsschrauben und 1× TORX Schlüssel geliefert.
 Holders are delivered **without** inserts including 2× TORX-screws and 1× TORX wrench.

Ersatz-Torxschrauben und Schlüssel mit Drehmomentangabe
 Spare Torx-screws and wrench with torque specification

Ø Diameter		TORX		max. Drehmoment / Torque (N/cm)	Schlüssel / Wrench	
mm	Zoll / Inch		€			€
9,5-11,0	0.3740-0.4331	22 9010 0095	3,50	84	22 9011 0084	9,90
11,5-12,5	0.4528-0.4921	22 9010 0115	3,50	84	22 9011 0175	9,90
13,0-17,5	0.5118-0.6890	22 9010 0130	3,50	175	22 9011 0305	10,90
18,0-24,0	0.7087-0.9449	22 9010 0180	3,50	305	22 9011 0690	11,70
25,0-35,0	0.9843-1.3780	22 9010 0250	3,60	690	22 9011 1370	12,70
36,0-65,0	1.4173-2.5591	22 9010 0360	3,65	1370	22 9011 1750	18,70
64,0-114,0	2.5197-4.4882	22 9010 0640	3,70	1750		

Schnittdaten
Cutting data



1302-1311

Film
Movie



319





PULVERSTAHL · POWDER STEEL

HARTMETALL · CARBIDE

Ø mm d1	Ø Zoll / Inch d1	22 2010		22 2510		22 3010		22 3510		22 4010		22 4510		22 5010		22 5510	
		Art.	€	Art.	€	Art.	€	Art.	€	Art.	€	Art.	€	Art.	€	Art.	€
• 36,00	1.4173	22 2010 0360	57,75	-	-	22 3010 0360	59,50	-	-	-	-	-	-	-	-	-	-
• 37,00	1.4567	22 2010 0370	57,75	-	-	22 3010 0370	59,50	-	-	-	-	-	-	-	-	-	-
• 38,00	1.4961	22 2010 0380	57,75	-	-	22 3010 0380	59,50	-	-	-	-	-	-	-	-	-	-
• 39,00	1.5354	22 2010 0390	57,75	-	-	22 3010 0390	59,50	-	-	-	-	-	-	-	-	-	-
• 40,00	1.5748	22 2010 0400	57,75	-	-	22 3010 0400	59,50	-	-	-	-	-	-	-	-	-	-
• 41,00	1.6142	22 2010 0410	57,75	-	-	22 3010 0410	59,50	-	-	-	-	-	-	-	-	-	-
• 42,00	1.6535	22 2010 0420	57,75	-	-	22 3010 0420	59,50	-	-	-	-	-	-	-	-	-	-
• 43,00	1.6929	22 2010 0430	57,75	-	-	22 3010 0430	59,50	-	-	-	-	-	-	-	-	-	-
• 44,00	1.7323	22 2010 0440	57,75	-	-	22 3010 0440	59,50	-	-	-	-	-	-	-	-	-	-
• 45,00	1.7717	22 2010 0450	57,75	-	-	22 3010 0450	59,50	-	-	-	-	-	-	-	-	-	-
• 46,00	1.8110	22 2010 0460	57,75	-	-	22 3010 0460	59,50	-	-	-	-	-	-	-	-	-	-
• 47,00	1.8504	22 2010 0470	57,75	-	-	22 3010 0470	59,50	-	-	-	-	-	-	-	-	-	-
• 48,00	1.8898	22 2010 0480	82,65	-	-	22 3010 0480	82,65	-	-	-	-	-	-	-	-	-	-
• 49,00	1.9291	22 2010 0490	82,65	-	-	22 3010 0490	82,65	-	-	-	-	-	-	-	-	-	-
• 50,00	1.9685	22 2010 0500	82,65	-	-	22 3010 0500	82,65	-	-	-	-	-	-	-	-	-	-
• 51,00	2.0079	22 2010 0510	82,65	-	-	22 3010 0510	82,65	-	-	-	-	-	-	-	-	-	-
• 52,00	2.0472	22 2010 0520	82,65	-	-	22 3010 0520	82,65	-	-	-	-	-	-	-	-	-	-
• 53,00	2.0866	22 2010 0530	82,65	-	-	22 3010 0530	82,65	-	-	-	-	-	-	-	-	-	-
• 54,00	2.1260	22 2010 0540	82,65	-	-	22 3010 0540	82,65	-	-	-	-	-	-	-	-	-	-
• 55,00	2.1654	22 2010 0550	82,65	-	-	22 3010 0550	82,65	-	-	-	-	-	-	-	-	-	-
• 56,00	2.2047	22 2010 0560	82,65	-	-	22 3010 0560	82,65	-	-	-	-	-	-	-	-	-	-
• 57,00	2.2441	22 2010 0570	82,65	-	-	22 3010 0570	82,65	-	-	-	-	-	-	-	-	-	-
• 58,00	2.2835	22 2010 0580	82,65	-	-	22 3010 0580	82,65	-	-	-	-	-	-	-	-	-	-
• 59,00	2.3228	22 2010 0590	82,65	-	-	22 3010 0590	82,65	-	-	-	-	-	-	-	-	-	-
• 60,00	2.3622	22 2010 0600	82,65	-	-	22 3010 0600	82,65	-	-	-	-	-	-	-	-	-	-
• 61,00	2.4016	22 2010 0610	82,65	-	-	22 3010 0610	82,65	-	-	-	-	-	-	-	-	-	-
• 62,00	2.4409	22 2010 0620	82,65	-	-	22 3010 0620	82,65	-	-	-	-	-	-	-	-	-	-
• 63,00	2.4803	22 2010 0630	82,65	-	-	22 3010 0630	82,65	-	-	-	-	-	-	-	-	-	-
• 64,00	2.5197	22 2010 0640	82,65	-	-	22 3010 0640	82,65	-	-	-	-	-	-	-	-	-	-
• 65,00	2.5591	22 2010 0650	82,65	-	-	22 3010 0650	82,65	-	-	-	-	-	-	-	-	-	-



DIN 1835-B
Zylindrischer Schaft
mit Spannfläche ·
Lateral fixation type
flange shank



Gerade genutet ·
Straight flute

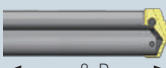
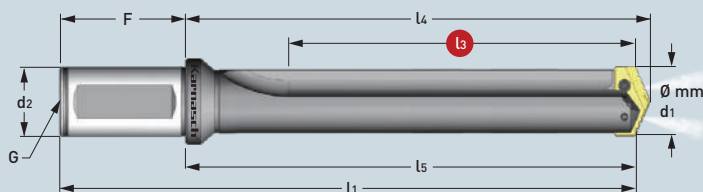

Lang · Long

Art.	€	l₃ Nutzlänge Max. drill depth	l₅ Körperlänge Body-length	l₄ Neue REF.- Länge REF.-length	l₁ Gesamtlänge Overall length	d₂ Schaft-Ø Shank-Ø	F Schaftlänge Shank length	G Gewinde Pipe tap
		mm Zoll / Inch	mm Zoll / Inch	mm Zoll / Inch	mm Zoll / Inch	mm Zoll / Inch	mm Zoll / Inch	
<ul style="list-style-type: none"> 22 1020 03493 0360 Ø 36,0-47,0 mm 1.4173-1.8504" MÖGLICH · POSSIBLE Ø 36,0-41,0 mm 1.4173-1.6142" OPTIMAL · OPTIMAL 22 1020 03493 0420 Ø 42,0-47,0 mm 1.6535-1.8504" OPTIMAL · OPTIMAL 	424,05	349,3 mm 13.7520"	401,6 mm 15.8110"	406,4 mm 16.0000"	471,6 mm 18.5669"	40,0 mm 1.5748"	70,0 mm 2.7559"	1/4"
<ul style="list-style-type: none"> 22 1020 04223 0480 Ø 48,0-65,0 mm 1.8898-2.5591" MÖGLICH · POSSIBLE Ø 48,0-55,0 mm 1.8898-2.1654" OPTIMAL · OPTIMAL 	480,10	422,3 mm 16.6260"	471,5 mm 18.5630"	476,3 mm 18.7520"	541,5 mm 21.3189"	40,0 mm 1.5748"	70,0 mm 2.7559"	1/4"
<ul style="list-style-type: none"> 22 1020 04223 0560 Ø 56,0-65,0 mm 2.2047-2.5591" OPTIMAL · OPTIMAL 	480,10	422,3 mm 16.6260"	471,5 mm 18.5630"	476,3 mm 18.7520"	541,5 mm 21.3189"	40,0 mm 1.5748"	70,0 mm 2.7559"	1/4"

Halter werden **ohne** Einsätze, inklusive 2x TORX Befestigungsschrauben und 1x TORX Schlüssel geliefert.
 Holders are delivered **without** inserts including 2x TORX-screws and 1x TORX wrench.

Ersatz-Torxschrauben und Schlüssel mit Drehmomentangabe
 Spare Torx-screws and wrench with torque specification

Ø Diameter		TORX	€	max. Drehmoment / Torque (N/cm)	Schlüssel / Wrench		€
mm	Zoll / Inch						
9,5-11,0	0.3740-0.4331	22 9010 0095	3,50	84			
11,5-12,5	0.4528-0.4921	22 9010 0115	3,50	84	22 9011 0084		9,90
13,0-17,5	0.5118-0.6890	22 9010 0130	3,50	175	22 9011 0175		9,90
18,0-24,0	0.7087-0.9449	22 9010 0180	3,50	305	22 9011 0305		10,90
25,0-35,0	0.9843-1.3780	22 9010 0250	3,60	690	22 9011 0690		11,70
36,0-65,0	1.4173-2.5591	22 9010 0360	3,65	1370	22 9011 1370		12,70
64,0-114,0	2.5197-4.4882	22 9010 0640	3,70	1750	22 9011 1750		18,70

Schnittdaten
Cutting data



Film
Movie



1302-1311



321



PULVERSTAHL · POWDER STEEL

HARTMETALL · CARBIDE

Ø mm d1	Ø Zoll / Inch d1	PULVERSTAHL · POWDER STEEL				HARTMETALL · CARBIDE												
		Art.	€	Art.	€	Art.	€	Art.	€									
132°		22 2010 Pulverstahl 25 STEEL-TEC beschichtet Für Edelstahl, Stahl, Guss Powder steel 25 STEEL-TEC coated For stainless steel, steel, cast iron		22 2510 Pulverstahl 15 STEEL-TEC beschichtet Für legierte Stähle, Edelstahl, Stahl, Guss Powder steel 15 STEEL-TEC coated For alloy steel, stainless steel, steel, cast iron		22 3010 Pulverstahl 25 ALU-TEC beschichtet Für Alu, Messing, Kupfer Powder steel 25 ALU-TEC coated For alu, brass, copper		22 3510 Pulverstahl 15 ALU-TEC beschichtet Für Alu, Messing, Kupfer Powder steel 15 ALU-TEC coated For alloy steel, steel, cast iron		22 4010 Hartmetall 20/30 STEEL-TEC beschichtet Für Edelstahl, hochfester Stahl, gehärteter Stahl Carbide 20/30 STEEL-TEC coated For stainless steel, high strength alloys, hardened steel		22 4510 Hartmetall 20/30 STEEL-TEC beschichtet Für alle Gussarten Carbide 20/30 STEEL-TEC coated For all kinds of cast iron		22 5010 Hartmetall 20/30 ALU-TEC beschichtet Für Alu, Messing, Kupfer Carbide 20/30 ALU-TEC coated For alu, brass, copper		22 5510 Hartmetall 20/30 DIA-TEC beschichtet Für abrasive Materialien wie: GFK, CFK, Graphit Carbide 20/30 DIA-TEC coated For abrasive materials such as: fiberglass, carbon fiber, graphite		
		• 9,50	0.3740	22 2010 0095	24,85	-	-	22 3010 0095	26,05	-	-	22 4010 0095	29,30	22 4510 0095	29,30	22 5010 0095	30,45	22 5510 0095
○ 9,80	0.3858	-	-	-	-	-	-	-	-	-	-	-	-	-	-	-	-	-
• 10,00	0.3937	22 2010 0100	24,85	-	-	22 3010 0100	26,05	-	-	22 4010 0100	29,30	22 4510 0100	29,30	22 5010 0100	30,45	22 5510 0100	66,40	
• 10,20	0.4016	22 2010 0102	24,85	-	-	22 3010 0102	26,05	-	-	22 4010 0102	29,30	22 4510 0102	29,30	22 5010 0102	30,45	22 5510 0102	66,40	
• 10,50	0.4134	22 2010 0105	24,85	-	-	22 3010 0105	26,05	-	-	22 4010 0105	29,30	22 4510 0105	29,30	22 5010 0105	30,45	22 5510 0105	66,40	
• 10,80	0.4252	22 2010 0108	24,85	-	-	22 3010 0108	26,05	-	-	22 4010 0108	29,30	22 4510 0108	29,30	22 5010 0108	30,45	22 5510 0108	66,40	
• 11,00	0.4331	22 2010 0110	24,85	-	-	22 3010 0110	26,05	-	-	22 4010 0110	29,30	22 4510 0110	29,30	22 5010 0110	30,45	22 5510 0110	66,40	
• 11,50	0.4528	22 2010 0115	24,85	-	-	22 3010 0115	26,05	-	-	22 4010 0115	29,30	22 4510 0115	29,30	22 5010 0115	30,45	22 5510 0115	66,40	
• 12,00	0.4724	22 2010 0120	24,85	-	-	22 3010 0120	26,05	-	-	22 4010 0120	29,30	22 4510 0120	29,30	22 5010 0120	30,45	22 5510 0120	66,40	
• 12,50	0.4921	22 2010 0125	24,85	-	-	22 3010 0125	26,05	-	-	22 4010 0125	29,30	22 4510 0125	29,30	22 5010 0125	30,45	22 5510 0125	66,40	
• 13,00	0.5118	22 2010 0130	28,30	-	-	22 3010 0130	28,95	-	-	22 4010 0130	34,45	22 4510 0130	34,45	22 5010 0130	35,10	22 5510 0130	92,70	
• 13,50	0.5315	22 2010 0135	28,30	-	-	22 3010 0135	28,95	-	-	22 4010 0135	34,45	22 4510 0135	34,45	22 5010 0135	35,10	22 5510 0135	92,70	
• 14,00	0.5512	22 2010 0140	28,30	-	-	22 3010 0140	28,95	-	-	22 4010 0140	34,45	22 4510 0140	34,45	22 5010 0140	35,10	22 5510 0140	92,70	
• 14,50	0.5709	22 2010 0145	28,30	-	-	22 3010 0145	28,95	-	-	22 4010 0145	34,45	22 4510 0145	34,45	22 5010 0145	35,10	22 5510 0145	92,70	
• 15,00	0.5906	22 2010 0150	28,30	-	-	22 3010 0150	28,95	-	-	22 4010 0150	34,45	22 4510 0150	34,45	22 5010 0150	35,10	22 5510 0150	92,70	
• 15,50	0.6102	22 2010 0155	28,30	-	-	22 3010 0155	28,95	-	-	22 4010 0155	34,45	22 4510 0155	34,45	22 5010 0155	35,10	22 5510 0155	92,70	
• 16,00	0.6299	22 2010 0160	28,30	-	-	22 3010 0160	28,95	-	-	22 4010 0160	34,45	22 4510 0160	34,45	22 5010 0160	35,10	22 5510 0160	92,70	
• 16,50	0.6496	22 2010 0165	28,30	-	-	22 3010 0165	28,95	-	-	22 4010 0165	34,45	22 4510 0165	34,45	22 5010 0165	35,10	22 5510 0165	92,70	
• 17,00	0.6693	22 2010 0170	28,30	-	-	22 3010 0170	28,95	-	-	22 4010 0170	34,45	22 4510 0170	34,45	22 5010 0170	35,10	22 5510 0170	92,70	
• 17,50	0.6890	22 2010 0175	28,30	-	-	22 3010 0175	28,95	-	-	22 4010 0175	34,45	22 4510 0175	34,45	22 5010 0175	35,10	22 5510 0175	92,70	
• 18,00	0.7087	22 2010 0180	36,00	-	-	22 3010 0180	40,35	-	-	22 4010 0180	44,80	22 4510 0180	44,80	22 5010 0180	48,90	22 5510 0180	102,55	
• 18,50	0.7283	22 2010 0185	36,00	-	-	22 3010 0185	40,35	-	-	22 4010 0185	44,80	22 4510 0185	44,80	22 5010 0185	48,90	22 5510 0185	102,55	
• 19,00	0.7480	22 2010 0190	36,00	-	-	22 3010 0190	40,35	-	-	22 4010 0190	44,80	22 4510 0190	44,80	22 5010 0190	48,90	22 5510 0190	102,55	
• 19,50	0.7677	22 2010 0195	36,00	-	-	22 3010 0195	40,35	-	-	22 4010 0195	44,80	22 4510 0195	44,80	22 5010 0195	48,90	22 5510 0195	102,55	
• 20,00	0.7874	22 2010 0200	36,00	-	-	22 3010 0200	40,35	-	-	22 4010 0200	44,80	22 4510 0200	44,80	22 5010 0200	48,90	22 5510 0200	102,55	
• 20,50	0.8071	22 2010 0205	36,00	-	-	22 3010 0205	40,35	-	-	22 4010 0205	44,80	22 4510 0205	44,80	22 5010 0205	48,90	22 5510 0205	118,55	
• 21,00	0.8268	22 2010 0210	36,00	-	-	22 3010 0210	40,35	-	-	22 4010 0210	44,80	22 4510 0210	44,80	22 5010 0210	48,90	22 5510 0210	118,55	
• 22,00	0.8661	22 2010 0220	36,00	-	-	22 3010 0220	40,35	-	-	22 4010 0220	44,80	22 4510 0220	44,80	22 5010 0220	48,90	22 5510 0220	118,55	
• 23,00	0.9055	22 2010 0230	36,00	-	-	22 3010 0230	40,35	-	-	22 4010 0230	44,80	22 4510 0230	44,80	22 5010 0230	48,90	22 5510 0230	118,55	
• 24,00	0.9449	22 2010 0240	36,00	-	-	22 3010 0240	40,35	-	-	22 4010 0240	44,80	22 4510 0240	44,80	22 5010 0240	48,90	22 5510 0240	118,55	
• 25,00	0.9843	22 2010 0250	42,15	-	-	22 3010 0250	45,45	-	-	22 4010 0250	52,45	22 4510 0250	52,45	22 5010 0250	55,55	22 5510 0250	125,20	
• 26,00	1.0236	22 2010 0260	42,15	-	-	22 3010 0260	45,45	-	-	22 4010 0260	52,45	22 4510 0260	52,45	22 5010 0260	55,55	22 5510 0260	125,20	
• 26,50	1.0433	22 2010 0265	42,15	-	-	22 3010 0265	45,45	-	-	22 4010 0265	52,45	22 4510 0265	52,45	22 5010 0265	55,55	22 5510 0265	125,20	
• 27,00	1.0630	22 2010 0270	42,15	-	-	22 3010 0270	45,45	-	-	22 4010 0270	52,45	22 4510 0270	52,45	22 5010 0270	55,55	22 5510 0270	125,20	
• 28,00	1.1024	22 2010 0280	42,15	-	-	22 3010 0280	45,45	-	-	22 4010 0280	52,45	22 4510 0280	52,45	22 5010 0280	55,55	22 5510 0280	125,20	
• 29,00	1.1417	22 2010 0290	42,15	-	-	22 3010 0290	45,45	-	-	22 4010 0290	52,45	22 4510 0290	52,45	22 5010 0290	55,55	22 5510 0290	125,20	
• 30,00	1.1811	22 2010 0300	42,15	-	-	22 3010 0300	45,45	-	-	22 4010 0300	52,45	22 4510 0300	52,45	22 5010 0300	55,55	22 5510 0300	125,20	
• 31,00	1.2205	22 2010 0310	42,15	-	-	22 3010 0310	45,45	-	-	22 4010 0310	52,45	22 4510 0310	52,45	22 5010 0310	55,55	22 5510 0310	125,20	
• 32,00	1.2598	22 2010 0320	42,15	-	-	22 3010 0320	45,45	-	-	22 4010 0320	52,45	22 4510 0320	52,45	22 5010 0320	55,55	22 5510 0320	125,20	
• 33,00	1.2992	22 2010 0330	42,15	-	-	22 3010 0330	45,45	-	-	22 4010 0330	52,45	22 4510 0330	52,45	22 5010 0330	55,55	22 5510 0330	132,90	
• 34,00	1.3386	22 2010 0340	42,15	-	-	22 3010 0340	45,45	-	-	22 4010 0340	52,45	22 4510 0340	52,45	22 5010 0340	55,55	22 5510 0340	132,90	
• 35,00	1.3780	22 2010 0350	42,15	-	-	22 3010 0350	45,45	-	-	22 4010 0350	52,45	22 4510 0350	52,45	22 5010 0350	55,55	22 5510 0350	132,90	
• 36,00	1.4173	22 2010 0360	57,75	-	-	22 3010 0360	59,50	-	-	-	-	-	-	-	-	-	-	
• 37,00	1.4567	22 2010 0370	57,75	-	-	22 3010 0370	59,50	-	-	-	-	-	-	-	-	-	-	
• 38,00	1.4961	22 2010 0380	57,75	-	-	22 3010 0380	59,50	-	-	-	-	-	-	-	-	-	-	
• 39,00	1.5354	22 2010 0390	57,75	-	-	22 3010 0390	59,50	-	-	-	-	-	-	-	-	-	-	
• 40,00	1.5748	22 2010 0400	57,75	-	-	22 3010 0400	59,50	-	-	-	-	-	-	-	-	-	-	
• 41,00	1.6142	22 2010 0410	57,75	-	-	22 3010 0410	59,50	-	-	-	-	-	-	-	-	-	-	
• 42,00	1.6535	22 2010 0420	57,75	-	-	22 3010 0420	59,50	-	-	-	-	-	-	-	-	-	-	
• 43,00	1.6929	22 2010 0430	57,75	-	-	22 3010 0430	59,50	-	-	-	-	-	-	-	-	-	-	
• 44,00	1.7323	22 2010 0440	57,75	-	-	22 3010 0440	59,50	-	-	-	-	-	-	-	-	-	-	
• 45,00	1.7717	22 2010 0450	57,75	-	-	22 3010 0450	59,50	-	-	-	-	-	-	-	-	-	-	
• 46,00	1.8110	22 2010 0460	57,75	-	-	22 3010 0460	59,50	-	-	-	-	-	-	-	-	-	-	
• 47,00	1.8504	22 2010 0470	57,75	-	-	22 3010 0470	59,50	-	-	-	-	-	-	-	-	-	-	

Fortsetzung Seite 324 · Continued page 324



DIN 1835-B
Zylindrischer Schaft
mit Spannfläche ·
Lateral fixation type
flange shank



Gerade genutet ·
Straight flute

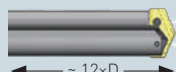
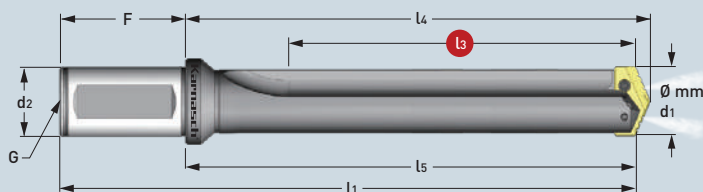

Überlang · Overlength

Art.	€	l₃ Nutzlänge Max. drill depth	l₅ Körperlänge Body-length	l₄ Neue REF.- Länge REF.-length	l₁ Gesamtlänge Overall length	d₂ Schaft-Ø Shank-Ø	F Schaftlänge Shank length	G Gewinde Pipe tap
		mm Zoll / Inch	mm Zoll / Inch	mm Zoll / Inch	mm Zoll / Inch	mm Zoll / Inch	mm Zoll / Inch	
• 22 1020 02220 0095 Ø 9,5-11,0 mm 0.3740-0.4331" OPTIMAL · OPTIMAL	196,40	222,0 mm 8.7401"	251,7 mm 9.9094"	254,1 mm 10.0039"	301,7 mm 11.8780"	20,0 mm 0.7874"	50,0 mm 1.9685"	1/8"
• 22 1020 02223 0115 Ø 11,5-12,5 mm 0.4528-0.4921" OPTIMAL · OPTIMAL	196,40	222,3 mm 8.7519"	251,7 mm 9.9094"	254,1 mm 10.0039"	301,7 mm 11.8780"	20,0 mm 0.7874"	50,0 mm 1.9685"	1/8"
• 22 1020 02950 0130 Ø 13,0-17,5 mm 0.5118-0.6890" MÖGLICH · POSSIBLE Ø 13,0-15,0 mm 0.5118-0.5906" OPTIMAL · OPTIMAL	245,40	295,0 mm 11.6142"	323,9 mm 12.7520"	326,7 mm 12.8622"	373,9 mm 14.7205"	20,0 mm 0.7874"	50,0 mm 1.9685"	1/8"
• 22 1020 02950 0155 Ø 15,5-17,5 mm 0.6102-0.6890" OPTIMAL · OPTIMAL	245,40	295,0 mm 11.6142"	323,9 mm 12.7520"	326,7 mm 12.8622"	373,9 mm 14.7205"	20,0 mm 0.7874"	50,0 mm 1.9685"	1/8"
• 22 1020 04570 0180 Ø 18,0-24,0 mm 0.7087-0.9449" MÖGLICH · POSSIBLE Ø 18,0-21,0 mm 0.7087-0.8268" OPTIMAL · OPTIMAL	337,50	457,0 mm 17.9921"	494,5 mm 19.4685"	498,1 mm 19.6102"	550,5 mm 21.6732"	25,0 mm 0.9842"	56,0 mm 2.2047"	1/8"
• 22 1020 04570 0220 Ø 22,0-24,0 mm 0.8661-0.9449" OPTIMAL · OPTIMAL	337,50	457,0 mm 17.9921"	494,5 mm 19.4685"	498,1 mm 19.6102"	550,5 mm 21.6732"	25,0 mm 0.9842"	56,0 mm 2.2047"	1/8"
• 22 1020 05110 0250 Ø 25,0-35,0 mm 0.9843-1.3780" MÖGLICH · POSSIBLE Ø 25,0-29,0 mm 0.9843-1.1417" OPTIMAL · OPTIMAL	406,80	511,0 mm 20.1181"	554,1 mm 21.8150"	557,7 mm 21.9567"	614,1 mm 24.1772"	32,0 mm 1.2598"	60,0 mm 2.3622"	1/4"
• 22 1020 05110 0300 Ø 30,0-35,0 mm 1.1811-1.3780" OPTIMAL · OPTIMAL	406,80	511,0 mm 20.1181"	554,1 mm 21.8150"	557,7 mm 21.9567"	614,1 mm 24.1772"	32,0 mm 1.2598"	60,0 mm 2.3622"	1/4"
• 22 1020 05588 0360 Ø 36,0-47,0 mm 1.4173-1.8504" MÖGLICH · POSSIBLE Ø 36,0-41,0 mm 1.4173-1.6142" OPTIMAL · OPTIMAL	595,05	558,8 mm 22.0000"	611,1 mm 24.0591"	615,9 mm 24.2480"	681,1 mm 26.8150"	40,0 mm 1.5748"	70,0 mm 2.7559"	1/4"
• 22 1020 05588 0420 Ø 42,0-47,0 mm 1.6535-1.8504" OPTIMAL · OPTIMAL	595,05	558,8 mm 22.0000"	611,1 mm 24.0591"	615,9 mm 24.2480"	681,1 mm 26.8150"	40,0 mm 1.5748"	70,0 mm 2.7559"	1/4"

Fortsetzung Seite 325 · Continued page 325

Schnittdaten
Cutting data

Film
Movie



1302-1311



323



Index

- 1 
- 2 
- 3 
- 4 
- 5 
- 6 
- 7 
- 8 
- 9 

PULVERSTAHL · POWDER STEEL

HARTMETALL · CARBIDE

Ø mm d1		Ø Zoll / Inch d1		22 2010		22 2510		22 3010		22 3510		22 4010		22 4510		22 5010		22 5510	
				Pulverstahl 25 STEEL-TEC beschichtet		Pulverstahl 15 STEEL-TEC beschichtet		Pulverstahl 25 ALU-TEC beschichtet		Pulverstahl 15 ALU-TEC beschichtet		Hartmetall 20/30 STEEL-TEC beschichtet		Hartmetall 20/30 STEEL-TEC beschichtet		Hartmetall 20/30 ALU-TEC beschichtet		Hartmetall 20/30 DIA-TEC beschichtet	
				Für Edelstahl, Stahl, Guss		Für legierte Stähle, Edelstahl, Stahl, Guss		Für Alu, Messing, Kupfer		Für Alu, Messing, Kupfer		Für Edelstahl, hochfester Stahl, gehärteter Stahl		Für alle Gussarten		Für Alu, Messing, Kupfer		Für abrasive Materialien wie: GFK, CFK, Graphit	
				Powder steel 25 STEEL-TEC coated		Powder steel 15 STEEL-TEC coated		Powder steel 25 ALU-TEC coated		Powder steel 15 ALU-TEC coated		Carbide 20/30 STEEL-TEC coated		Carbide 20/30 STEEL-TEC coated		Carbide 20/30 ALU-TEC coated		Carbide 20/30 DIA-TEC coated	
				For stainless steel, steel, cast iron		For alloy steel, stainless steel, steel, cast iron		For alu, brass, copper		For alloy steel, steel, cast iron		For stainless steel, high strength alloys, hardened steel		For all kinds of cast iron		For alu, brass, copper		For abrasive materials such as: fiberglass, carbon fiber, graphite	
Art.		€		Art.		€		Art.		€		Art.		€		Art.		€	
• 48,00	1.8898	22 2010 0480	82,65	-	-	22 3010 0480	82,65	-	-	-	-	-	-	-	-	-	-	-	-
• 49,00	1.9291	22 2010 0490	82,65	-	-	22 3010 0490	82,65	-	-	-	-	-	-	-	-	-	-	-	-
• 50,00	1.9685	22 2010 0500	82,65	-	-	22 3010 0500	82,65	-	-	-	-	-	-	-	-	-	-	-	-
• 51,00	2.0079	22 2010 0510	82,65	-	-	22 3010 0510	82,65	-	-	-	-	-	-	-	-	-	-	-	-
• 52,00	2.0472	22 2010 0520	82,65	-	-	22 3010 0520	82,65	-	-	-	-	-	-	-	-	-	-	-	-
• 53,00	2.0866	22 2010 0530	82,65	-	-	22 3010 0530	82,65	-	-	-	-	-	-	-	-	-	-	-	-
• 54,00	2.1260	22 2010 0540	82,65	-	-	22 3010 0540	82,65	-	-	-	-	-	-	-	-	-	-	-	-
• 55,00	2.1654	22 2010 0550	82,65	-	-	22 3010 0550	82,65	-	-	-	-	-	-	-	-	-	-	-	-
• 56,00	2.2047	22 2010 0560	82,65	-	-	22 3010 0560	82,65	-	-	-	-	-	-	-	-	-	-	-	-
• 57,00	2.2441	22 2010 0570	82,65	-	-	22 3010 0570	82,65	-	-	-	-	-	-	-	-	-	-	-	-
• 58,00	2.2835	22 2010 0580	82,65	-	-	22 3010 0580	82,65	-	-	-	-	-	-	-	-	-	-	-	-
• 59,00	2.3228	22 2010 0590	82,65	-	-	22 3010 0590	82,65	-	-	-	-	-	-	-	-	-	-	-	-
• 60,00	2.3622	22 2010 0600	82,65	-	-	22 3010 0600	82,65	-	-	-	-	-	-	-	-	-	-	-	-
• 61,00	2.4016	22 2010 0610	82,65	-	-	22 3010 0610	82,65	-	-	-	-	-	-	-	-	-	-	-	-
• 62,00	2.4409	22 2010 0620	82,65	-	-	22 3010 0620	82,65	-	-	-	-	-	-	-	-	-	-	-	-
• 63,00	2.4803	22 2010 0630	82,65	-	-	22 3010 0630	82,65	-	-	-	-	-	-	-	-	-	-	-	-
• 64,00	2.5197	22 2010 0640	82,65	-	-	22 3010 0640	82,65	-	-	-	-	-	-	-	-	-	-	-	-
• 65,00	2.5591	22 2010 0650	82,65	-	-	22 3010 0650	82,65	-	-	-	-	-	-	-	-	-	-	-	-



DIN 1835-B
Zylindrischer Schaft
mit Spannfläche ·
Lateral fixation type
flange shank



Gerade genutet ·
Straight flute

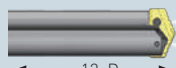
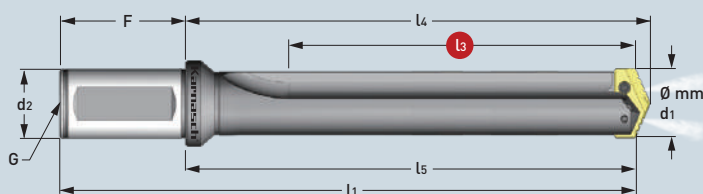

Überlang · Overlength

Art.	€	l₃ Nutzlänge Max. drill depth	l₅ Körperlänge Body-length	l₄ Neue REF.- Länge REF.-length	l₁ Gesamtlänge Overall length	d₂ Schaft-Ø Shank-Ø	F Schaftlänge Shank length	G Gewinde Pipe tap
		mm Zoll / Inch	mm Zoll / Inch	mm Zoll / Inch	mm Zoll / Inch	mm Zoll / Inch	mm Zoll / Inch	
<ul style="list-style-type: none"> 22 1020 06250 0480 Ø 48,0-65,0 mm 1.8898-2.5591" MÖGLICH · POSSIBLE Ø 48,0-55,0 mm 1.8898-2.1654" OPTIMAL · OPTIMAL 	728,80	625,0 mm 24.6063"	674,7 mm 26.5630"	679,5 mm 26.7520"	744,7 mm 29.3189"	40,0 mm 1.5748"	70,0 mm 2.7559"	1/4"
<ul style="list-style-type: none"> 22 1020 06250 0560 Ø 56,0-65,0 mm 2.2047-2.5591" OPTIMAL · OPTIMAL 	728,80	625,0 mm 24.6063"	674,7 mm 26.5630"	679,5 mm 26.7520"	744,7 mm 29.3189"	40,0 mm 1.5748"	70,0 mm 2.7559"	1/4"

Halter werden **ohne** Einsätze, inklusive 2x TORX Befestigungsschrauben und 1x TORX Schlüssel geliefert.
 Holders are delivered **without** inserts including 2x TORX-screws and 1x TORX wrench.

Ersatz-Torxschrauben und Schlüssel mit Drehmomentangabe
 Spare Torx-screws and wrench with torque specification

Ø Diameter		TORX		max. Drehmoment / Torque (N/cm)	Schlüssel / Wrench	
mm	Zoll / Inch		€			€
9,5-11,0	0.3740-0.4331	22 9010 0095	3,50	84	22 9011 0084	9,90
11,5-12,5	0.4528-0.4921	22 9010 0115	3,50	84	22 9011 0175	9,90
13,0-17,5	0.5118-0.6890	22 9010 0130	3,50	175	22 9011 0305	10,90
18,0-24,0	0.7087-0.9449	22 9010 0180	3,50	305	22 9011 0690	11,70
25,0-35,0	0.9843-1.3780	22 9010 0250	3,60	690	22 9011 1370	12,70
36,0-65,0	1.4173-2.5591	22 9010 0360	3,65	1370	22 9011 1750	18,70
64,0-114,0	2.5197-4.4882	22 9010 0640	3,70	1750		

Schnittdaten
Cutting data



1302-1311

Film
Movie



325

- 1 
- 2 
- 3 
- 4 
- 5 
- 6 
- 7 
- 8 
- 9 

PULVERSTAHL · POWDER STEEL

HARTMETALL · CARBIDE

Ø mm d ₁	Ø Zoll / Inch d ₁	132°				144°				132°				132°				132° 			
		Art.	€	Art.	€	Art.	€	Art.	€	Art.	€	Art.	€	Art.	€	Art.	€	Art.	€		
<div style="display: flex; justify-content: space-between;"> <div style="width: 20%;"> <p>22 2010 Pulverstahl 25 STEEL-TEC beschichtet Für Edelstahl, Stahl, Guss</p> <p>Powder steel 25 STEEL-TEC coated For stainless steel, steel, cast iron</p> </div> <div style="width: 20%;"> <p>22 2510 Pulverstahl 15 STEEL-TEC beschichtet Für legierte Stähle, Edelstahl, Stahl, Guss</p> <p>Powder steel 15 STEEL-TEC coated For alloy steel, stainless steel, steel, cast iron</p> </div> <div style="width: 20%;"> <p>22 3010 Pulverstahl 25 ALU-TEC beschichtet Für Alu, Messing, Kupfer</p> <p>Powder steel 25 ALU-TEC coated For alu, brass, copper</p> </div> <div style="width: 20%;"> <p>22 3510 Pulverstahl 15 ALU-TEC beschichtet Für Alu, Messing, Kupfer</p> <p>Powder steel 15 ALU-TEC coated For alloy steel, steel, cast iron</p> </div> <div style="width: 20%;"> <p>22 4010 Hartmetall 20/30 STEEL-TEC beschichtet Für Edelstahl, hochfester Stahl, gehärteter Stahl</p> <p>Carbide 20/30 STEEL-TEC coated For stainless steel, high strength alloys, hardened steel</p> </div> <div style="width: 20%;"> <p>22 4510 Hartmetall 20/30 STEEL-TEC beschichtet Für alle Gussarten</p> <p>Carbide 20/30 STEEL-TEC coated For all kinds of cast iron</p> </div> <div style="width: 20%;"> <p>22 5010 Hartmetall 20/30 ALU-TEC beschichtet Für Alu, Messing, Kupfer</p> <p>Carbide 20/30 ALU-TEC coated For alu, brass, copper</p> </div> <div style="width: 20%;"> <p>22 5510 Hartmetall 20/30 DIA-TEC beschichtet Für abrasive Materialien wie: GFK, CFK, Graphit</p> <p>Carbide 20/30 DIA-TEC coated For abrasive materials such as: fiberglass, carbon fiber, graphite</p> </div> </div>																					

Fortsetzung Seite 328 · Continued page 328



DIN 1835-B
Zylindrischer Schaft mit Spannfläche ·
Lateral fixation type
flange shank



Gerade genutet ·
Straight flute

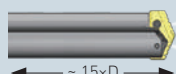
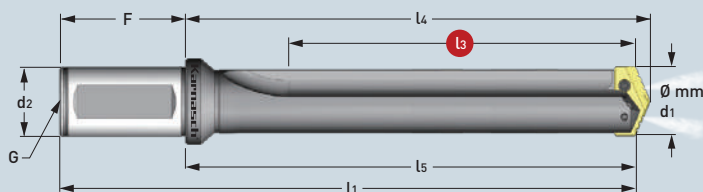

~ 15×D
Ultralang · Ultralength

	L3	L5	L4	L1	d2	F	G
	Nutzlänge	Körperlänge	Neue REF.- Länge	Gesamtlänge	Schaft-Ø	Schaftlänge	Gewinde
	Max. drill depth	Body-length	REF.-length	Overall length	Shank-Ø	Shank length	Pipe tap

Art.	€	mm Zoll / Inch	mm Zoll / Inch	mm Zoll / Inch	mm Zoll / Inch	mm Zoll / Inch	mm Zoll / Inch	mm Zoll / Inch
• 22 1020 02900 0095 Ø 9,5-11,0 mm 0.3740-0.4331" OPTIMAL · OPTIMAL	245,65	290,0 mm 11.4173"	319,9 mm 12.5945"	322,3 mm 12.6890"	369,9 mm 14.5630"	20,0 mm 0.7874"	50,0 mm 1.9685"	1/8"
• 22 1020 02905 0115 Ø 11,5-12,5 mm 0.4528-0.4921" OPTIMAL · OPTIMAL	245,65	290,0 mm 11.4173"	319,9 mm 12.5945"	322,3 mm 12.6890"	369,9 mm 14.5630"	20,0 mm 0.7874"	50,0 mm 1.9685"	1/8"
• 22 1020 03870 0130 Ø 13,0-17,5 mm 0.5118-0.6890" MÖGLICH · POSSIBLE Ø 13,0-15,0 mm 0.5118-0.5906" OPTIMAL · OPTIMAL	306,55	387,0 mm 15.2362"	416,0 mm 16.3780"	418,8 mm 16.4882"	466,0 mm 18.3465"	20,0 mm 0.7874"	50,0 mm 1.9685"	1/8"
• 22 1020 03870 0155 Ø 15,5-17,5 mm 0.6102-0.6890" OPTIMAL · OPTIMAL	306,55	387,0 mm 15.2362"	416,0 mm 16.3780"	418,8 mm 16.4882"	466,0 mm 18.3465"	20,0 mm 0.7874"	50,0 mm 1.9685"	1/8"
• 22 1020 05690 0180 Ø 18,0-24,0 mm 0.7087-0.9449" MÖGLICH · POSSIBLE Ø 18,0-21,0 mm 0.7087-0.8268" OPTIMAL · OPTIMAL	436,75	569,0 mm 22.4016"	602,5 mm 23.7205"	606,1 mm 23.8622"	658,5 mm 25.9252"	25,0 mm 0.9842"	56,0 mm 2.2047"	1/8"
• 22 1020 05690 0220 Ø 22,0-24,0 mm 0.8661-0.9449" OPTIMAL · OPTIMAL	436,75	569,0 mm 22.4016"	602,5 mm 23.7205"	606,1 mm 23.8622"	658,5 mm 25.9252"	25,0 mm 0.9842"	56,0 mm 2.2047"	1/8"
• 22 1020 06920 0250 Ø 25,0-35,0 mm 0.9843-1.3780" MÖGLICH · POSSIBLE Ø 25,0-29,0 mm 0.9843-1.1417" OPTIMAL · OPTIMAL	551,05	692,0 mm 27.2441"	735,1 mm 28.9409"	738,7 mm 29.0827"	795,1 mm 31.3031"	32,0 mm 1.2598"	60,0 mm 2.3622"	1/4"
• 22 1020 06920 0300 Ø 30,0-35,0 mm 1.1811-1.3780" OPTIMAL · OPTIMAL	551,05	692,0 mm 27.2441"	735,1 mm 28.9409"	738,7 mm 29.0827"	795,1 mm 31.3031"	32,0 mm 1.2598"	60,0 mm 2.3622"	1/4"
• 22 1020 07874 0360 Ø 36,0-47,0 mm 1.4173-1.8504" MÖGLICH · POSSIBLE Ø 36,0-41,0 mm 1.4173-1.6142" OPTIMAL · OPTIMAL	797,35	787,4 mm 31.0000"	839,7 mm 33.0591"	844,5 mm 33.2480"	909,7 mm 35.8150"	40,0 mm 1.5748"	70,0 mm 2.7559"	1/4"
• 22 1020 07874 0420 Ø 42,0-47,0 mm 1.6535-1.8504" OPTIMAL · OPTIMAL	797,35	787,4 mm 31.0000"	839,7 mm 33.0591"	844,5 mm 33.2480"	909,7 mm 35.8150"	40,0 mm 1.5748"	70,0 mm 2.7559"	1/4"

Schnittdaten
Cutting data

Film
Movie



1302-1311



- 1 
- 2 
- 3 
- 4 
- 5 
- 6 
- 7 
- 8 
- 9 

PULVERSTAHL · POWDER STEEL

HARTMETALL · CARBIDE

Ø mm d1		Ø Zoll / Inch d1		22 2010		22 2510		22 3010		22 3510		22 4010		22 4510		22 5010		22 5510	
				Pulverstahl 25 STEEL-TEC beschichtet		Pulverstahl 15 STEEL-TEC beschichtet		Pulverstahl 25 ALU-TEC beschichtet		Pulverstahl 15 ALU-TEC beschichtet		Hartmetall 20/30 STEEL-TEC beschichtet		Hartmetall 20/30 STEEL-TEC beschichtet		Hartmetall 20/30 ALU-TEC beschichtet		Hartmetall 20/30 DIA-TEC beschichtet	
				Für Edelstahl, Stahl, Guss		Für legierte Stähle, Edelstahl, Stahl, Guss		Für Alu, Messing, Kupfer		Für Alu, Messing, Kupfer		Für Edelstahl, hochfester Stahl, gehärteter Stahl		Für alle Gussarten		Für Alu, Messing, Kupfer		Für abrasive Materialien wie: GFK, CFK, Graphit	
				Powder steel 25 STEEL-TEC coated		Powder steel 15 STEEL-TEC coated		Powder steel 25 ALU-TEC coated		Powder steel 15 ALU-TEC coated		Carbide 20/30 STEEL-TEC coated		Carbide 20/30 STEEL-TEC coated		Carbide 20/30 ALU-TEC coated		Carbide 20/30 DIA-TEC coated	
				For stainless steel, steel, cast iron		For alloy steel, stainless steel, steel, cast iron		For alu, brass, copper		For alloy steel, steel, cast iron		For stainless steel, high strength alloys, hardened steel		For all kinds of cast iron		For alu, brass, copper		For abrasive materials such as: fiberglass, carbon fiber, graphite	
Art.		€		Art.		€		Art.		€		Art.		€		Art.		€	
• 48,00	1.8898	22 2010 0480	82,65	-	-	22 3010 0480	82,65	-	-	-	-	-	-	-	-	-	-	-	-
• 49,00	1.9291	22 2010 0490	82,65	-	-	22 3010 0490	82,65	-	-	-	-	-	-	-	-	-	-	-	-
• 50,00	1.9685	22 2010 0500	82,65	-	-	22 3010 0500	82,65	-	-	-	-	-	-	-	-	-	-	-	-
• 51,00	2.0079	22 2010 0510	82,65	-	-	22 3010 0510	82,65	-	-	-	-	-	-	-	-	-	-	-	-
• 52,00	2.0472	22 2010 0520	82,65	-	-	22 3010 0520	82,65	-	-	-	-	-	-	-	-	-	-	-	-
• 53,00	2.0866	22 2010 0530	82,65	-	-	22 3010 0530	82,65	-	-	-	-	-	-	-	-	-	-	-	-
• 54,00	2.1260	22 2010 0540	82,65	-	-	22 3010 0540	82,65	-	-	-	-	-	-	-	-	-	-	-	-
• 55,00	2.1654	22 2010 0550	82,65	-	-	22 3010 0550	82,65	-	-	-	-	-	-	-	-	-	-	-	-
• 56,00	2.2047	22 2010 0560	82,65	-	-	22 3010 0560	82,65	-	-	-	-	-	-	-	-	-	-	-	-
• 57,00	2.2441	22 2010 0570	82,65	-	-	22 3010 0570	82,65	-	-	-	-	-	-	-	-	-	-	-	-
• 58,00	2.2835	22 2010 0580	82,65	-	-	22 3010 0580	82,65	-	-	-	-	-	-	-	-	-	-	-	-
• 59,00	2.3228	22 2010 0590	82,65	-	-	22 3010 0590	82,65	-	-	-	-	-	-	-	-	-	-	-	-
• 60,00	2.3622	22 2010 0600	82,65	-	-	22 3010 0600	82,65	-	-	-	-	-	-	-	-	-	-	-	-
• 61,00	2.4016	22 2010 0610	82,65	-	-	22 3010 0610	82,65	-	-	-	-	-	-	-	-	-	-	-	-
• 62,00	2.4409	22 2010 0620	82,65	-	-	22 3010 0620	82,65	-	-	-	-	-	-	-	-	-	-	-	-
• 63,00	2.4803	22 2010 0630	82,65	-	-	22 3010 0630	82,65	-	-	-	-	-	-	-	-	-	-	-	-
• 64,00	2.5197	22 2010 0640	82,65	-	-	22 3010 0640	82,65	-	-	-	-	-	-	-	-	-	-	-	-
• 65,00	2.5591	22 2010 0650	82,65	-	-	22 3010 0650	82,65	-	-	-	-	-	-	-	-	-	-	-	-



DIN 1835-B
Zylindrischer Schaft
mit Spannfläche ·
Lateral fixation type
flange shank



Gerade genutet ·
Straight flute

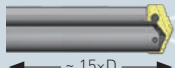
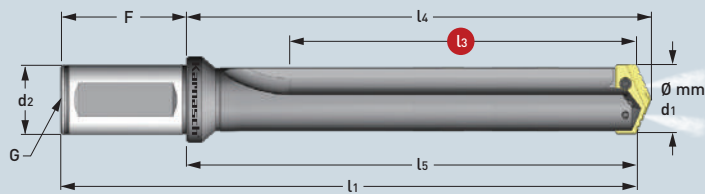

~ 15×D
Ultralang · Ultralength

Art.	€	l3 Nutzlänge Max. drill depth	l5 Körperlänge Body-length	l4 Neue REF.- Länge REF.-length	l1 Gesamtlänge Overall length	d2 Schaft-Ø Shank-Ø	F Schaftlänge Shank length	G Gewinde Pipe tap
		mm Zoll / Inch	mm Zoll / Inch	mm Zoll / Inch	mm Zoll / Inch	mm Zoll / Inch	mm Zoll / Inch	
• 22 1020 08790 0480 Ø 48,0-65,0 mm 1.8898-2.5591" MÖGLICH · POSSIBLE Ø 48,0-55,0 mm 1.8898-2.1654" OPTIMAL · OPTIMAL	975,85	879,0 mm 34.6063"	928,7 mm 36.5630"	933,5 mm 36.7520"	998,7 mm 39.3189"	40,0 mm 1.5748"	70,0 mm 2.7559"	1/4"
• 22 1020 08790 0560 Ø 56,0-65,0 mm 2.2047-2.5591" OPTIMAL · OPTIMAL	975,85	879,0 mm 34.6063"	928,7 mm 36.5630"	933,5 mm 36.7520"	998,7 mm 39.3189"	40,0 mm 1.5748"	70,0 mm 2.7559"	1/4"

Halter werden **ohne** Einsätze, inklusive 2× TORX Befestigungsschrauben und 1× TORX Schlüssel geliefert.
 Holders are delivered **without** inserts including 2× TORX-screws and 1× TORX wrench.

Ersatz-Torxschrauben und Schlüssel mit Drehmomentangabe
 Spare Torx-screws and wrench with torque specification

Ø Diameter		TORX		max. Drehmoment / Torque (N/cm)	Schlüssel / Wrench	
mm	Zoll / Inch		€			€
9,5-11,0	0.3740-0.4331	22 9010 0095	3,50	84	22 9011 0084	9,90
11,5-12,5	0.4528-0.4921	22 9010 0115	3,50	84	22 9011 0175	9,90
13,0-17,5	0.5118-0.6890	22 9010 0130	3,50	175	22 9011 0305	10,90
18,0-24,0	0.7087-0.9449	22 9010 0180	3,50	305	22 9011 0690	11,70
25,0-35,0	0.9843-1.3780	22 9010 0250	3,60	690	22 9011 1370	12,70
36,0-65,0	1.4173-2.5591	22 9010 0360	3,65	1370	22 9011 1750	18,70
64,0-114,0	2.5197-4.4882	22 9010 0640	3,70	1750		

Schnittdaten
Cutting data



1302-1311

Film
Movie



329





PULVERSTAHL · POWDER STEEL										HARTMETALL · CARBIDE									
Ø mm d1	Ø Zoll / Inch d1	22 2010 Pulverstahl 25 STEEL-TEC beschichtet Für Edelstahl, Stahl, Guss Powder steel 25 STEEL-TEC coated For stainless steel, steel, cast iron		22 2510 Pulverstahl 15 STEEL-TEC beschichtet Für legierte Stähle, Edelstahl, Stahl, Guss Powder steel 15 STEEL-TEC coated For alloy steel, stainless steel, steel, cast iron		22 3010 Pulverstahl 25 ALU-TEC beschichtet Für Alu, Messing, Kupfer Powder steel 25 ALU-TEC coated For alu, brass, copper		22 3510 Pulverstahl 15 ALU-TEC beschichtet Für Alu, Messing, Kupfer Powder steel 15 ALU-TEC coated For alloy steel, steel, cast iron		22 4010 Hartmetall 20/30 STEEL-TEC beschichtet Für Edelstahl, hochfester Stahl, gehärteter Stahl Carbide 20/30 STEEL-TEC coated For stainless steel, high strength alloys, hardened steel		22 4510 Hartmetall 20/30 STEEL-TEC beschichtet Für alle Gussarten Carbide 20/30 STEEL-TEC coated For all kinds of cast iron		22 5010 Hartmetall 20/30 ALU-TEC beschichtet Für Alu, Messing, Kupfer Carbide 20/30 ALU-TEC coated For alu, brass, copper		22 5510 Hartmetall 20/30 DIA-TEC beschichtet Für abrasive Materialien wie: GFK, CFK, Graphit Carbide 20/30 DIA-TEC coated For abrasive materials such as: fiberglass, carbon fiber, graphite			
Art.	€	Art.	€	Art.	€	Art.	€	Art.	€	Art.	€	Art.	€	Art.	€	Art.	€		
• 18,00	0.7087	22 2010 0180	36,00	-	-	22 3010 0180	40,35	-	-	22 4010 0180	44,80	22 4510 0180	44,80	22 5010 0180	48,90	22 5510 0180	102,55		
• 18,50	0.7283	22 2010 0185	36,00	-	-	22 3010 0185	40,35	-	-	22 4010 0185	44,80	22 4510 0185	44,80	22 5010 0185	48,90	22 5510 0185	102,55		
• 19,00	0.7480	22 2010 0190	36,00	-	-	22 3010 0190	40,35	-	-	22 4010 0190	44,80	22 4510 0190	44,80	22 5010 0190	48,90	22 5510 0190	102,55		
• 19,50	0.7677	22 2010 0195	36,00	-	-	22 3010 0195	40,35	-	-	22 4010 0195	44,80	22 4510 0195	44,80	22 5010 0195	48,90	22 5510 0195	102,55		
• 20,00	0.7874	22 2010 0200	36,00	-	-	22 3010 0200	40,35	-	-	22 4010 0200	44,80	22 4510 0200	44,80	22 5010 0200	48,90	22 5510 0200	102,55		
• 20,50	0.8071	22 2010 0205	36,00	-	-	22 3010 0205	40,35	-	-	22 4010 0205	44,80	22 4510 0205	44,80	22 5010 0205	48,90	22 5510 0205	118,55		
• 21,00	0.8268	22 2010 0210	36,00	-	-	22 3010 0210	40,35	-	-	22 4010 0210	44,80	22 4510 0210	44,80	22 5010 0210	48,90	22 5510 0210	118,55		
• 22,00	0.8661	22 2010 0220	36,00	-	-	22 3010 0220	40,35	-	-	22 4010 0220	44,80	22 4510 0220	44,80	22 5010 0220	48,90	22 5510 0220	118,55		
• 23,00	0.9055	22 2010 0230	36,00	-	-	22 3010 0230	40,35	-	-	22 4010 0230	44,80	22 4510 0230	44,80	22 5010 0230	48,90	22 5510 0230	118,55		
• 24,00	0.9449	22 2010 0240	36,00	-	-	22 3010 0240	40,35	-	-	22 4010 0240	44,80	22 4510 0240	44,80	22 5010 0240	48,90	22 5510 0240	118,55		
• 25,00	0.9843	22 2010 0250	42,15	-	-	22 3010 0250	45,45	-	-	22 4010 0250	52,45	22 4510 0250	52,45	22 5010 0250	55,55	22 5510 0250	125,20		
• 26,00	1.0236	22 2010 0260	42,15	-	-	22 3010 0260	45,45	-	-	22 4010 0260	52,45	22 4510 0260	52,45	22 5010 0260	55,55	22 5510 0260	125,20		
• 26,50	1.0433	22 2010 0265	42,15	-	-	22 3010 0265	45,45	-	-	22 4010 0265	52,45	22 4510 0265	52,45	22 5010 0265	55,55	22 5510 0265	125,20		
• 27,00	1.0630	22 2010 0270	42,15	-	-	22 3010 0270	45,45	-	-	22 4010 0270	52,45	22 4510 0270	52,45	22 5010 0270	55,55	22 5510 0270	125,20		
• 28,00	1.1024	22 2010 0280	42,15	-	-	22 3010 0280	45,45	-	-	22 4010 0280	52,45	22 4510 0280	52,45	22 5010 0280	55,55	22 5510 0280	125,20		
• 29,00	1.1417	22 2010 0290	42,15	-	-	22 3010 0290	45,45	-	-	22 4010 0290	52,45	22 4510 0290	52,45	22 5010 0290	55,55	22 5510 0290	125,20		
• 30,00	1.1811	22 2010 0300	42,15	-	-	22 3010 0300	45,45	-	-	22 4010 0300	52,45	22 4510 0300	52,45	22 5010 0300	55,55	22 5510 0300	125,20		
• 31,00	1.2205	22 2010 0310	42,15	-	-	22 3010 0310	45,45	-	-	22 4010 0310	52,45	22 4510 0310	52,45	22 5010 0310	55,55	22 5510 0310	125,20		
• 32,00	1.2598	22 2010 0320	42,15	-	-	22 3010 0320	45,45	-	-	22 4010 0320	52,45	22 4510 0320	52,45	22 5010 0320	55,55	22 5510 0320	125,20		
• 33,00	1.2992	22 2010 0330	42,15	-	-	22 3010 0330	45,45	-	-	22 4010 0330	52,45	22 4510 0330	52,45	22 5010 0330	55,55	22 5510 0330	132,90		
• 34,00	1.3386	22 2010 0340	42,15	-	-	22 3010 0340	45,45	-	-	22 4010 0340	52,45	22 4510 0340	52,45	22 5010 0340	55,55	22 5510 0340	132,90		
• 35,00	1.3780	22 2010 0350	42,15	-	-	22 3010 0350	45,45	-	-	22 4010 0350	52,45	22 4510 0350	52,45	22 5010 0350	55,55	22 5510 0350	132,90		
• 36,00	1.4173	22 2010 0360	57,75	-	-	22 3010 0360	59,50	-	-	-	-	-	-	-	-	-	-		
• 37,00	1.4567	22 2010 0370	57,75	-	-	22 3010 0370	59,50	-	-	-	-	-	-	-	-	-	-		
• 38,00	1.4961	22 2010 0380	57,75	-	-	22 3010 0380	59,50	-	-	-	-	-	-	-	-	-	-		
• 39,00	1.5354	22 2010 0390	57,75	-	-	22 3010 0390	59,50	-	-	-	-	-	-	-	-	-	-		
• 40,00	1.5748	22 2010 0400	57,75	-	-	22 3010 0400	59,50	-	-	-	-	-	-	-	-	-	-		
• 41,00	1.6142	22 2010 0410	57,75	-	-	22 3010 0410	59,50	-	-	-	-	-	-	-	-	-	-		
• 42,00	1.6535	22 2010 0420	57,75	-	-	22 3010 0420	59,50	-	-	-	-	-	-	-	-	-	-		
• 43,00	1.6929	22 2010 0430	57,75	-	-	22 3010 0430	59,50	-	-	-	-	-	-	-	-	-	-		
• 44,00	1.7323	22 2010 0440	57,75	-	-	22 3010 0440	59,50	-	-	-	-	-	-	-	-	-	-		
• 45,00	1.7717	22 2010 0450	57,75	-	-	22 3010 0450	59,50	-	-	-	-	-	-	-	-	-	-		
• 46,00	1.8110	22 2010 0460	57,75	-	-	22 3010 0460	59,50	-	-	-	-	-	-	-	-	-	-		
• 47,00	1.8504	22 2010 0470	57,75	-	-	22 3010 0470	59,50	-	-	-	-	-	-	-	-	-	-		

↓
Weitere Ø bis maximal Ø 65 mm | 2.5591" in 5xD siehe Seite 334/335
Further Ø up to Ø 65 mm | 2.5591" in 5xD see page 334/335

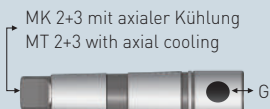

Bei Morsekonus 2+3 ist eine axiale Kühlung ohne Kühlmittelring möglich.
Hierzu muss das Gewinde des Kühlmittelringes (G) mit einer Schraube geschlossen werden.

With morse cone 2+3, axial cooling without coolant ring is possible.
For this, the thread of the coolant ring (G) must be closed with a screw.

Schraube für MK 2 / Screw for MT 2 = RC 1/16" **22 1030 0231 802 € 0,30**

Schraube für MK 3 / Screw for MT 3 = RC 1/8" **22 1030 0231 803 € 0,30**

Schnittdaten
Cutting data

1302-1311

Film
Movie

MK 2+3 mit axialer Kühlung
MT 2+3 with axial cooling



MK 2,3,4,5 – Radiale Kühlung
mit Kühlmittelring
MT 2,3,4,5 – Radial coolant
with oil ring

Morsekegel
ISO 296 Typ BEK ·
Morse taper shank
ISO 296 type BEK

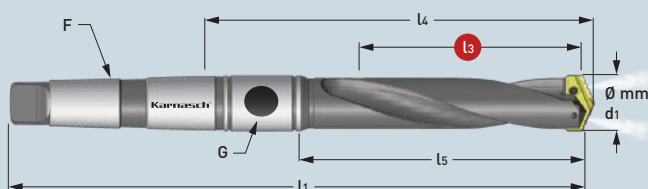
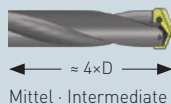

Art.	€	mm Zoll / Inch	mm Zoll / Inch	mm Zoll / Inch	mm Zoll / Inch			Art.	€
<ul style="list-style-type: none"> 22 1030 01207 0180 Ø 18,0-24,0 mm 0.7087-0.9449" MÖGLICH · POSSIBLE Ø 18,0-21,0 mm 0.7087-0.8268" OPTIMAL · OPTIMAL 22 1030 01207 0220 Ø 22,0-24,0 mm 0.8661-0.9449" OPTIMAL · OPTIMAL 	164,35	120,7 mm 4.7519"	149,2 mm 5.8740"	193,3 mm 7.6102"	283,3 mm 11.1535"	3	1/8"	• 22 9002 02540	24,85
<ul style="list-style-type: none"> 22 1030 01365 0250 Ø 25,0-35,0 mm 0.9843-1.3780" MÖGLICH · POSSIBLE Ø 25,0-29,0 mm 0.9843-1.1417" OPTIMAL · OPTIMAL 22 1030 01365 0300 Ø 30,0-35,0 mm 1.1811-1.3780" OPTIMAL · OPTIMAL 	212,80	136,5 mm 5.3740"	165,1 mm 6.5000"	218,4 mm 8.5984"	331,8 mm 13.0630"	4	1/8" Halter Holder 25,0-35,0 mm	• 22 9002 03175	32,20
<ul style="list-style-type: none"> 22 1030 01651 0360 Ø 36,0-47,0 mm 1.4173-1.8504" MÖGLICH · POSSIBLE Ø 36,0-41,0 mm 1.4173-1.6142" OPTIMAL · OPTIMAL 22 1030 01651 0420 Ø 42,0-47,0 mm 1.6535-1.8504" OPTIMAL · OPTIMAL 	300,15	165,1 mm 6.5000"	196,9 mm 7.7519"	250,9 mm 9.8779"	363,6 mm 14.3150"	4	1/4" Halter Holder 30,0-35,0 mm		

Halter werden **ohne** Einsätze, inklusive 2x TORX Befestigungsschrauben und 1x TORX Schlüssel geliefert.
Holders are delivered **without** inserts including 2x TORX-screws and 1x TORX wrench.

Für Maschinen ohne axiale/radiale Kühlmittelzufuhr kann ein Kühlmittelring auf den Halter montiert werden. Details siehe Seite 356
For machines without radial/axial coolant supply a oil ring can be mounted on the holder. Details see page 356



Ersatz-Torxschrauben und Schlüssel mit Drehmomentangabe
Spare Torx-screws and wrench with torque specification

Ø Diameter		TORX		max. Drehmoment / Torque (N/cm)	Schlüssel / Wrench	
mm	Zoll / Inch		€			€
9,5-11,0	0.3740-0.4331	22 9010 0095	3,50	84	22 9011 0084	9,90
11,5-12,5	0.4528-0.4921	22 9010 0115	3,50	84	22 9011 0175	9,90
13,0-17,5	0.5118-0.6890	22 9010 0130	3,50	175	22 9011 0305	10,90
18,0-24,0	0.7087-0.9449	22 9010 0180	3,50	305	22 9011 0690	11,70
25,0-35,0	0.9843-1.3780	22 9010 0250	3,60	690	22 9011 1370	12,70
36,0-65,0	1.4173-2.5591	22 9010 0360	3,65	1370	22 9011 1750	18,70
64,0-114,0	2.5197-4.4882	22 9010 0640	3,70	1750		



PULVERSTAHL · POWDER STEEL

HARTMETALL · CARBIDE

Ø mm / d1	Ø Zoll / Inch d1	22 2010		22 2510		22 3010		22 3510		22 4010		22 4510		22 5010		22 5510	
		Art.	€	Art.	€	Art.	€	Art.	€	Art.	€	Art.	€	Art.	€	Art.	€
● 9,50	0.3740	22 2010 0095	24,85	-	-	22 3010 0095	26,05	-	-	22 4010 0095	29,30	22 4510 0095	29,30	22 5010 0095	30,45	22 5510 0095	66,40
○ 9,80	0.3858	-	-	-	-	-	-	-	-	-	-	-	-	-	-	-	-
● 10,00	0.3937	22 2010 0100	24,85	-	-	22 3010 0100	26,05	-	-	22 4010 0100	29,30	22 4510 0100	29,30	22 5010 0100	30,45	22 5510 0100	66,40
● 10,20	0.4016	22 2010 0102	24,85	-	-	22 3010 0102	26,05	-	-	22 4010 0102	29,30	22 4510 0102	29,30	22 5010 0102	30,45	22 5510 0102	66,40
● 10,50	0.4134	22 2010 0105	24,85	-	-	22 3010 0105	26,05	-	-	22 4010 0105	29,30	22 4510 0105	29,30	22 5010 0105	30,45	22 5510 0105	66,40
● 10,80	0.4252	22 2010 0108	24,85	-	-	22 3010 0108	26,05	-	-	22 4010 0108	29,30	22 4510 0108	29,30	22 5010 0108	30,45	22 5510 0108	66,40
● 11,00	0.4331	22 2010 0110	24,85	-	-	22 3010 0110	26,05	-	-	22 4010 0110	29,30	22 4510 0110	29,30	22 5010 0110	30,45	22 5510 0110	66,40
● 11,50	0.4528	22 2010 0115	24,85	-	-	22 3010 0115	26,05	-	-	22 4010 0115	29,30	22 4510 0115	29,30	22 5010 0115	30,45	22 5510 0115	66,40
● 12,00	0.4724	22 2010 0120	24,85	-	-	22 3010 0120	26,05	-	-	22 4010 0120	29,30	22 4510 0120	29,30	22 5010 0120	30,45	22 5510 0120	66,40
● 12,50	0.4921	22 2010 0125	24,85	-	-	22 3010 0125	26,05	-	-	22 4010 0125	29,30	22 4510 0125	29,30	22 5010 0125	30,45	22 5510 0125	66,40
● 13,00	0.5118	22 2010 0130	28,30	-	-	22 3010 0130	28,95	-	-	22 4010 0130	34,45	22 4510 0130	34,45	22 5010 0130	35,10	22 5510 0130	92,70
● 13,50	0.5315	22 2010 0135	28,30	-	-	22 3010 0135	28,95	-	-	22 4010 0135	34,45	22 4510 0135	34,45	22 5010 0135	35,10	22 5510 0135	92,70
● 14,00	0.5512	22 2010 0140	28,30	-	-	22 3010 0140	28,95	-	-	22 4010 0140	34,45	22 4510 0140	34,45	22 5010 0140	35,10	22 5510 0140	92,70
● 14,50	0.5709	22 2010 0145	28,30	-	-	22 3010 0145	28,95	-	-	22 4010 0145	34,45	22 4510 0145	34,45	22 5010 0145	35,10	22 5510 0145	92,70
● 15,00	0.5906	22 2010 0150	28,30	-	-	22 3010 0150	28,95	-	-	22 4010 0150	34,45	22 4510 0150	34,45	22 5010 0150	35,10	22 5510 0150	92,70
● 15,50	0.6102	22 2010 0155	28,30	-	-	22 3010 0155	28,95	-	-	22 4010 0155	34,45	22 4510 0155	34,45	22 5010 0155	35,10	22 5510 0155	92,70
● 16,00	0.6299	22 2010 0160	28,30	-	-	22 3010 0160	28,95	-	-	22 4010 0160	34,45	22 4510 0160	34,45	22 5010 0160	35,10	22 5510 0160	92,70
● 16,50	0.6496	22 2010 0165	28,30	-	-	22 3010 0165	28,95	-	-	22 4010 0165	34,45	22 4510 0165	34,45	22 5010 0165	35,10	22 5510 0165	92,70
● 17,00	0.6693	22 2010 0170	28,30	-	-	22 3010 0170	28,95	-	-	22 4010 0170	34,45	22 4510 0170	34,45	22 5010 0170	35,10	22 5510 0170	92,70
● 17,50	0.6890	22 2010 0175	28,30	-	-	22 3010 0175	28,95	-	-	22 4010 0175	34,45	22 4510 0175	34,45	22 5010 0175	35,10	22 5510 0175	92,70
● 18,00	0.7087	22 2010 0180	36,00	-	-	22 3010 0180	40,35	-	-	22 4010 0180	44,80	22 4510 0180	44,80	22 5010 0180	48,90	22 5510 0180	102,55
● 18,50	0.7283	22 2010 0185	36,00	-	-	22 3010 0185	40,35	-	-	22 4010 0185	44,80	22 4510 0185	44,80	22 5010 0185	48,90	22 5510 0185	102,55
● 19,00	0.7480	22 2010 0190	36,00	-	-	22 3010 0190	40,35	-	-	22 4010 0190	44,80	22 4510 0190	44,80	22 5010 0190	48,90	22 5510 0190	102,55
● 19,50	0.7677	22 2010 0195	36,00	-	-	22 3010 0195	40,35	-	-	22 4010 0195	44,80	22 4510 0195	44,80	22 5010 0195	48,90	22 5510 0195	102,55
● 20,00	0.7874	22 2010 0200	36,00	-	-	22 3010 0200	40,35	-	-	22 4010 0200	44,80	22 4510 0200	44,80	22 5010 0200	48,90	22 5510 0200	102,55
● 20,50	0.8071	22 2010 0205	36,00	-	-	22 3010 0205	40,35	-	-	22 4010 0205	44,80	22 4510 0205	44,80	22 5010 0205	48,90	22 5510 0205	118,55
● 21,00	0.8268	22 2010 0210	36,00	-	-	22 3010 0210	40,35	-	-	22 4010 0210	44,80	22 4510 0210	44,80	22 5010 0210	48,90	22 5510 0210	118,55
● 22,00	0.8661	22 2010 0220	36,00	-	-	22 3010 0220	40,35	-	-	22 4010 0220	44,80	22 4510 0220	44,80	22 5010 0220	48,90	22 5510 0220	118,55
● 23,00	0.9055	22 2010 0230	36,00	-	-	22 3010 0230	40,35	-	-	22 4010 0230	44,80	22 4510 0230	44,80	22 5010 0230	48,90	22 5510 0230	118,55
● 24,00	0.9449	22 2010 0240	36,00	-	-	22 3010 0240	40,35	-	-	22 4010 0240	44,80	22 4510 0240	44,80	22 5010 0240	48,90	22 5510 0240	118,55
● 25,00	0.9843	22 2010 0250	42,15	-	-	22 3010 0250	45,45	-	-	22 4010 0250	52,45	22 4510 0250	52,45	22 5010 0250	55,55	22 5510 0250	125,20
● 26,00	1.0236	22 2010 0260	42,15	-	-	22 3010 0260	45,45	-	-	22 4010 0260	52,45	22 4510 0260	52,45	22 5010 0260	55,55	22 5510 0260	125,20
● 26,50	1.0433	22 2010 0265	42,15	-	-	22 3010 0265	45,45	-	-	22 4010 0265	52,45	22 4510 0265	52,45	22 5010 0265	55,55	22 5510 0265	125,20
● 27,00	1.0630	22 2010 0270	42,15	-	-	22 3010 0270	45,45	-	-	22 4010 0270	52,45	22 4510 0270	52,45	22 5010 0270	55,55	22 5510 0270	125,20
● 28,00	1.1024	22 2010 0280	42,15	-	-	22 3010 0280	45,45	-	-	22 4010 0280	52,45	22 4510 0280	52,45	22 5010 0280	55,55	22 5510 0280	125,20
● 29,00	1.1417	22 2010 0290	42,15	-	-	22 3010 0290	45,45	-	-	22 4010 0290	52,45	22 4510 0290	52,45	22 5010 0290	55,55	22 5510 0290	125,20
● 30,00	1.1811	22 2010 0300	42,15	-	-	22 3010 0300	45,45	-	-	22 4010 0300	52,45	22 4510 0300	52,45	22 5010 0300	55,55	22 5510 0300	125,20
● 31,00	1.2205	22 2010 0310	42,15	-	-	22 3010 0310	45,45	-	-	22 4010 0310	52,45	22 4510 0310	52,45	22 5010 0310	55,55	22 5510 0310	125,20
● 32,00	1.2598	22 2010 0320	42,15	-	-	22 3010 0320	45,45	-	-	22 4010 0320	52,45	22 4510 0320	52,45	22 5010 0320	55,55	22 5510 0320	125,20
● 33,00	1.2992	22 2010 0330	42,15	-	-	22 3010 0330	45,45	-	-	22 4010 0330	52,45	22 4510 0330	52,45	22 5010 0330	55,55	22 5510 0330	132,90
● 34,00	1.3386	22 2010 0340	42,15	-	-	22 3010 0340	45,45	-	-	22 4010 0340	52,45	22 4510 0340	52,45	22 5010 0340	55,55	22 5510 0340	132,90
● 35,00	1.3780	22 2010 0350	42,15	-	-	22 3010 0350	45,45	-	-	22 4010 0350	52,45	22 4510 0350	52,45	22 5010 0350	55,55	22 5510 0350	132,90
● 36,00	1.4173	22 2010 0360	57,75	-	-	22 3010 0360	59,50	-	-	-	-	-	-	-	-	-	-
● 37,00	1.4567	22 2010 0370	57,75	-	-	22 3010 0370	59,50	-	-	-	-	-	-	-	-	-	-
● 38,00	1.4961	22 2010 0380	57,75	-	-	22 3010 0380	59,50	-	-	-	-	-	-	-	-	-	-
● 39,00	1.5354	22 2010 0390	57,75	-	-	22 3010 0390	59,50	-	-	-	-	-	-	-	-	-	-
● 40,00	1.5748	22 2010 0400	57,75	-	-	22 3010 0400	59,50	-	-	-	-	-	-	-	-	-	-
● 41,00	1.6142	22 2010 0410	57,75	-	-	22 3010 0410	59,50	-	-	-	-	-	-	-	-	-	-
● 42,00	1.6535	22 2010 0420	57,75	-	-	22 3010 0420	59,50	-	-	-	-	-	-	-	-	-	-
● 43,00	1.6929	22 2010 0430	57,75	-	-	22 3010 0430	59,50	-	-	-	-	-	-	-	-	-	-
● 44,00	1.7323	22 2010 0440	57,75	-	-	22 3010 0440	59,50	-	-	-	-	-	-	-	-	-	-
● 45,00	1.7717	22 2010 0450	57,75	-	-	22 3010 0450	59,50	-	-	-	-	-	-	-	-	-	-
● 46,00	1.8110	22 2010 0460	57,75	-	-	22 3010 0460	59,50	-	-	-	-	-	-	-	-	-	-
● 47,00	1.8504	22 2010 0470	57,75	-	-	22 3010 0470	59,50	-	-	-	-	-	-	-	-	-	-

Fortsetzung Seite 334 · Continued page 334

MK 2+3 mit axialer Kühlung
MT 2+3 with axial cooling



MK 2,3,4,5 – Radiale Kühlung
mit Kühlmittelring
MT 2,3,4,5 – Radial coolant
with oil ring

Morsekegel
ISO 296 Typ BEK ·
Morse taper shank
ISO 296 type BEK



← ~ 5xD →
Mittel · Intermediate



Spiral genutet ·
Helical flute

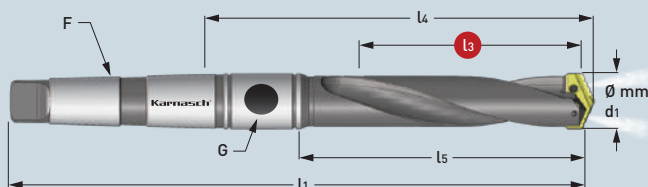

Art.	€	mm Zoll / Inch	mm Zoll / Inch	mm Zoll / Inch	mm Zoll / Inch	F	G	Art.	€
		Max. drill depth	Body-length	Neue REF.-Länge	Overall length	Morsekegel	Gewinde		
				REF.-length		Morse taper	Pipe tap		
• 22 1030 00603 0095 Ø 9,5-11,0 mm 0.3740-0.4331" OPTIMAL · OPTIMAL	127,50	60,3 mm 2.3740"	80,2 mm 3.1574"	116,7 mm 4.5944"	188,9 mm 7.4370"	2	1/16"	• 22 9002 01905 22,10	
• 22 1030 00603 0115 Ø 11,5-12,5 mm 0.4528-0.4921" OPTIMAL · OPTIMAL	127,50	60,3 mm 2.3740"	80,2 mm 3.1574"	116,7 mm 4.5944"	188,9 mm 7.4370"	2	1/16"		
• 22 1030 00635 0130 Ø 13,0-17,5 mm 0.5118-0.6890" MÖGLICH · POSSIBLE Ø 13,0-15,0 mm 0.5118-0.5906" OPTIMAL · OPTIMAL	134,65	63,5 mm 2.5000"	84,1 mm 3.3110"	121,0 mm 4.7637"	192,9 mm 7.5944"	2	1/16"		
• 22 1030 00635 0155 Ø 15,5-17,5 mm 0.6102-0.6890" OPTIMAL · OPTIMAL	134,65	63,5 mm 2.5000"	84,1 mm 3.3110"	121,0 mm 4.7637"	192,9 mm 7.5944"	2	1/16"		
• 22 1030 01715 0180 Ø 18,0-24,0 mm 0.7087-0.9449" MÖGLICH · POSSIBLE Ø 18,0-21,0 mm 0.7087-0.8268" OPTIMAL · OPTIMAL	185,90	171,5 mm 6.7519"	200,0 mm 7.8740"	244,1 mm 9.6102"	334,2 mm 13.1575"	3	1/8"	• 22 9002 02540 24,85	
• 22 1030 01715 0220 Ø 22,0-24,0 mm 0.8661-0.9449" OPTIMAL · OPTIMAL	185,90	171,5 mm 6.7519"	200,0 mm 7.8740"	244,1 mm 9.6102"	334,2 mm 13.1575"	3	1/8"		
• 22 1030 01873 0250 Ø 25,0-35,0 mm 0.9843-1.3780" MÖGLICH · POSSIBLE Ø 25,0-29,0 mm 0.9843-1.1417" OPTIMAL · OPTIMAL	236,50	187,3 mm 7.3740"	215,9 mm 8.5000"	262,0 mm 10.3150"	375,4 mm 14.7795"	4	1/8" Halter Holder 25,0-35,0 mm	• 22 9002 03175 32,20	
• 22 1030 01873 0300 Ø 30,0-35,0 mm 1.1811-1.3780" OPTIMAL · OPTIMAL	236,50	187,3 mm 7.3740"	215,9 mm 8.5000"	269,2 mm 10.5984"	382,6 mm 15.0630"	4	1/4" Halter Holder 30,0-35,0 mm		
• 22 1030 02095 0360 Ø 36,0-47,0 mm 1.4173-1.8504" MÖGLICH · POSSIBLE Ø 36,0-41,0 mm 1.4173-1.6142" OPTIMAL · OPTIMAL	322,75	209,5 mm 8.2480"	241,3 mm 9.5000"	295,3 mm 11.6260"	408,0 mm 16.0630"	4	1/4"		
• 22 1030 02095 0420 Ø 42,0-47,0 mm 1.6535-1.8504" OPTIMAL · OPTIMAL	322,75	209,5 mm 8.2480"	241,3 mm 9.5000"	295,3 mm 11.6260"	408,0 mm 16.0630"	4	1/4"		

Fortsetzung Seite 335 · Continued page 335

Schnittdaten
Cutting data

Film
Movie

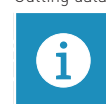

1302-1311



333





PULVERSTAHL · POWDER STEEL

HARTMETALL · CARBIDE

Ø mm d1		Ø Zoll / Inch d1		22 2010		22 2510		22 3010		22 3510		22 4010		22 4510		22 5010		22 5510	
				Pulverstahl 25 STEEL-TEC beschichtet Für Edelstahl, Stahl, Guss Powder steel 25 STEEL-TEC coated For stainless steel, steel, cast iron		Pulverstahl 15 STEEL-TEC beschichtet Für legierte Stähle, Edelstahl, Stahl, Guss Powder steel 15 STEEL-TEC coated For alloy steel, stainless steel, steel, cast iron		Pulverstahl 25 ALU-TEC beschichtet Für Alu, Messing, Kupfer Powder steel 25 ALU-TEC coated For alu, brass, copper		Pulverstahl 15 ALU-TEC beschichtet Für Alu, Messing, Kupfer Powder steel 15 ALU-TEC coated For alloy steel, steel, cast iron		Hartmetall 20/30 STEEL-TEC beschichtet Für Edelstahl, hochfester Stahl, gehärteter Stahl Carbide 20/30 STEEL-TEC coated For stainless steel, high strength alloys, hardened steel		Hartmetall 20/30 STEEL-TEC beschichtet Für alle Gussarten Carbide 20/30 STEEL-TEC coated For all kinds of cast iron		Hartmetall 20/30 ALU-TEC beschichtet Für Alu, Messing, Kupfer Carbide 20/30 ALU-TEC coated For alu, brass, copper		Hartmetall 20/30 DIA-TEC beschichtet Für abrasive Materialien wie: GFK, CFK, Graphit Carbide 20/30 DIA-TEC coated For abrasive materials such as: fiberglass, carbon fiber, graphite	
Art.	€	Art.	€	Art.	€	Art.	€	Art.	€	Art.	€	Art.	€	Art.	€	Art.	€	Art.	€
• 48,00	1.8898	22 2010 0480	82,65	-	-	22 3010 0480	82,65	-	-	-	-	-	-	-	-	-	-	-	-
• 49,00	1.9291	22 2010 0490	82,65	-	-	22 3010 0490	82,65	-	-	-	-	-	-	-	-	-	-	-	-
• 50,00	1.9685	22 2010 0500	82,65	-	-	22 3010 0500	82,65	-	-	-	-	-	-	-	-	-	-	-	-
• 51,00	2.0079	22 2010 0510	82,65	-	-	22 3010 0510	82,65	-	-	-	-	-	-	-	-	-	-	-	-
• 52,00	2.0472	22 2010 0520	82,65	-	-	22 3010 0520	82,65	-	-	-	-	-	-	-	-	-	-	-	-
• 53,00	2.0866	22 2010 0530	82,65	-	-	22 3010 0530	82,65	-	-	-	-	-	-	-	-	-	-	-	-
• 54,00	2.1260	22 2010 0540	82,65	-	-	22 3010 0540	82,65	-	-	-	-	-	-	-	-	-	-	-	-
• 55,00	2.1654	22 2010 0550	82,65	-	-	22 3010 0550	82,65	-	-	-	-	-	-	-	-	-	-	-	-
• 56,00	2.2047	22 2010 0560	82,65	-	-	22 3010 0560	82,65	-	-	-	-	-	-	-	-	-	-	-	-
• 57,00	2.2441	22 2010 0570	82,65	-	-	22 3010 0570	82,65	-	-	-	-	-	-	-	-	-	-	-	-
• 58,00	2.2835	22 2010 0580	82,65	-	-	22 3010 0580	82,65	-	-	-	-	-	-	-	-	-	-	-	-
• 59,00	2.3228	22 2010 0590	82,65	-	-	22 3010 0590	82,65	-	-	-	-	-	-	-	-	-	-	-	-
• 60,00	2.3622	22 2010 0600	82,65	-	-	22 3010 0600	82,65	-	-	-	-	-	-	-	-	-	-	-	-
• 61,00	2.4016	22 2010 0610	82,65	-	-	22 3010 0610	82,65	-	-	-	-	-	-	-	-	-	-	-	-
• 62,00	2.4409	22 2010 0620	82,65	-	-	22 3010 0620	82,65	-	-	-	-	-	-	-	-	-	-	-	-
• 63,00	2.4803	22 2010 0630	82,65	-	-	22 3010 0630	82,65	-	-	-	-	-	-	-	-	-	-	-	-
• 64,00	2.5197	22 2010 0640	82,65	-	-	22 3010 0640	82,65	-	-	-	-	-	-	-	-	-	-	-	-
• 65,00	2.5591	22 2010 0650	82,65	-	-	22 3010 0650	82,65	-	-	-	-	-	-	-	-	-	-	-	-

MK 2+3 mit axialer Kühlung
MT 2+3 with axial cooling

MK 2,3,4,5 – Radiale Kühlung
mit Kühlmittelring
MT 2,3,4,5 – Radial coolant
with oil ring

Morsekegel
ISO 296 Typ BEK ·
Morse taper shank
ISO 296 type BEK

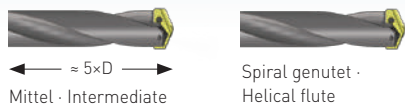
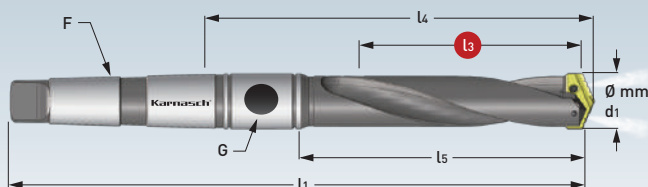

Art.	€	mm Zoll / Inch	mm Zoll / Inch	mm Zoll / Inch	mm Zoll / Inch			Art.	€
22 1030 02318 0480	345,60	231,8 mm 9.1259"	266,7 mm 10.5000"	320,7 mm 12.6260"	465,1 mm 18.3110"	5	1/4"	22 9002 04445	42,30
22 1030 02318 0560	345,60	231,8 mm 9.1259"	266,7 mm 10.5000"	320,7 mm 12.6260"	465,1 mm 18.3110"	5	1/4"		

Halter werden **ohne** Einsätze, inklusive 2× TORX Befestigungsschrauben und 1× TORX Schlüssel geliefert.
Holders are delivered **without** inserts including 2× TORX-screws and 1× TORX wrench.

Für Maschinen ohne axiale/radiale Kühlmittelzufuhr kann ein Kühlmittelring auf den Halter montiert werden. Details siehe Seite 356
For machines without radial/axial coolant supply a oil ring can be mounted on the holder. Details see page 356



Ersatz-Torxschrauben und Schlüssel mit Drehmomentangabe
Spare Torx-screws and wrench with torque specification

Ø Diameter		TORX		max. Drehmoment / Torque (N/cm)	Schlüssel / Wrench	
mm	Zoll / Inch		€			€
9,5-11,0	0.3740-0.4331	22 9010 0095	3,50	84	22 9011 0084	9,90
11,5-12,5	0.4528-0.4921	22 9010 0115	3,50	84	22 9011 0175	9,90
13,0-17,5	0.5118-0.6890	22 9010 0130	3,50	175	22 9011 0305	10,90
18,0-24,0	0.7087-0.9449	22 9010 0180	3,50	305	22 9011 0690	11,70
25,0-35,0	0.9843-1.3780	22 9010 0250	3,60	690	22 9011 1370	12,70
36,0-65,0	1.4173-2.5591	22 9010 0360	3,65	1370	22 9011 1750	18,70
64,0-114,0	2.5197-4.4882	22 9010 0640	3,70	1750		



Bei Morsekonus 2+3 ist eine axiale Kühlung ohne Kühlmittelring möglich.
Hierzu muss das Gewinde des Kühlmittelringes (G) mit einer Schraube geschlossen werden.

With morse cone 2+3, axial cooling without coolant ring is possible.
For this, the thread of the coolant ring (G) must be closed with a screw.

Schraube für MK 2 / Screw for MT 2 = RC 1/16" **22 1030 0231 802** € 0,30

Schraube für MK 3 / Screw for MT 3 = RC 1/8" **22 1030 0231 803** € 0,30

Schnittdaten
Cutting data

Film
Movie



1302-1311

335



PULVERSTAHL · POWDER STEEL

HARTMETALL · CARBIDE

Ø mm d1	Ø Zoll / Inch d1	22 2010		22 2510		22 3010		22 3510		22 4010		22 4510		22 5010		22 5510	
		Art.	€	Art.	€	Art.	€	Art.	€	Art.	€	Art.	€	Art.	€	Art.	€
• 9,50	0.3740	22 2010 0095	24,85	-	-	22 3010 0095	26,05	-	-	22 4010 0095	29,30	22 4510 0095	29,30	22 5010 0095	30,45	22 5510 0095	66,40
○ 9,80	0.3858	-	-	-	-	-	-	-	-	-	-	-	-	-	-	-	-
• 10,00	0.3937	22 2010 0100	24,85	-	-	22 3010 0100	26,05	-	-	22 4010 0100	29,30	22 4510 0100	29,30	22 5010 0100	30,45	22 5510 0100	66,40
• 10,20	0.4016	22 2010 0102	24,85	-	-	22 3010 0102	26,05	-	-	22 4010 0102	29,30	22 4510 0102	29,30	22 5010 0102	30,45	22 5510 0102	66,40
• 10,50	0.4134	22 2010 0105	24,85	-	-	22 3010 0105	26,05	-	-	22 4010 0105	29,30	22 4510 0105	29,30	22 5010 0105	30,45	22 5510 0105	66,40
• 10,80	0.4252	22 2010 0108	24,85	-	-	22 3010 0108	26,05	-	-	22 4010 0108	29,30	22 4510 0108	29,30	22 5010 0108	30,45	22 5510 0108	66,40
• 11,00	0.4331	22 2010 0110	24,85	-	-	22 3010 0110	26,05	-	-	22 4010 0110	29,30	22 4510 0110	29,30	22 5010 0110	30,45	22 5510 0110	66,40
• 11,50	0.4528	22 2010 0115	24,85	-	-	22 3010 0115	26,05	-	-	22 4010 0115	29,30	22 4510 0115	29,30	22 5010 0115	30,45	22 5510 0115	66,40
• 12,00	0.4724	22 2010 0120	24,85	-	-	22 3010 0120	26,05	-	-	22 4010 0120	29,30	22 4510 0120	29,30	22 5010 0120	30,45	22 5510 0120	66,40
• 12,50	0.4921	22 2010 0125	24,85	-	-	22 3010 0125	26,05	-	-	22 4010 0125	29,30	22 4510 0125	29,30	22 5010 0125	30,45	22 5510 0125	66,40
• 13,00	0.5118	22 2010 0130	28,30	-	-	22 3010 0130	28,95	-	-	22 4010 0130	34,45	22 4510 0130	34,45	22 5010 0130	35,10	22 5510 0130	92,70
• 13,50	0.5315	22 2010 0135	28,30	-	-	22 3010 0135	28,95	-	-	22 4010 0135	34,45	22 4510 0135	34,45	22 5010 0135	35,10	22 5510 0135	92,70
• 14,00	0.5512	22 2010 0140	28,30	-	-	22 3010 0140	28,95	-	-	22 4010 0140	34,45	22 4510 0140	34,45	22 5010 0140	35,10	22 5510 0140	92,70
• 14,50	0.5709	22 2010 0145	28,30	-	-	22 3010 0145	28,95	-	-	22 4010 0145	34,45	22 4510 0145	34,45	22 5010 0145	35,10	22 5510 0145	92,70
• 15,00	0.5906	22 2010 0150	28,30	-	-	22 3010 0150	28,95	-	-	22 4010 0150	34,45	22 4510 0150	34,45	22 5010 0150	35,10	22 5510 0150	92,70
• 15,50	0.6102	22 2010 0155	28,30	-	-	22 3010 0155	28,95	-	-	22 4010 0155	34,45	22 4510 0155	34,45	22 5010 0155	35,10	22 5510 0155	92,70
• 16,00	0.6299	22 2010 0160	28,30	-	-	22 3010 0160	28,95	-	-	22 4010 0160	34,45	22 4510 0160	34,45	22 5010 0160	35,10	22 5510 0160	92,70
• 16,50	0.6496	22 2010 0165	28,30	-	-	22 3010 0165	28,95	-	-	22 4010 0165	34,45	22 4510 0165	34,45	22 5010 0165	35,10	22 5510 0165	92,70
• 17,00	0.6693	22 2010 0170	28,30	-	-	22 3010 0170	28,95	-	-	22 4010 0170	34,45	22 4510 0170	34,45	22 5010 0170	35,10	22 5510 0170	92,70
• 17,50	0.6890	22 2010 0175	28,30	-	-	22 3010 0175	28,95	-	-	22 4010 0175	34,45	22 4510 0175	34,45	22 5010 0175	35,10	22 5510 0175	92,70
• 18,00	0.7087	22 2010 0180	36,00	-	-	22 3010 0180	40,35	-	-	22 4010 0180	44,80	22 4510 0180	44,80	22 5010 0180	48,90	22 5510 0180	102,55
• 18,50	0.7283	22 2010 0185	36,00	-	-	22 3010 0185	40,35	-	-	22 4010 0185	44,80	22 4510 0185	44,80	22 5010 0185	48,90	22 5510 0185	102,55
• 19,00	0.7480	22 2010 0190	36,00	-	-	22 3010 0190	40,35	-	-	22 4010 0190	44,80	22 4510 0190	44,80	22 5010 0190	48,90	22 5510 0190	102,55
• 19,50	0.7677	22 2010 0195	36,00	-	-	22 3010 0195	40,35	-	-	22 4010 0195	44,80	22 4510 0195	44,80	22 5010 0195	48,90	22 5510 0195	102,55
• 20,00	0.7874	22 2010 0200	36,00	-	-	22 3010 0200	40,35	-	-	22 4010 0200	44,80	22 4510 0200	44,80	22 5010 0200	48,90	22 5510 0200	102,55
• 20,50	0.8071	22 2010 0205	36,00	-	-	22 3010 0205	40,35	-	-	22 4010 0205	44,80	22 4510 0205	44,80	22 5010 0205	48,90	22 5510 0205	118,55
• 21,00	0.8268	22 2010 0210	36,00	-	-	22 3010 0210	40,35	-	-	22 4010 0210	44,80	22 4510 0210	44,80	22 5010 0210	48,90	22 5510 0210	118,55
• 22,00	0.8661	22 2010 0220	36,00	-	-	22 3010 0220	40,35	-	-	22 4010 0220	44,80	22 4510 0220	44,80	22 5010 0220	48,90	22 5510 0220	118,55
• 23,00	0.9055	22 2010 0230	36,00	-	-	22 3010 0230	40,35	-	-	22 4010 0230	44,80	22 4510 0230	44,80	22 5010 0230	48,90	22 5510 0230	118,55
• 24,00	0.9449	22 2010 0240	36,00	-	-	22 3010 0240	40,35	-	-	22 4010 0240	44,80	22 4510 0240	44,80	22 5010 0240	48,90	22 5510 0240	118,55
• 25,00	0.9843	22 2010 0250	42,15	-	-	22 3010 0250	45,45	-	-	22 4010 0250	52,45	22 4510 0250	52,45	22 5010 0250	55,55	22 5510 0250	125,20
• 26,00	1.0236	22 2010 0260	42,15	-	-	22 3010 0260	45,45	-	-	22 4010 0260	52,45	22 4510 0260	52,45	22 5010 0260	55,55	22 5510 0260	125,20
• 26,50	1.0433	22 2010 0265	42,15	-	-	22 3010 0265	45,45	-	-	22 4010 0265	52,45	22 4510 0265	52,45	22 5010 0265	55,55	22 5510 0265	125,20
• 27,00	1.0630	22 2010 0270	42,15	-	-	22 3010 0270	45,45	-	-	22 4010 0270	52,45	22 4510 0270	52,45	22 5010 0270	55,55	22 5510 0270	125,20
• 28,00	1.1024	22 2010 0280	42,15	-	-	22 3010 0280	45,45	-	-	22 4010 0280	52,45	22 4510 0280	52,45	22 5010 0280	55,55	22 5510 0280	125,20
• 29,00	1.1417	22 2010 0290	42,15	-	-	22 3010 0290	45,45	-	-	22 4010 0290	52,45	22 4510 0290	52,45	22 5010 0290	55,55	22 5510 0290	125,20
• 30,00	1.1811	22 2010 0300	42,15	-	-	22 3010 0300	45,45	-	-	22 4010 0300	52,45	22 4510 0300	52,45	22 5010 0300	55,55	22 5510 0300	125,20
• 31,00	1.2205	22 2010 0310	42,15	-	-	22 3010 0310	45,45	-	-	22 4010 0310	52,45	22 4510 0310	52,45	22 5010 0310	55,55	22 5510 0310	125,20
• 32,00	1.2598	22 2010 0320	42,15	-	-	22 3010 0320	45,45	-	-	22 4010 0320	52,45	22 4510 0320	52,45	22 5010 0320	55,55	22 5510 0320	125,20
• 33,00	1.2992	22 2010 0330	42,15	-	-	22 3010 0330	45,45	-	-	22 4010 0330	52,45	22 4510 0330	52,45	22 5010 0330	55,55	22 5510 0330	132,90
• 34,00	1.3386	22 2010 0340	42,15	-	-	22 3010 0340	45,45	-	-	22 4010 0340	52,45	22 4510 0340	52,45	22 5010 0340	55,55	22 5510 0340	132,90
• 35,00	1.3780	22 2010 0350	42,15	-	-	22 3010 0350	45,45	-	-	22 4010 0350	52,45	22 4510 0350	52,45	22 5010 0350	55,55	22 5510 0350	132,90



Bei Morsekonus 2+3 ist eine axiale Kühlung ohne Kühlmittelring möglich.
Hierzu muss das Gewinde des Kühlmittelringes (G) mit einer Schraube geschlossen werden.

With morse cone 2+3, axial cooling without coolant ring is possible.
For this, the thread of the coolant ring (G) must be closed with a screw.

Schraube für MK 2 / Screw for MT 2 = RC 1/16" **22 1030 0231 802 € 0,30**

Schraube für MK 3 / Screw for MT 3 = RC 1/8" **22 1030 0231 803 € 0,30**

Schnittdaten Cutting data	Film Movie
1302-1311	

MK 2+3 mit axialer Kühlung
MT 2+3 with axial cooling



MK 2,3,4,5 – Radiale Kühlung
mit Kühlmittelring
MT 2,3,4,5 – Radial coolant
with oil ring

Morsekegel
ISO 296 Typ BEK ·
Morse taper shank
ISO 296 type BEK



← ≈ 8×D →



Spiral genutet ·
Helical flute

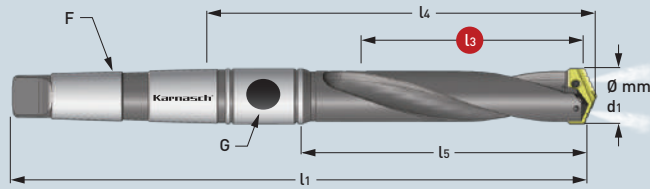

Art.	€	l3	l5	l4	l1	F	G	Art.	€
		Nutzlänge Max. drill depth	Körperlänge Body-length	Neue REF.- Länge REF.-length	Gesamtlänge Overall length	Morsekegel Morse taper	Gewinde Pipe tap		
		mm Zoll / Inch	mm Zoll / Inch	mm Zoll / Inch	mm Zoll / Inch				
• 22 1030 01111 0095 Ø 9,5-11,0 mm 0.3740-0.4331" OPTIMAL · OPTIMAL	151,30	111,1 mm 4.3740"	130,9 mm 5.1535"	167,4 mm 6.5905"	239,7 mm 9.4370"	2	1/16"	• 22 9002 01905	22,10
• 22 1030 01111 0115 Ø 11,5-12,5 mm 0.4528-0.4921" OPTIMAL · OPTIMAL	151,30	111,1 mm 4.3740"	130,9 mm 5.1535"	167,4 mm 6.5905"	239,7 mm 9.4370"	2	1/16"		
• 22 1030 01143 0130 Ø 13,0-17,5 mm 0.5118-0.6890" MÖGLICH · POSSIBLE Ø 13,0-15,0 mm 0.5118-0.5906" OPTIMAL · OPTIMAL	163,30	114,3 mm 4.5000"	135,0 mm 5.3150"	171,8 mm 6.7638"	243,7 mm 9.5945"	2	1/16"		
• 22 1030 01143 0155 Ø 15,5-17,5 mm 0.6102-0.6890" OPTIMAL · OPTIMAL	163,30	114,3 mm 4.5000"	135,0 mm 5.3150"	171,8 mm 6.7638"	243,7 mm 9.5945"	2	1/16"		
• 22 1030 02731 0180 Ø 18,0-24,0 mm 0.7087-0.9449" MÖGLICH · POSSIBLE Ø 18,0-21,0 mm 0.7087-0.8268" OPTIMAL · OPTIMAL	231,50	273,1 mm 10.7520"	301,6 mm 11.8740"	345,7 mm 13.6102"	435,8 mm 17.1575"	3	1/8"	• 22 9002 02540	24,85
• 22 1030 02731 0220 Ø 22,0-24,0 mm 0.8661-0.9449" OPTIMAL · OPTIMAL	231,50	273,1 mm 10.7520"	301,6 mm 11.8740"	345,7 mm 13.6102"	435,8 mm 17.1575"	3	1/8"		
• 22 1030 02890 0250 Ø 25,0-35,0 mm 0.9843-1.3780" MÖGLICH · POSSIBLE Ø 25,0-29,0 mm 0.9843-1.1417" OPTIMAL · OPTIMAL	286,70	289,0 mm 11.3780"	317,5 mm 12.5000"	363,6 mm 14.3150"	477,0 mm 18.7795"	4	1/8" Halter Holder 25,0-35,0 mm		
• 22 1030 02890 0300 Ø 30,0-35,0 mm 1.1811-1.3780" OPTIMAL · OPTIMAL	286,70	289,0 mm 11.3780"	317,5 mm 12.5000"	370,8 mm 14.5984"	484,2 mm 19.0630"	4	1/4" Halter Holder 30,0-35,0 mm	• 22 9002 03175	32,20

Ersatz-Torxschrauben und Schlüssel mit Drehmomentangabe
Spare Torx-screws and wrench with torque specification

Ø Diameter		TORX	€	max. Drehmoment / Torque (N/cm)	Schlüssel / Wrench	
mm	Zoll / Inch				€	
9,5-11,0	0.3740-0.4331	22 9010 0095	3,50	84	22 9011 0084	9,90
11,5-12,5	0.4528-0.4921	22 9010 0115	3,50	84		
13,0-17,5	0.5118-0.6890	22 9010 0130	3,50	175	22 9011 0175	9,90
18,0-24,0	0.7087-0.9449	22 9010 0180	3,50	305	22 9011 0305	10,90
25,0-35,0	0.9843-1.3780	22 9010 0250	3,60	690	22 9011 0690	11,70
36,0-65,0	1.4173-2.5591	22 9010 0360	3,65	1370	22 9011 1370	12,70
64,0-114,0	2.5197-4.4882	22 9010 0640	3,70	1750	22 9011 1750	18,70



PULVERSTAHL · POWDER STEEL						HARTMETALL · CARBIDE											
Ø mm d1	Ø Zoll / Inch d1	132°		144°		132°		144°		Guss/Cast iron 132°		132°		132°			
		Art.	€	Art.	€	Art.	€	Art.	€	Art.	€	Art.	€	Art.	€		
● 9,50	0.3740	22 2010 0095	24,85	-	-	22 3010 0095	26,05	-	-	22 4010 0095	29,30	22 4510 0095	29,30	22 5010 0095	30,45	22 5510 0095	66,40
○ 9,80	0.3858	-	-	-	-	-	-	-	-	-	-	-	-	-	-	-	-
● 10,00	0.3937	22 2010 0100	24,85	-	-	22 3010 0100	26,05	-	-	22 4010 0100	29,30	22 4510 0100	29,30	22 5010 0100	30,45	22 5510 0100	66,40
● 10,20	0.4016	22 2010 0102	24,85	-	-	22 3010 0102	26,05	-	-	22 4010 0102	29,30	22 4510 0102	29,30	22 5010 0102	30,45	22 5510 0102	66,40
● 10,50	0.4134	22 2010 0105	24,85	-	-	22 3010 0105	26,05	-	-	22 4010 0105	29,30	22 4510 0105	29,30	22 5010 0105	30,45	22 5510 0105	66,40
● 10,80	0.4252	22 2010 0108	24,85	-	-	22 3010 0108	26,05	-	-	22 4010 0108	29,30	22 4510 0108	29,30	22 5010 0108	30,45	22 5510 0108	66,40
● 11,00	0.4331	22 2010 0110	24,85	-	-	22 3010 0110	26,05	-	-	22 4010 0110	29,30	22 4510 0110	29,30	22 5010 0110	30,45	22 5510 0110	66,40
● 11,50	0.4528	22 2010 0115	24,85	-	-	22 3010 0115	26,05	-	-	22 4010 0115	29,30	22 4510 0115	29,30	22 5010 0115	30,45	22 5510 0115	66,40
● 12,00	0.4724	22 2010 0120	24,85	-	-	22 3010 0120	26,05	-	-	22 4010 0120	29,30	22 4510 0120	29,30	22 5010 0120	30,45	22 5510 0120	66,40
● 12,50	0.4921	22 2010 0125	24,85	-	-	22 3010 0125	26,05	-	-	22 4010 0125	29,30	22 4510 0125	29,30	22 5010 0125	30,45	22 5510 0125	66,40
● 13,00	0.5118	22 2010 0130	28,30	-	-	22 3010 0130	28,95	-	-	22 4010 0130	34,45	22 4510 0130	34,45	22 5010 0130	35,10	22 5510 0130	92,70
● 13,50	0.5315	22 2010 0135	28,30	-	-	22 3010 0135	28,95	-	-	22 4010 0135	34,45	22 4510 0135	34,45	22 5010 0135	35,10	22 5510 0135	92,70
● 14,00	0.5512	22 2010 0140	28,30	-	-	22 3010 0140	28,95	-	-	22 4010 0140	34,45	22 4510 0140	34,45	22 5010 0140	35,10	22 5510 0140	92,70
● 14,50	0.5709	22 2010 0145	28,30	-	-	22 3010 0145	28,95	-	-	22 4010 0145	34,45	22 4510 0145	34,45	22 5010 0145	35,10	22 5510 0145	92,70
● 15,00	0.5906	22 2010 0150	28,30	-	-	22 3010 0150	28,95	-	-	22 4010 0150	34,45	22 4510 0150	34,45	22 5010 0150	35,10	22 5510 0150	92,70
● 15,50	0.6102	22 2010 0155	28,30	-	-	22 3010 0155	28,95	-	-	22 4010 0155	34,45	22 4510 0155	34,45	22 5010 0155	35,10	22 5510 0155	92,70
● 16,00	0.6299	22 2010 0160	28,30	-	-	22 3010 0160	28,95	-	-	22 4010 0160	34,45	22 4510 0160	34,45	22 5010 0160	35,10	22 5510 0160	92,70
● 16,50	0.6496	22 2010 0165	28,30	-	-	22 3010 0165	28,95	-	-	22 4010 0165	34,45	22 4510 0165	34,45	22 5010 0165	35,10	22 5510 0165	92,70
● 17,00	0.6693	22 2010 0170	28,30	-	-	22 3010 0170	28,95	-	-	22 4010 0170	34,45	22 4510 0170	34,45	22 5010 0170	35,10	22 5510 0170	92,70
● 17,50	0.6890	22 2010 0175	28,30	-	-	22 3010 0175	28,95	-	-	22 4010 0175	34,45	22 4510 0175	34,45	22 5010 0175	35,10	22 5510 0175	92,70
● 18,00	0.7087	22 2010 0180	36,00	-	-	22 3010 0180	40,35	-	-	22 4010 0180	44,80	22 4510 0180	44,80	22 5010 0180	48,90	22 5510 0180	102,55
● 18,50	0.7283	22 2010 0185	36,00	-	-	22 3010 0185	40,35	-	-	22 4010 0185	44,80	22 4510 0185	44,80	22 5010 0185	48,90	22 5510 0185	102,55
● 19,00	0.7480	22 2010 0190	36,00	-	-	22 3010 0190	40,35	-	-	22 4010 0190	44,80	22 4510 0190	44,80	22 5010 0190	48,90	22 5510 0190	102,55
● 19,50	0.7677	22 2010 0195	36,00	-	-	22 3010 0195	40,35	-	-	22 4010 0195	44,80	22 4510 0195	44,80	22 5010 0195	48,90	22 5510 0195	102,55
● 20,00	0.7874	22 2010 0200	36,00	-	-	22 3010 0200	40,35	-	-	22 4010 0200	44,80	22 4510 0200	44,80	22 5010 0200	48,90	22 5510 0200	102,55
● 20,50	0.8071	22 2010 0205	36,00	-	-	22 3010 0205	40,35	-	-	22 4010 0205	44,80	22 4510 0205	44,80	22 5010 0205	48,90	22 5510 0205	118,55
● 21,00	0.8268	22 2010 0210	36,00	-	-	22 3010 0210	40,35	-	-	22 4010 0210	44,80	22 4510 0210	44,80	22 5010 0210	48,90	22 5510 0210	118,55
● 22,00	0.8661	22 2010 0220	36,00	-	-	22 3010 0220	40,35	-	-	22 4010 0220	44,80	22 4510 0220	44,80	22 5010 0220	48,90	22 5510 0220	118,55
● 23,00	0.9055	22 2010 0230	36,00	-	-	22 3010 0230	40,35	-	-	22 4010 0230	44,80	22 4510 0230	44,80	22 5010 0230	48,90	22 5510 0230	118,55
● 24,00	0.9449	22 2010 0240	36,00	-	-	22 3010 0240	40,35	-	-	22 4010 0240	44,80	22 4510 0240	44,80	22 5010 0240	48,90	22 5510 0240	118,55
● 25,00	0.9843	22 2010 0250	42,15	-	-	22 3010 0250	45,45	-	-	22 4010 0250	52,45	22 4510 0250	52,45	22 5010 0250	55,55	22 5510 0250	125,20
● 26,00	1.0236	22 2010 0260	42,15	-	-	22 3010 0260	45,45	-	-	22 4010 0260	52,45	22 4510 0260	52,45	22 5010 0260	55,55	22 5510 0260	125,20
● 26,50	1.0433	22 2010 0265	42,15	-	-	22 3010 0265	45,45	-	-	22 4010 0265	52,45	22 4510 0265	52,45	22 5010 0265	55,55	22 5510 0265	125,20
● 27,00	1.0630	22 2010 0270	42,15	-	-	22 3010 0270	45,45	-	-	22 4010 0270	52,45	22 4510 0270	52,45	22 5010 0270	55,55	22 5510 0270	125,20
● 28,00	1.1024	22 2010 0280	42,15	-	-	22 3010 0280	45,45	-	-	22 4010 0280	52,45	22 4510 0280	52,45	22 5010 0280	55,55	22 5510 0280	125,20
● 29,00	1.1417	22 2010 0290	42,15	-	-	22 3010 0290	45,45	-	-	22 4010 0290	52,45	22 4510 0290	52,45	22 5010 0290	55,55	22 5510 0290	125,20
● 30,00	1.1811	22 2010 0300	42,15	-	-	22 3010 0300	45,45	-	-	22 4010 0300	52,45	22 4510 0300	52,45	22 5010 0300	55,55	22 5510 0300	125,20
● 31,00	1.2205	22 2010 0310	42,15	-	-	22 3010 0310	45,45	-	-	22 4010 0310	52,45	22 4510 0310	52,45	22 5010 0310	55,55	22 5510 0310	125,20
● 32,00	1.2598	22 2010 0320	42,15	-	-	22 3010 0320	45,45	-	-	22 4010 0320	52,45	22 4510 0320	52,45	22 5010 0320	55,55	22 5510 0320	125,20
● 33,00	1.2992	22 2010 0330	42,15	-	-	22 3010 0330	45,45	-	-	22 4010 0330	52,45	22 4510 0330	52,45	22 5010 0330	55,55	22 5510 0330	132,90
● 34,00	1.3386	22 2010 0340	42,15	-	-	22 3010 0340	45,45	-	-	22 4010 0340	52,45	22 4510 0340	52,45	22 5010 0340	55,55	22 5510 0340	132,90
● 35,00	1.3780	22 2010 0350	42,15	-	-	22 3010 0350	45,45	-	-	22 4010 0350	52,45	22 4510 0350	52,45	22 5010 0350	55,55	22 5510 0350	132,90
● 36,00	1.4173	22 2010 0360	57,75	-	-	22 3010 0360	59,50	-	-	-	-	-	-	-	-	-	-
● 37,00	1.4567	22 2010 0370	57,75	-	-	22 3010 0370	59,50	-	-	-	-	-	-	-	-	-	-
● 38,00	1.4961	22 2010 0380	57,75	-	-	22 3010 0380	59,50	-	-	-	-	-	-	-	-	-	-
● 39,00	1.5354	22 2010 0390	57,75	-	-	22 3010 0390	59,50	-	-	-	-	-	-	-	-	-	-
● 40,00	1.5748	22 2010 0400	57,75	-	-	22 3010 0400	59,50	-	-	-	-	-	-	-	-	-	-
● 41,00	1.6142	22 2010 0410	57,75	-	-	22 3010 0410	59,50	-	-	-	-	-	-	-	-	-	-
● 42,00	1.6535	22 2010 0420	57,75	-	-	22 3010 0420	59,50	-	-	-	-	-	-	-	-	-	-
● 43,00	1.6929	22 2010 0430	57,75	-	-	22 3010 0430	59,50	-	-	-	-	-	-	-	-	-	-
● 44,00	1.7323	22 2010 0440	57,75	-	-	22 3010 0440	59,50	-	-	-	-	-	-	-	-	-	-
● 45,00	1.7717	22 2010 0450	57,75	-	-	22 3010 0450	59,50	-	-	-	-	-	-	-	-	-	-
● 46,00	1.8110	22 2010 0460	57,75	-	-	22 3010 0460	59,50	-	-	-	-	-	-	-	-	-	-
● 47,00	1.8504	22 2010 0470	57,75	-	-	22 3010 0470	59,50	-	-	-	-	-	-	-	-	-	-

Fortsetzung Seite 340 · Continued page 340

MK 2+3 mit axialer Kühlung
MT 2+3 with axial cooling



MK 2,3,4,5 – Radiale Kühlung
mit Kühlmittelring
MT 2,3,4,5 – Radial coolant
with oil ring

Morsekegel
ISO 296 Typ BEK ·
Morse taper shank
ISO 296 type BEK

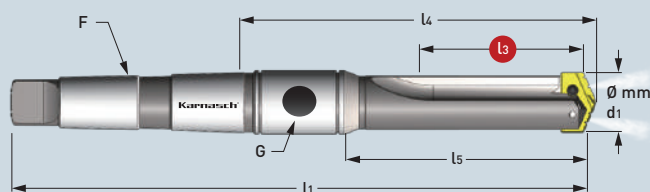

~ 3xD
Mittel · Intermediate

Gerade genutet ·
Straight flute

Art.	€	l3		l5		l4		l1		F	G	Art.	€
		mm Zoll / Inch	mm Zoll / Inch	mm Zoll / Inch	mm Zoll / Inch	mm Zoll / Inch	mm Zoll / Inch	Morsekegel Morse taper	Gewinde Pipe tap				
• 22 1040 00318 0095 Ø 9,5-11,0 mm 0.3740-0.4331" OPTIMAL · OPTIMAL	118,80	31,8 mm 1.2520"	51,5 mm 2.0276"	88,0 mm 3.4646"	160,3 mm 6.3110"	2	1/16"					• 22 9002 01905	22,10
• 22 1040 00318 0115 Ø 11,5-12,5 mm 0.4528-0.4921" OPTIMAL · OPTIMAL	118,80	31,8 mm 1.2520"	51,5 mm 2.0276"	88,0 mm 3.4646"	160,3 mm 6.3110"	2	1/16"						
• 22 1040 00350 0130 Ø 13,0-17,5 mm 0.5118-0.6890" MÖGLICH · POSSIBLE Ø 13,0-15,0 mm 0.5118-0.5906" OPTIMAL · OPTIMAL	128,20	35,0 mm 1.3780"	55,5 mm 2.1850"	92,4 mm 3.6378"	164,3 mm 6.4685"	2	1/16"						
• 22 1040 00350 0155 Ø 15,5-17,5 mm 0.6102-0.6890" OPTIMAL · OPTIMAL	128,20	35,0 mm 1.3780"	55,5 mm 2.1850"	92,4 mm 3.6378"	164,3 mm 6.4685"	2	1/16"						
• 22 1040 00698 0180 Ø 18,0-24,0 mm 0.7087-0.9449" MÖGLICH · POSSIBLE Ø 18,0-21,0 mm 0.7087-0.8268" OPTIMAL · OPTIMAL	141,20	69,8 mm 2.7480"	98,4 mm 3.8740"	142,5 mm 5.6102"	232,5 mm 9.1535"	3	1/8"					• 22 9002 02540	24,85
• 22 1040 00698 0220 Ø 22,0-24,0 mm 0.8661-0.9449" OPTIMAL · OPTIMAL	141,20	69,8 mm 2.7480"	98,4 mm 3.8740"	142,5 mm 5.6102"	232,5 mm 9.1535"	3	1/8"						
• 22 1040 00857 0250 Ø 25,0-35,0 mm 0.9843-1.3780" MÖGLICH · POSSIBLE Ø 25,0-29,0 mm 0.9843-1.1417" OPTIMAL · OPTIMAL	166,90	85,7 mm 3.3740"	114,3 mm 4.5000"	160,4 mm 6.3150"	273,8 mm 10.7795"	4	1/8" Halter Holder 25,0-35,0 mm						
• 22 1040 00857 0300 Ø 30,0-35,0 mm 1.1811-1.3780" OPTIMAL · OPTIMAL	166,90	85,7 mm 3.3740"	114,3 mm 4.5000"	167,6 mm 6.5984"	281,0 mm 11.0630"	4	1/4" Halter Holder 30,0-35,0 mm					• 22 9002 03175	32,20
• 22 1040 01206 0360 Ø 36,0-47,0 mm 1.4173-1.8504" MÖGLICH · POSSIBLE Ø 36,0-41,0 mm 1.4173-1.6142" OPTIMAL · OPTIMAL	224,25	120,6 mm 4.7480"	152,4 mm 6.0000"	206,4 mm 8.1259"	319,1 mm 12.5630"	4	1/4"						
• 22 1040 01206 0420 Ø 42,0-47,0 mm 1.6535-1.8504" OPTIMAL · OPTIMAL	224,25	120,6 mm 4.7480"	152,4 mm 6.0000"	206,4 mm 8.1259"	319,1 mm 12.5630"	4	1/4"						

Fortsetzung Seite 341 · Continued page 341

Schnittdaten
Cutting data

Film
Movie



1302-1311

339





PULVERSTAHL · POWDER STEEL										HARTMETALL · CARBIDE									
Ø mm d1		Ø Zoll / Inch d1		22 2010 Pulverstahl 25 STEEL-TEC beschichtet Für Edelstahl, Stahl, Guss Powder steel 25 STEEL-TEC coated For stainless steel, steel, cast iron		22 2510 Pulverstahl 15 STEEL-TEC beschichtet Für legierte Stähle, Edelstahl, Stahl, Guss Powder steel 15 STEEL-TEC coated For alloy steel, stainless steel, steel, cast iron		22 3010 Pulverstahl 25 ALU-TEC beschichtet Für Alu, Messing, Kupfer Powder steel 25 ALU-TEC coated For alu, brass, copper		22 3510 Pulverstahl 15 ALU-TEC beschichtet Für Alu, Messing, Kupfer Powder steel 15 ALU-TEC coated For alloy steel, steel, cast iron		22 4010 Hartmetall 20/30 STEEL-TEC beschichtet Für Edelstahl, hochfester Stahl, gehärteter Stahl Carbide 20/30 STEEL-TEC coated For stainless steel, high strength alloys, hardened steel		22 4510 Hartmetall 20/30 STEEL-TEC beschichtet Für alle Gussarten Carbide 20/30 STEEL-TEC coated For all kinds of cast iron		22 5010 Hartmetall 20/30 ALU-TEC beschichtet Für Alu, Messing, Kupfer Carbide 20/30 ALU-TEC coated For alu, brass, copper		22 5510 Hartmetall 20/30 DIA-TEC beschichtet Für abrasive Materialien wie: GFK, CFK, Graphit Carbide 20/30 DIA-TEC coated For abrasive materials such as: fiberglass, carbon fiber, graphite	
48,00	1.8898	22 2010 0480	82,65	-	-	22 3010 0480	82,65	-	-	-	-	-	-	-	-	-	-	-	
49,00	1.9291	22 2010 0490	82,65	-	-	22 3010 0490	82,65	-	-	-	-	-	-	-	-	-	-	-	
50,00	1.9685	22 2010 0500	82,65	-	-	22 3010 0500	82,65	-	-	-	-	-	-	-	-	-	-	-	
51,00	2.0079	22 2010 0510	82,65	-	-	22 3010 0510	82,65	-	-	-	-	-	-	-	-	-	-	-	
52,00	2.0472	22 2010 0520	82,65	-	-	22 3010 0520	82,65	-	-	-	-	-	-	-	-	-	-	-	
53,00	2.0866	22 2010 0530	82,65	-	-	22 3010 0530	82,65	-	-	-	-	-	-	-	-	-	-	-	
54,00	2.1260	22 2010 0540	82,65	-	-	22 3010 0540	82,65	-	-	-	-	-	-	-	-	-	-	-	
55,00	2.1654	22 2010 0550	82,65	-	-	22 3010 0550	82,65	-	-	-	-	-	-	-	-	-	-	-	
56,00	2.2047	22 2010 0560	82,65	-	-	22 3010 0560	82,65	-	-	-	-	-	-	-	-	-	-	-	
57,00	2.2441	22 2010 0570	82,65	-	-	22 3010 0570	82,65	-	-	-	-	-	-	-	-	-	-	-	
58,00	2.2835	22 2010 0580	82,65	-	-	22 3010 0580	82,65	-	-	-	-	-	-	-	-	-	-	-	
59,00	2.3228	22 2010 0590	82,65	-	-	22 3010 0590	82,65	-	-	-	-	-	-	-	-	-	-	-	
60,00	2.3622	22 2010 0600	82,65	-	-	22 3010 0600	82,65	-	-	-	-	-	-	-	-	-	-	-	
61,00	2.4016	22 2010 0610	82,65	-	-	22 3010 0610	82,65	-	-	-	-	-	-	-	-	-	-	-	
62,00	2.4409	22 2010 0620	82,65	-	-	22 3010 0620	82,65	-	-	-	-	-	-	-	-	-	-	-	
63,00	2.4803	22 2010 0630	82,65	-	-	22 3010 0630	82,65	-	-	-	-	-	-	-	-	-	-	-	
64,00	2.5197	22 2010 0640	82,65	-	-	22 3010 0640	82,65	-	-	-	-	-	-	-	-	-	-	-	
65,00	2.5591	22 2010 0650	82,65	-	-	22 3010 0650	82,65	-	-	-	-	-	-	-	-	-	-	-	
64,00	2.5197	-	-	22 2510 0640	103,90	-	-	22 3510 0640	97,15	-	-	-	-	-	-	-	-	-	
66,00	2.5984	-	-	22 2510 0660	103,90	-	-	22 3510 0660	97,15	-	-	-	-	-	-	-	-	-	
68,00	2.6772	-	-	22 2510 0680	103,90	-	-	22 3510 0680	97,15	-	-	-	-	-	-	-	-	-	
70,00	2.7559	-	-	22 2510 0700	103,90	-	-	22 3510 0700	97,15	-	-	-	-	-	-	-	-	-	
72,00	2.8346	-	-	22 2510 0720	103,90	-	-	22 3510 0720	97,15	-	-	-	-	-	-	-	-	-	
74,00	2.9134	-	-	22 2510 0740	103,90	-	-	22 3510 0740	97,15	-	-	-	-	-	-	-	-	-	
76,00	2.9921	-	-	22 2510 0760	103,90	-	-	22 3510 0760	97,15	-	-	-	-	-	-	-	-	-	
78,00	3.0709	-	-	22 2510 0780	114,75	-	-	22 3510 0780	108,00	-	-	-	-	-	-	-	-	-	
80,00	3.1496	-	-	22 2510 0800	114,75	-	-	22 3510 0800	108,00	-	-	-	-	-	-	-	-	-	
82,00	3.2283	-	-	22 2510 0820	114,75	-	-	22 3510 0820	108,00	-	-	-	-	-	-	-	-	-	
84,00	3.3071	-	-	22 2510 0840	114,75	-	-	22 3510 0840	108,00	-	-	-	-	-	-	-	-	-	
86,00	3.3858	-	-	22 2510 0860	114,75	-	-	22 3510 0860	108,00	-	-	-	-	-	-	-	-	-	
88,00	3.4646	-	-	22 2510 0880	114,75	-	-	22 3510 0880	108,00	-	-	-	-	-	-	-	-	-	
90,00	3.5433	-	-	22 2510 0900	134,70	-	-	22 3510 0900	127,85	-	-	-	-	-	-	-	-	-	
92,00	3.6220	-	-	22 2510 0920	134,70	-	-	22 3510 0920	127,85	-	-	-	-	-	-	-	-	-	
94,00	3.7008	-	-	22 2510 0940	134,70	-	-	22 3510 0940	127,85	-	-	-	-	-	-	-	-	-	
96,00	3.7795	-	-	22 2510 0960	134,70	-	-	22 3510 0960	127,85	-	-	-	-	-	-	-	-	-	
98,00	3.8583	-	-	22 2510 0980	134,70	-	-	22 3510 0980	127,85	-	-	-	-	-	-	-	-	-	
100,00	3.9370	-	-	22 2510 1000	134,70	-	-	22 3510 1000	127,85	-	-	-	-	-	-	-	-	-	
102,00	4.0157	-	-	22 2510 1020	153,50	-	-	22 3510 1020	146,65	-	-	-	-	-	-	-	-	-	
104,00	4.0945	-	-	22 2510 1040	153,50	-	-	22 3510 1040	146,65	-	-	-	-	-	-	-	-	-	
106,00	4.1732	-	-	22 2510 1060	153,50	-	-	22 3510 1060	146,65	-	-	-	-	-	-	-	-	-	
108,00	4.2520	-	-	22 2510 1080	153,50	-	-	22 3510 1080	146,65	-	-	-	-	-	-	-	-	-	
110,00	4.3307	-	-	22 2510 1100	153,50	-	-	22 3510 1100	146,65	-	-	-	-	-	-	-	-	-	
112,00	4.4094	-	-	22 2510 1120	153,50	-	-	22 3510 1120	146,65	-	-	-	-	-	-	-	-	-	
114,00	4.4882	-	-	22 2510 1140	153,50	-	-	22 3510 1140	146,65	-	-	-	-	-	-	-	-	-	



Bei Morsekonus 2+3 ist eine axiale Kühlung ohne Kühlmittlering möglich.
Hierzu muss das Gewinde des Kühlmittleringes (G) mit einer Schraube geschlossen werden.

With morse cone 2+3, axial cooling without coolant ring is possible.
For this, the thread of the coolant ring (G) must be closed with a screw.

Schraube für MK 2 / Screw for MT 2 = RC 1/16"		22 1030 0231 802	€ 0,30
Schraube für MK 3 / Screw for MT 3 = RC 1/8"		22 1030 0231 803	€ 0,30

Schnittdaten
Cutting data

Film
Movie

1302-1311

MK 2+3 mit axialer Kühlung
MT 2+3 with axial cooling



MK 2,3,4,5 – Radiale Kühlung
mit Kühlmittelring
MT 2,3,4,5 – Radial coolant
with oil ring

Morsekegel
ISO 296 Typ BEK ·
Morse taper shank
ISO 296 type BEK

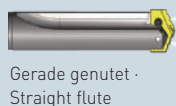
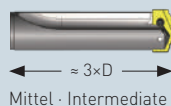
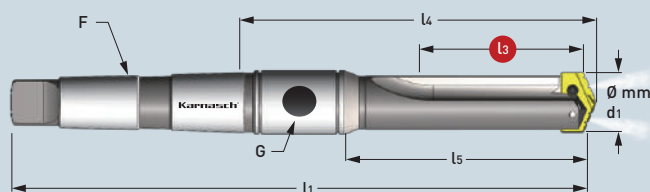

Art.	€	mm Zoll / Inch	mm Zoll / Inch	mm Zoll / Inch	mm Zoll / Inch			Art.	€	
• 22 1040 01301 0480	256,10	Ø 48,0-65,0 mm 1.8898-2.5591" Ø 48,0-55,0 mm 1.8898-2.1654"	130,1 mm 5.1220"	165,1 mm 6.5000"	219,1 mm 8.6260"	363,5 mm 14.3110"	5	1/4"	• 22 9002 04445	42,30
• 22 1040 01301 0560	256,10	Ø 56,0-65,0 mm 2.2047-2.5591"	130,1 mm 5.1220"	165,1 mm 6.5000"	219,1 mm 8.6260"	363,5 mm 14.3110"	5	1/4"		
• 22 1040 01715 0640	399,15	Ø 64,0-88,0 mm 2.5197-3.4646" Ø 64,0-76,0 mm 2.5197-2.9921"	171,5 mm 6.7519"	215,9 mm 8.5000"	287,3 mm 11.3110"	430,2 mm 16.9370"	5	1/2"	• 22 9002 05715	58,25
• 22 1040 01715 0780	399,15	Ø 78,0-88,0 mm 3.0709-3.4646"	171,5 mm 6.7519"	215,9 mm 8.5000"	287,3 mm 11.3110"	430,2 mm 16.9370"	5	1/2"		
• 22 1040 01715 0900	539,35	Ø 90,0-114,0 mm 3.5433-4.4882" Ø 90,0-100,0 mm 3.5433-3.9370"	171,5 mm 6.7519"	225,4 mm 8.8740"	296,8 mm 11.6850"	439,7 mm 17.3110"	5	1/2"		
• 22 1040 01715 1020	539,35	Ø 102,0-114,0 mm 4.0157-4.4882"	171,5 mm 6.7519"	225,4 mm 8.8740"	296,8 mm 11.6850"	439,7 mm 17.3110"	5	1/2"		

Halter werden **ohne** Einsätze, inklusive 2x TORX Befestigungsschrauben und 1x TORX Schlüssel geliefert.
Holders are delivered **without** inserts including 2x TORX-screws and 1x TORX wrench.

Für Maschinen ohne axiale/radiale Kühlmittelzufuhr kann ein Kühlmittelring auf den Halter montiert werden. Details siehe Seite 356
For machines without radial/axial coolant supply a oil ring can be mounted on the holder. Details see page 356



Ersatz-Torxschrauben und Schlüssel mit Drehmomentangabe
Spare Torx-screws and wrench with torque specification

Ø Diameter		TORX	max. Drehmoment / Torque (N/cm)		Schlüssel / Wrench	
mm	Zoll / Inch		€			€
9,5-11,0	0.3740-0.4331	22 9010 0095	3,50	84	22 9011 0084	9,90
11,5-12,5	0.4528-0.4921	22 9010 0115	3,50	84	22 9011 0175	9,90
13,0-17,5	0.5118-0.6890	22 9010 0130	3,50	175	22 9011 0305	10,90
18,0-24,0	0.7087-0.9449	22 9010 0180	3,50	305	22 9011 0690	11,70
25,0-35,0	0.9843-1.3780	22 9010 0250	3,60	690	22 9011 1370	12,70
36,0-65,0	1.4173-2.5591	22 9010 0360	3,65	1370	22 9011 1750	18,70
64,0-114,0	2.5197-4.4882	22 9010 0640	3,70	1750		





PULVERSTAHL · POWDER STEEL										HARTMETALL · CARBIDE									
Ø mm d1		Ø Zoll / Inch d1		22 2010		22 2510		22 3010		22 3510		22 4010		22 4510		22 5010		22 5510	
				Pulverstahl 25 STEEL-TEC beschichtet Für Edelstahl, Stahl, Guss		Pulverstahl 15 STEEL-TEC beschichtet Für legierte Stähle, Edelstahl, Stahl, Guss		Pulverstahl 25 ALU-TEC beschichtet Für Alu, Messing, Kupfer		Pulverstahl 15 ALU-TEC beschichtet Für Alu, Messing, Kupfer		Hartmetall 20/30 STEEL-TEC beschichtet Für Edelstahl, hochfester Stahl, gehärteter Stahl		Hartmetall 20/30 STEEL-TEC beschichtet Für alle Gussarten		Hartmetall 20/30 ALU-TEC beschichtet Für Alu, Messing, Kupfer		Hartmetall 20/30 DIA-TEC beschichtet Für abrasive Materialien wie: GFK, CFK, Graphit	
				Powder steel 25 STEEL-TEC coated For stainless steel, steel, cast iron		Powder steel 15 STEEL-TEC coated For alloy steel, stainless steel, steel, cast iron		Powder steel 25 ALU-TEC coated For alu, brass, copper		Powder steel 15 ALU-TEC coated For alloy steel, steel, cast iron		Carbide 20/30 STEEL-TEC coated For stainless steel, high strength alloys, hardened steel		Carbide 20/30 STEEL-TEC coated For all kinds of cast iron		Carbide 20/30 ALU-TEC coated For alu, brass, copper		Carbide 20/30 DIA-TEC coated For abrasive materials such as: fiberglass, carbon fiber, graphite	
Art.	€	Art.	€	Art.	€	Art.	€	Art.	€	Art.	€	Art.	€	Art.	€	Art.	€	Art.	€
• 36,00	1.4173	22 2010 0360	57,75	-	-	22 3010 0360	59,50	-	-	-	-	-	-	-	-	-	-	-	-
• 37,00	1.4567	22 2010 0370	57,75	-	-	22 3010 0370	59,50	-	-	-	-	-	-	-	-	-	-	-	-
• 38,00	1.4961	22 2010 0380	57,75	-	-	22 3010 0380	59,50	-	-	-	-	-	-	-	-	-	-	-	-
• 39,00	1.5354	22 2010 0390	57,75	-	-	22 3010 0390	59,50	-	-	-	-	-	-	-	-	-	-	-	-
• 40,00	1.5748	22 2010 0400	57,75	-	-	22 3010 0400	59,50	-	-	-	-	-	-	-	-	-	-	-	-
• 41,00	1.6142	22 2010 0410	57,75	-	-	22 3010 0410	59,50	-	-	-	-	-	-	-	-	-	-	-	-
• 42,00	1.6535	22 2010 0420	57,75	-	-	22 3010 0420	59,50	-	-	-	-	-	-	-	-	-	-	-	-
• 43,00	1.6929	22 2010 0430	57,75	-	-	22 3010 0430	59,50	-	-	-	-	-	-	-	-	-	-	-	-
• 44,00	1.7323	22 2010 0440	57,75	-	-	22 3010 0440	59,50	-	-	-	-	-	-	-	-	-	-	-	-
• 45,00	1.7717	22 2010 0450	57,75	-	-	22 3010 0450	59,50	-	-	-	-	-	-	-	-	-	-	-	-
• 46,00	1.8110	22 2010 0460	57,75	-	-	22 3010 0460	59,50	-	-	-	-	-	-	-	-	-	-	-	-
• 47,00	1.8504	22 2010 0470	57,75	-	-	22 3010 0470	59,50	-	-	-	-	-	-	-	-	-	-	-	-
• 48,00	1.8898	22 2010 0480	82,65	-	-	22 3010 0480	82,65	-	-	-	-	-	-	-	-	-	-	-	-
• 49,00	1.9291	22 2010 0490	82,65	-	-	22 3010 0490	82,65	-	-	-	-	-	-	-	-	-	-	-	-
• 50,00	1.9685	22 2010 0500	82,65	-	-	22 3010 0500	82,65	-	-	-	-	-	-	-	-	-	-	-	-
• 51,00	2.0079	22 2010 0510	82,65	-	-	22 3010 0510	82,65	-	-	-	-	-	-	-	-	-	-	-	-
• 52,00	2.0472	22 2010 0520	82,65	-	-	22 3010 0520	82,65	-	-	-	-	-	-	-	-	-	-	-	-
• 53,00	2.0866	22 2010 0530	82,65	-	-	22 3010 0530	82,65	-	-	-	-	-	-	-	-	-	-	-	-
• 54,00	2.1260	22 2010 0540	82,65	-	-	22 3010 0540	82,65	-	-	-	-	-	-	-	-	-	-	-	-
• 55,00	2.1654	22 2010 0550	82,65	-	-	22 3010 0550	82,65	-	-	-	-	-	-	-	-	-	-	-	-
• 56,00	2.2047	22 2010 0560	82,65	-	-	22 3010 0560	82,65	-	-	-	-	-	-	-	-	-	-	-	-
• 57,00	2.2441	22 2010 0570	82,65	-	-	22 3010 0570	82,65	-	-	-	-	-	-	-	-	-	-	-	-
• 58,00	2.2835	22 2010 0580	82,65	-	-	22 3010 0580	82,65	-	-	-	-	-	-	-	-	-	-	-	-
• 59,00	2.3228	22 2010 0590	82,65	-	-	22 3010 0590	82,65	-	-	-	-	-	-	-	-	-	-	-	-
• 60,00	2.3622	22 2010 0600	82,65	-	-	22 3010 0600	82,65	-	-	-	-	-	-	-	-	-	-	-	-
• 61,00	2.4016	22 2010 0610	82,65	-	-	22 3010 0610	82,65	-	-	-	-	-	-	-	-	-	-	-	-
• 62,00	2.4409	22 2010 0620	82,65	-	-	22 3010 0620	82,65	-	-	-	-	-	-	-	-	-	-	-	-
• 63,00	2.4803	22 2010 0630	82,65	-	-	22 3010 0630	82,65	-	-	-	-	-	-	-	-	-	-	-	-
• 64,00	2.5197	22 2010 0640	82,65	-	-	22 3010 0640	82,65	-	-	-	-	-	-	-	-	-	-	-	-
• 65,00	2.5591	22 2010 0650	82,65	-	-	22 3010 0650	82,65	-	-	-	-	-	-	-	-	-	-	-	-

Fortsetzung Seite 344 · Continued page 344

MK 2+3 mit axialer Kühlung
MT 2+3 with axial cooling

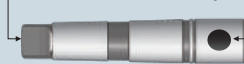

MK 2,3,4,5 – Radiale Kühlung
mit Kühlmittelring
MT 2,3,4,5 – Radial coolant
with oil ring

Morsekegel
ISO 296 Typ BEK ·
Morse taper shank
ISO 296 type BEK

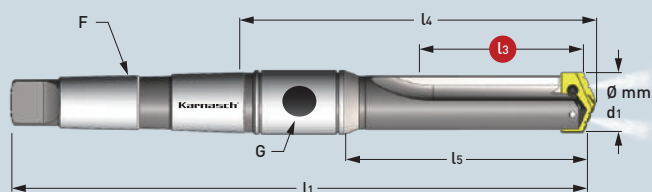

~ 8xD
Mittel · Intermediate

Gerade genutet ·
Straight flute

Art.	€	mm Zoll / Inch	mm Zoll / Inch	mm Zoll / Inch	mm Zoll / Inch	F	G	Art.	€
		Max. drill depth	Body-length	Neue REF.-Länge	Gesamtlänge	Morsekegel	Gewinde		
				REF.-length	Overall length	Morse taper	Pipe tap	Oil ring	
• 22 1040 03493 0360	437,00							• 22 9002 03175	32,20
Ø 36,0-47,0 mm 1.4173-1.8504"									
Ø 36,0-41,0 mm 1.4173-1.6142"									
• 22 1040 03493 0420	437,00	349,3 mm 13.7520"	381,0 mm 15.0000"	435,0 mm 17.1260"	547,7 mm 21.5630"	4	1/4"		
Ø 42,0-47,0 mm 1.6535-1.8504"									
• 22 1040 04223 0480	559,70	422,3 mm 16.6260"	457,2 mm 18.0000"	511,2 mm 20.1260"	655,6 mm 25.8110"	5	1/4"	• 22 9002 04445	42,30
Ø 48,0-65,0 mm 1.8898-2.5591"									
Ø 48,0-55,0 mm 1.8898-2.1654"									
• 22 1040 04223 0560	559,70	422,3 mm 16.6260"	457,2 mm 18.0000"	511,2 mm 20.1260"	655,6 mm 25.8110"	5	1/4"		
Ø 56,0-65,0 mm 2.2047-2.5591"									

Fortsetzung Seite 345 · Continued page 345

MK 2+3 mit axialer Kühlung
MT 2+3 with axial cooling



Bei Morsekonus 2+3 ist eine axiale Kühlung ohne Kühlmittelring möglich.
Hierzu muss das Gewinde des Kühlmittelringes (G) mit einer Schraube geschlossen werden.

With morse cone 2+3, axial cooling without coolant ring is possible.
For this, the thread of the coolant ring (G) must be closed with a screw.

Schraube für MK 2 / Screw for MT 2 = RC 1/16" **22 1030 0231 802 € 0,30**

Schraube für MK 3 / Screw for MT 3 = RC 1/8" **22 1030 0231 803 € 0,30**

Schnittdaten
Cutting data

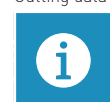

1302-1311

Film
Movie



343





PULVERSTAHL · POWDER STEEL

HARTMETALL · CARBIDE

Ø mm d1	Ø Zoll / Inch d1	22 2010		22 2510		22 3010		22 3510		22 4010		22 4510		22 5010		22 5510	
		Art.	€	Art.	€	Art.	€	Art.	€	Art.	€	Art.	€	Art.	€	Art.	€
• 64,00	2.5197	-	-	22 2510 0640	103,90	-	-	22 3510 0640	97,15	-	-	-	-	-	-	-	-
• 66,00	2.5984	-	-	22 2510 0660	103,90	-	-	22 3510 0660	97,15	-	-	-	-	-	-	-	-
• 68,00	2.6772	-	-	22 2510 0680	103,90	-	-	22 3510 0680	97,15	-	-	-	-	-	-	-	-
• 70,00	2.7559	-	-	22 2510 0700	103,90	-	-	22 3510 0700	97,15	-	-	-	-	-	-	-	-
• 72,00	2.8346	-	-	22 2510 0720	103,90	-	-	22 3510 0720	97,15	-	-	-	-	-	-	-	-
• 74,00	2.9134	-	-	22 2510 0740	103,90	-	-	22 3510 0740	97,15	-	-	-	-	-	-	-	-
• 76,00	2.9921	-	-	22 2510 0760	103,90	-	-	22 3510 0760	97,15	-	-	-	-	-	-	-	-
• 78,00	3.0709	-	-	22 2510 0780	114,75	-	-	22 3510 0780	108,00	-	-	-	-	-	-	-	-
• 80,00	3.1496	-	-	22 2510 0800	114,75	-	-	22 3510 0800	108,00	-	-	-	-	-	-	-	-
• 82,00	3.2283	-	-	22 2510 0820	114,75	-	-	22 3510 0820	108,00	-	-	-	-	-	-	-	-
• 84,00	3.3071	-	-	22 2510 0840	114,75	-	-	22 3510 0840	108,00	-	-	-	-	-	-	-	-
• 86,00	3.3858	-	-	22 2510 0860	114,75	-	-	22 3510 0860	108,00	-	-	-	-	-	-	-	-
• 88,00	3.4646	-	-	22 2510 0880	114,75	-	-	22 3510 0880	108,00	-	-	-	-	-	-	-	-
• 90,00	3.5433	-	-	22 2510 0900	134,70	-	-	22 3510 0900	127,85	-	-	-	-	-	-	-	-
• 92,00	3.6220	-	-	22 2510 0920	134,70	-	-	22 3510 0920	127,85	-	-	-	-	-	-	-	-
• 94,00	3.7008	-	-	22 2510 0940	134,70	-	-	22 3510 0940	127,85	-	-	-	-	-	-	-	-
• 96,00	3.7795	-	-	22 2510 0960	134,70	-	-	22 3510 0960	127,85	-	-	-	-	-	-	-	-
• 98,00	3.8583	-	-	22 2510 0980	134,70	-	-	22 3510 0980	127,85	-	-	-	-	-	-	-	-
• 100,00	3.9370	-	-	22 2510 1000	134,70	-	-	22 3510 1000	127,85	-	-	-	-	-	-	-	-
• 102,00	4.0157	-	-	22 2510 1020	153,50	-	-	22 3510 1020	146,65	-	-	-	-	-	-	-	-
• 104,00	4.0945	-	-	22 2510 1040	153,50	-	-	22 3510 1040	146,65	-	-	-	-	-	-	-	-
• 106,00	4.1732	-	-	22 2510 1060	153,50	-	-	22 3510 1060	146,65	-	-	-	-	-	-	-	-
• 108,00	4.2520	-	-	22 2510 1080	153,50	-	-	22 3510 1080	146,65	-	-	-	-	-	-	-	-
• 110,00	4.3307	-	-	22 2510 1100	153,50	-	-	22 3510 1100	146,65	-	-	-	-	-	-	-	-
• 112,00	4.4094	-	-	22 2510 1120	153,50	-	-	22 3510 1120	146,65	-	-	-	-	-	-	-	-
• 114,00	4.4882	-	-	22 2510 1140	153,50	-	-	22 3510 1140	146,65	-	-	-	-	-	-	-	-

MK 2+3 mit axialer Kühlung
MT 2+3 with axial cooling



MK 2,3,4,5 – Radiale Kühlung
mit Kühlmittelring
MT 2,3,4,5 – Radial coolant
with oil ring

Morsekegel
ISO 296 Typ BEK ·
Morse taper shank
ISO 296 type BEK

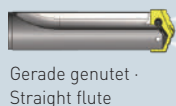
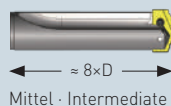
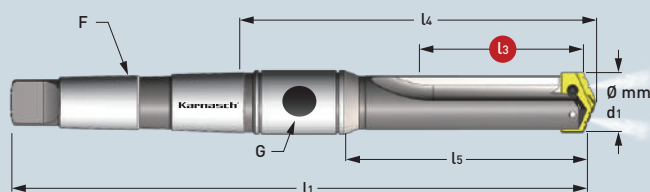

Art.	€	l3 Nutzlänge Max. drill depth	l5 Körperlänge Body-length	l4 Neue REF.- Länge REF.-length	l1 Gesamtlänge Overall length	F Morsekegel Morse taper	G Gewinde Pipe tap	Kühlmittelring Oil ring
mm Zoll / Inch	mm Zoll / Inch	mm Zoll / Inch	mm Zoll / Inch	mm Zoll / Inch	mm Zoll / Inch			Art. €
• 22 1040 04636 0640 Ø 64,0-88,0 mm 2.5197-3.4646" MÖGLICH · POSSIBLE Ø 64,0-76,0 mm 2.5197-2.9921" OPTIMAL · OPTIMAL	614,80							• 22 9002 05715 58,25
• 22 1040 04636 0780 Ø 78,0-88,0 mm 3.0709-3.4646" OPTIMAL · OPTIMAL	614,80	463,6 mm 18.2520"	508,0 mm 20.0000"	579,4 mm 22.8110"	722,3 mm 28.4370"	5	1/2"	
• 22 1040 05556 0900 Ø 90,0-114,0 mm 3.5433-4.4882" MÖGLICH · POSSIBLE Ø 90,0-100,0 mm 3.5433-3.9370" OPTIMAL · OPTIMAL	882,95							
• 22 1040 05556 1020 Ø 102,0-114,0 mm 4.0157-4.4882" OPTIMAL · OPTIMAL	882,95	555,6 mm 21.8740"	609,6 mm 24.0000"	681,1 mm 26.8150"	823,9 mm 32.4370"	5	1/2"	

Halter werden **ohne** Einsätze, inklusive 2x TORX Befestigungsschrauben und 1x TORX Schlüssel geliefert.
Holders are delivered **without** inserts including 2x TORX-screws and 1x TORX wrench.

Für Maschinen ohne axiale/radiale Kühlmittelzufuhr kann ein Kühlmittelring auf den Halter montiert werden. Details siehe Seite 356
For machines without radial/axial coolant supply a oil ring can be mounted on the holder. Details see page 356



Ersatz-Torxschrauben und Schlüssel mit Drehmomentangabe
Spare Torx-screws and wrench with torque specification

Ø Diameter		TORX	max. Drehmoment / Torque (N/cm)	Schlüssel / Wrench
mm	Zoll / Inch	€		€
9,5-11,0	0.3740-0.4331	22 9010 0095 3,50	84	22 9011 0084 9,90
11,5-12,5	0.4528-0.4921	22 9010 0115 3,50	84	22 9011 0175 9,90
13,0-17,5	0.5118-0.6890	22 9010 0130 3,50	175	22 9011 0305 10,90
18,0-24,0	0.7087-0.9449	22 9010 0180 3,50	305	22 9011 0690 11,70
25,0-35,0	0.9843-1.3780	22 9010 0250 3,60	690	22 9011 1370 12,70
36,0-65,0	1.4173-2.5591	22 9010 0360 3,65	1370	22 9011 1750 18,70
64,0-114,0	2.5197-4.4882	22 9010 0640 3,70	1750	

MK 2+3 mit axialer Kühlung
MT 2+3 with axial cooling



Bei Morsekonus 2+3 ist eine axiale Kühlung ohne Kühlmittelring möglich.
Hierzu muss das Gewinde des Kühlmittelringes (G) mit einer Schraube geschlossen werden.

With morse cone 2+3, axial cooling without coolant ring is possible.
For this, the thread of the coolant ring (G) must be closed with a screw.

Schraube für MK 2 / Screw for MT 2 = RC 1/16"



Schraube für MK 3 / Screw for MT 3 = RC 1/8"



Schnittdaten
Cutting data



Film
Movie



1302-1311

345





PULVERSTAHL · POWDER STEEL														HARTMETALL · CARBIDE													
Ø mm d1		Ø Zoll / Inch d1		22 2010		22 2510		22 3010		22 3510		22 4010		22 4510		22 5010		22 5510									
				Pulverstahl 25 STEEL-TEC beschichtet		Pulverstahl 15 STEEL-TEC beschichtet		Pulverstahl 25 ALU-TEC beschichtet		Pulverstahl 15 ALU-TEC beschichtet		Hartmetall 20/30 STEEL-TEC beschichtet		Hartmetall 20/30 STEEL-TEC beschichtet		Hartmetall 20/30 ALU-TEC beschichtet		Hartmetall 20/30 DIA-TEC beschichtet									
				Für Edelstahl, Stahl, Guss		Für legierte Stähle, Edelstahl, Stahl, Guss		Für Alu, Messing, Kupfer		Für Alu, Messing, Kupfer		Für Edelstahl, hochfester Stahl, gehärteter Stahl		Für alle Gussarten		Für Alu, Messing, Kupfer		Für abrasive Materialien wie: GFK, CFK, Graphit									
				Powder steel 25 STEEL-TEC coated		Powder steel 15 STEEL-TEC coated		Powder steel 25 ALU-TEC coated		Powder steel 15 ALU-TEC coated		Carbide 20/30 STEEL-TEC coated		Carbide 20/30 STEEL-TEC coated		Carbide 20/30 ALU-TEC coated		Carbide 20/30 DIA-TEC coated									
				For stainless steel, steel, cast iron		For alloy steel, stainless steel, steel, cast iron		For alu, brass, copper		For alloy steel, steel, cast iron		For stainless steel, high strength alloys, hardened steel		For all kinds of cast iron		For alu, brass, copper		For abrasive materials such as: fiberglass, carbon fiber, graphite									
		Art.		€		Art.		€		Art.		€		Art.		€		Art.		€							
• 36,00	1.4173	22 2010 0360	57,75	-	-	22 3010 0360	59,50	-	-	-	-	-	-	-	-	-	-	-	-	-	-						
• 37,00	1.4567	22 2010 0370	57,75	-	-	22 3010 0370	59,50	-	-	-	-	-	-	-	-	-	-	-	-	-	-						
• 38,00	1.4961	22 2010 0380	57,75	-	-	22 3010 0380	59,50	-	-	-	-	-	-	-	-	-	-	-	-	-	-						
• 39,00	1.5354	22 2010 0390	57,75	-	-	22 3010 0390	59,50	-	-	-	-	-	-	-	-	-	-	-	-	-	-						
• 40,00	1.5748	22 2010 0400	57,75	-	-	22 3010 0400	59,50	-	-	-	-	-	-	-	-	-	-	-	-	-	-						
• 41,00	1.6142	22 2010 0410	57,75	-	-	22 3010 0410	59,50	-	-	-	-	-	-	-	-	-	-	-	-	-	-						
• 42,00	1.6535	22 2010 0420	57,75	-	-	22 3010 0420	59,50	-	-	-	-	-	-	-	-	-	-	-	-	-	-						
• 43,00	1.6929	22 2010 0430	57,75	-	-	22 3010 0430	59,50	-	-	-	-	-	-	-	-	-	-	-	-	-	-						
• 44,00	1.7323	22 2010 0440	57,75	-	-	22 3010 0440	59,50	-	-	-	-	-	-	-	-	-	-	-	-	-	-						
• 45,00	1.7717	22 2010 0450	57,75	-	-	22 3010 0450	59,50	-	-	-	-	-	-	-	-	-	-	-	-	-	-						
• 46,00	1.8110	22 2010 0460	57,75	-	-	22 3010 0460	59,50	-	-	-	-	-	-	-	-	-	-	-	-	-	-						
• 47,00	1.8504	22 2010 0470	57,75	-	-	22 3010 0470	59,50	-	-	-	-	-	-	-	-	-	-	-	-	-	-						
• 48,00	1.8898	22 2010 0480	82,65	-	-	22 3010 0480	82,65	-	-	-	-	-	-	-	-	-	-	-	-	-	-						
• 49,00	1.9291	22 2010 0490	82,65	-	-	22 3010 0490	82,65	-	-	-	-	-	-	-	-	-	-	-	-	-	-						
• 50,00	1.9685	22 2010 0500	82,65	-	-	22 3010 0500	82,65	-	-	-	-	-	-	-	-	-	-	-	-	-	-						
• 51,00	2.0079	22 2010 0510	82,65	-	-	22 3010 0510	82,65	-	-	-	-	-	-	-	-	-	-	-	-	-	-						
• 52,00	2.0472	22 2010 0520	82,65	-	-	22 3010 0520	82,65	-	-	-	-	-	-	-	-	-	-	-	-	-	-						
• 53,00	2.0866	22 2010 0530	82,65	-	-	22 3010 0530	82,65	-	-	-	-	-	-	-	-	-	-	-	-	-	-						
• 54,00	2.1260	22 2010 0540	82,65	-	-	22 3010 0540	82,65	-	-	-	-	-	-	-	-	-	-	-	-	-	-						
• 55,00	2.1654	22 2010 0550	82,65	-	-	22 3010 0550	82,65	-	-	-	-	-	-	-	-	-	-	-	-	-	-						
• 56,00	2.2047	22 2010 0560	82,65	-	-	22 3010 0560	82,65	-	-	-	-	-	-	-	-	-	-	-	-	-	-						
• 57,00	2.2441	22 2010 0570	82,65	-	-	22 3010 0570	82,65	-	-	-	-	-	-	-	-	-	-	-	-	-	-						
• 58,00	2.2835	22 2010 0580	82,65	-	-	22 3010 0580	82,65	-	-	-	-	-	-	-	-	-	-	-	-	-	-						
• 59,00	2.3228	22 2010 0590	82,65	-	-	22 3010 0590	82,65	-	-	-	-	-	-	-	-	-	-	-	-	-	-						
• 60,00	2.3622	22 2010 0600	82,65	-	-	22 3010 0600	82,65	-	-	-	-	-	-	-	-	-	-	-	-	-	-						
• 61,00	2.4016	22 2010 0610	82,65	-	-	22 3010 0610	82,65	-	-	-	-	-	-	-	-	-	-	-	-	-	-						
• 62,00	2.4409	22 2010 0620	82,65	-	-	22 3010 0620	82,65	-	-	-	-	-	-	-	-	-	-	-	-	-	-						
• 63,00	2.4803	22 2010 0630	82,65	-	-	22 3010 0630	82,65	-	-	-	-	-	-	-	-	-	-	-	-	-	-						
• 64,00	2.5197	22 2010 0640	82,65	-	-	22 3010 0640	82,65	-	-	-	-	-	-	-	-	-	-	-	-	-	-						
• 65,00	2.5591	22 2010 0650	82,65	-	-	22 3010 0650	82,65	-	-	-	-	-	-	-	-	-	-	-	-	-	-						

Fortsetzung Seite 348 · Continued page 348

MK 2+3 mit axialer Kühlung
MT 2+3 with axial cooling



Morsekegel
ISO 296 Typ BEK ·
Morse taper shank
ISO 296 type BEK

MK 2,3,4,5 – Radiale Kühlung
mit Kühlmittelring
MT 2,3,4,5 – Radial coolant
with oil ring

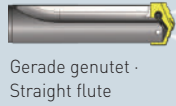
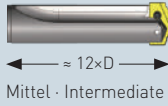
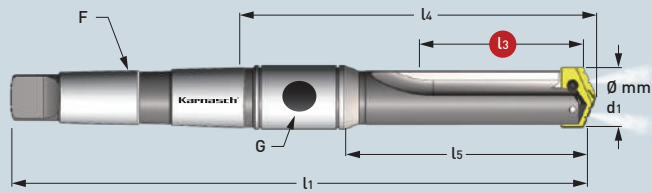

l3	l5	l4	l1	F	G	
Nutzlänge Max. drill depth	Körperlänge Body-length	Neue REF.- Länge REF.-length	Gesamtlänge Overall length	Morsekegel Morse taper	Gewinde Pipe tap	Kühlmittelring Oil ring

Art.	€	mm Zoll / Inch	mm Zoll / Inch	mm Zoll / Inch	mm Zoll / Inch			Art.	€
• 22 1040 05558 0360	613,75							• 22 9002 03175	32,20
Ø 36,0-47,0 mm 1.4173-1.8504" Ø 36,0-41,0 mm 1.4173-1.6142"									
		MÖGLICH · POSSIBLE OPTIMAL · OPTIMAL							
• 22 1040 05558 0420	613,75	558,8 mm 22.0000"	590,6 mm 23.2520"	644,6 mm 25.3780"	757,2 mm 29.8110"	4	1/4"		
Ø 42,0-47,0 mm 1.6535-1.8504"									
		OPTIMAL · OPTIMAL							
• 22 1040 06250 0480	756,15	625,0 mm 24.6063"	660,4 mm 26.0000"	714,4 mm 28.1260"	858,8 mm 33.8110"	5	1/4"	• 22 9002 04445	42,30
Ø 48,0-65,0 mm 1.8898-2.5591" Ø 48,0-55,0 mm 1.8898-2.1654"									
		MÖGLICH · POSSIBLE OPTIMAL · OPTIMAL							
• 22 1040 06250 0560	756,15	625,0 mm 24.6063"	660,4 mm 26.0000"	714,4 mm 28.1260"	858,8 mm 33.8110"	5	1/4"		
Ø 56,0-65,0 mm 2.2047-2.5591"									
		OPTIMAL · OPTIMAL							

Fortsetzung Seite 349 · Continued page 349

MK 2+3 mit axialer Kühlung
MT 2+3 with axial cooling



Bei Morsekonus 2+3 ist eine axiale Kühlung ohne Kühlmittelring möglich.
Hierzu muss das Gewinde des Kühlmittelringes (G) mit einer Schraube geschlossen werden.

With morse cone 2+3, axial cooling without coolant ring is possible.
For this, the thread of the coolant ring (G) must be closed with a screw.

Schraube für MK 2 / Screw for MT 2 = RC 1/16" **22 1030 0231 802** € 0,30

Schraube für MK 3 / Screw for MT 3 = RC 1/8" **22 1030 0231 803** € 0,30

Schnittdaten
Cutting data



Film
Movie



1302-1311

347





PULVERSTAHL · POWDER STEEL

HARTMETALL · CARBIDE

Ø mm d1	Ø Zoll / Inch d1	22 2010		22 2510		22 3010		22 3510		22 4010		22 4510		22 5010		22 5510	
		Art.	€	Art.	€	Art.	€	Art.	€	Art.	€	Art.	€	Art.	€	Art.	€
• 64,00	2.5197	-	-	22 2510 0640	103,90	-	-	22 3510 0640	97,15	-	-	-	-	-	-	-	-
• 66,00	2.5984	-	-	22 2510 0660	103,90	-	-	22 3510 0660	97,15	-	-	-	-	-	-	-	-
• 68,00	2.6772	-	-	22 2510 0680	103,90	-	-	22 3510 0680	97,15	-	-	-	-	-	-	-	-
• 70,00	2.7559	-	-	22 2510 0700	103,90	-	-	22 3510 0700	97,15	-	-	-	-	-	-	-	-
• 72,00	2.8346	-	-	22 2510 0720	103,90	-	-	22 3510 0720	97,15	-	-	-	-	-	-	-	-
• 74,00	2.9134	-	-	22 2510 0740	103,90	-	-	22 3510 0740	97,15	-	-	-	-	-	-	-	-
• 76,00	2.9921	-	-	22 2510 0760	103,90	-	-	22 3510 0760	97,15	-	-	-	-	-	-	-	-
• 78,00	3.0709	-	-	22 2510 0780	114,75	-	-	22 3510 0780	108,00	-	-	-	-	-	-	-	-
• 80,00	3.1496	-	-	22 2510 0800	114,75	-	-	22 3510 0800	108,00	-	-	-	-	-	-	-	-
• 82,00	3.2283	-	-	22 2510 0820	114,75	-	-	22 3510 0820	108,00	-	-	-	-	-	-	-	-
• 84,00	3.3071	-	-	22 2510 0840	114,75	-	-	22 3510 0840	108,00	-	-	-	-	-	-	-	-
• 86,00	3.3858	-	-	22 2510 0860	114,75	-	-	22 3510 0860	108,00	-	-	-	-	-	-	-	-
• 88,00	3.4646	-	-	22 2510 0880	114,75	-	-	22 3510 0880	108,00	-	-	-	-	-	-	-	-
• 90,00	3.5433	-	-	22 2510 0900	134,70	-	-	22 3510 0900	127,85	-	-	-	-	-	-	-	-
• 92,00	3.6220	-	-	22 2510 0920	134,70	-	-	22 3510 0920	127,85	-	-	-	-	-	-	-	-
• 94,00	3.7008	-	-	22 2510 0940	134,70	-	-	22 3510 0940	127,85	-	-	-	-	-	-	-	-
• 96,00	3.7795	-	-	22 2510 0960	134,70	-	-	22 3510 0960	127,85	-	-	-	-	-	-	-	-
• 98,00	3.8583	-	-	22 2510 0980	134,70	-	-	22 3510 0980	127,85	-	-	-	-	-	-	-	-
• 100,00	3.9370	-	-	22 2510 1000	134,70	-	-	22 3510 1000	127,85	-	-	-	-	-	-	-	-
• 102,00	4.0157	-	-	22 2510 1020	153,50	-	-	22 3510 1020	146,65	-	-	-	-	-	-	-	-
• 104,00	4.0945	-	-	22 2510 1040	153,50	-	-	22 3510 1040	146,65	-	-	-	-	-	-	-	-
• 106,00	4.1732	-	-	22 2510 1060	153,50	-	-	22 3510 1060	146,65	-	-	-	-	-	-	-	-
• 108,00	4.2520	-	-	22 2510 1080	153,50	-	-	22 3510 1080	146,65	-	-	-	-	-	-	-	-
• 110,00	4.3307	-	-	22 2510 1100	153,50	-	-	22 3510 1100	146,65	-	-	-	-	-	-	-	-
• 112,00	4.4094	-	-	22 2510 1120	153,50	-	-	22 3510 1120	146,65	-	-	-	-	-	-	-	-
• 114,00	4.4882	-	-	22 2510 1140	153,50	-	-	22 3510 1140	146,65	-	-	-	-	-	-	-	-

MK 2+3 mit axialer Kühlung
MT 2+3 with axial cooling



MK 2,3,4,5 – Radiale Kühlung
mit Kühlmittelring
MT 2,3,4,5 – Radial coolant
with oil ring

Morsekegel
ISO 296 Typ BEK ·
Morse taper shank
ISO 296 type BEK

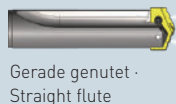
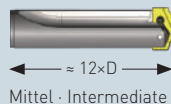
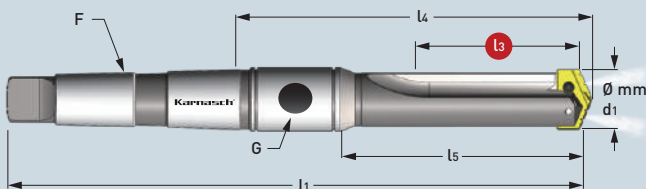

Art.	€	l3	l5	l4	l1	F	G	Art.	€
		Nutzlänge Max. drill depth	Körperlänge Body-length	Neue REF.- Länge REF.-length	Gesamtlänge Overall length	Morsekegel Morse taper	Gewinde Pipe tap	Kühlmittelring Oil ring	
		mm Zoll / Inch	mm Zoll / Inch	mm Zoll / Inch	mm Zoll / Inch				
• 22 1040 06600 0640	799,40							• 22 9002 05715	58,25
Ø 64,0-88,0 mm 2.5197-3.4646" MÖGLICH · POSSIBLE Ø 64,0-76,0 mm 2.5197-2.9921" OPTIMAL · OPTIMAL									
• 22 1040 06600 0780	799,40	660,0 mm 25.9843"	704,8 mm 27.7480"	776,2 mm 30.5591"	919,1 mm 36.1850"	5	1/2"		
Ø 78,0-88,0 mm 3.0709-3.4646" OPTIMAL · OPTIMAL									
• 22 1040 06850 0900	1.101,00								
Ø 90,0-114,0 mm 3.5433-4.4882" MÖGLICH · POSSIBLE Ø 90,0-100,0 mm 3.5433-3.9370" OPTIMAL · OPTIMAL									
• 22 1040 06850 1020	1.101,00	685,0 mm 26.9685"	739,7 mm 29.1220"	811,2 mm 31.9370"	954,0 mm 37.5591"	5	1/2"		
Ø 102,0-114,0 mm 4.0157-4.4882" OPTIMAL · OPTIMAL									

Halter werden **ohne** Einsätze, inklusive 2x TORX Befestigungsschrauben und 1x TORX Schlüssel geliefert.
Holders are delivered **without** inserts including 2x TORX-screws and 1x TORX wrench.

Für Maschinen ohne axiale/radiale Kühlmittelzufuhr kann ein Kühlmittelring auf den Halter montiert werden. Details siehe Seite 356
For machines without radial/axial coolant supply a oil ring can be mounted on the holder. Details see page 356



Ersatz-Torxschrauben und Schlüssel mit Drehmomentangabe
Spare Torx-screws and wrench with torque specification

Ø Diameter		TORX	max. Drehmoment / Torque (N/cm)	Schlüssel / Wrench
mm	Zoll / Inch	€		€
9,5-11,0	0.3740-0.4331	22 9010 0095	84	22 9011 0084
11,5-12,5	0.4528-0.4921	22 9010 0115	84	22 9011 0175
13,0-17,5	0.5118-0.6890	22 9010 0130	175	22 9011 0305
18,0-24,0	0.7087-0.9449	22 9010 0180	305	22 9011 0690
25,0-35,0	0.9843-1.3780	22 9010 0250	690	22 9011 1370
36,0-65,0	1.4173-2.5591	22 9010 0360	1370	22 9011 1750
64,0-114,0	2.5197-4.4882	22 9010 0640	1750	

MK 2+3 mit axialer Kühlung
MT 2+3 with axial cooling



Bei Morsekonus 2+3 ist eine axiale Kühlung ohne Kühlmittelring möglich.
Hierzu muss das Gewinde des Kühlmittelringes (G) mit einer Schraube geschlossen werden.

With morse cone 2+3, axial cooling without coolant ring is possible.
For this, the thread of the coolant ring (G) must be closed with a screw.

Schraube für MK 2 / Screw for MT 2 = RC 1/16"

22 1030 0231 802 € 0,30

Schraube für MK 3 / Screw for MT 3 = RC 1/8"

22 1030 0231 803 € 0,30

Schnittdaten
Cutting data



1302-1311

Film
Movie



349





PULVERSTAHL · POWDER STEEL										HARTMETALL · CARBIDE									
Ø mm d1		Ø Zoll / Inch d1		22 2010		22 2510		22 3010		22 3510		22 4010		22 4510		22 5010		22 5510	
				Pulverstahl 25 STEEL-TEC beschichtet		Pulverstahl 15 STEEL-TEC beschichtet		Pulverstahl 25 ALU-TEC beschichtet		Pulverstahl 15 ALU-TEC beschichtet		Hartmetall 20/30 STEEL-TEC beschichtet		Hartmetall 20/30 STEEL-TEC beschichtet		Hartmetall 20/30 ALU-TEC beschichtet		Hartmetall 20/30 DIA-TEC beschichtet	
				Für Edelstahl, Stahl, Guss		Für legierte Stähle, Edelstahl, Stahl, Guss		Für Alu, Messing, Kupfer		Für Alu, Messing, Kupfer		Für Edelstahl, hochfester Stahl, gehärteter Stahl		Für alle Gussarten		Für Alu, Messing, Kupfer		Für abrasive Materialien wie: GFK, CFK, Graphit	
				Powder steel 25 STEEL-TEC coated		Powder steel 15 STEEL-TEC coated		Powder steel 25 ALU-TEC coated		Powder steel 15 ALU-TEC coated		Carbide 20/30 STEEL-TEC coated		Carbide 20/30 STEEL-TEC coated		Carbide 20/30 ALU-TEC coated		Carbide 20/30 DIA-TEC coated	
				For stainless steel, steel, cast iron		For alloy steel, stainless steel, steel, cast iron		For alu, brass, copper		For alloy steel, steel, cast iron		For stainless steel, high strength alloys, hardened steel		For all kinds of cast iron		For alu, brass, copper		For abrasive materials such as: fiberglass, carbon fiber, graphite	
Art.	€	Art.	€	Art.	€	Art.	€	Art.	€	Art.	€	Art.	€	Art.	€	Art.	€	Art.	€
• 36,00	1.4173	22 2010 0360	57,75	-	-	22 3010 0360	59,50	-	-	-	-	-	-	-	-	-	-	-	-
• 37,00	1.4567	22 2010 0370	57,75	-	-	22 3010 0370	59,50	-	-	-	-	-	-	-	-	-	-	-	-
• 38,00	1.4961	22 2010 0380	57,75	-	-	22 3010 0380	59,50	-	-	-	-	-	-	-	-	-	-	-	-
• 39,00	1.5354	22 2010 0390	57,75	-	-	22 3010 0390	59,50	-	-	-	-	-	-	-	-	-	-	-	-
• 40,00	1.5748	22 2010 0400	57,75	-	-	22 3010 0400	59,50	-	-	-	-	-	-	-	-	-	-	-	-
• 41,00	1.6142	22 2010 0410	57,75	-	-	22 3010 0410	59,50	-	-	-	-	-	-	-	-	-	-	-	-
• 42,00	1.6535	22 2010 0420	57,75	-	-	22 3010 0420	59,50	-	-	-	-	-	-	-	-	-	-	-	-
• 43,00	1.6929	22 2010 0430	57,75	-	-	22 3010 0430	59,50	-	-	-	-	-	-	-	-	-	-	-	-
• 44,00	1.7323	22 2010 0440	57,75	-	-	22 3010 0440	59,50	-	-	-	-	-	-	-	-	-	-	-	-
• 45,00	1.7717	22 2010 0450	57,75	-	-	22 3010 0450	59,50	-	-	-	-	-	-	-	-	-	-	-	-
• 46,00	1.8110	22 2010 0460	57,75	-	-	22 3010 0460	59,50	-	-	-	-	-	-	-	-	-	-	-	-
• 47,00	1.8504	22 2010 0470	57,75	-	-	22 3010 0470	59,50	-	-	-	-	-	-	-	-	-	-	-	-
• 48,00	1.8898	22 2010 0480	82,65	-	-	22 3010 0480	82,65	-	-	-	-	-	-	-	-	-	-	-	-
• 49,00	1.9291	22 2010 0490	82,65	-	-	22 3010 0490	82,65	-	-	-	-	-	-	-	-	-	-	-	-
• 50,00	1.9685	22 2010 0500	82,65	-	-	22 3010 0500	82,65	-	-	-	-	-	-	-	-	-	-	-	-
• 51,00	2.0079	22 2010 0510	82,65	-	-	22 3010 0510	82,65	-	-	-	-	-	-	-	-	-	-	-	-
• 52,00	2.0472	22 2010 0520	82,65	-	-	22 3010 0520	82,65	-	-	-	-	-	-	-	-	-	-	-	-
• 53,00	2.0866	22 2010 0530	82,65	-	-	22 3010 0530	82,65	-	-	-	-	-	-	-	-	-	-	-	-
• 54,00	2.1260	22 2010 0540	82,65	-	-	22 3010 0540	82,65	-	-	-	-	-	-	-	-	-	-	-	-
• 55,00	2.1654	22 2010 0550	82,65	-	-	22 3010 0550	82,65	-	-	-	-	-	-	-	-	-	-	-	-
• 56,00	2.2047	22 2010 0560	82,65	-	-	22 3010 0560	82,65	-	-	-	-	-	-	-	-	-	-	-	-
• 57,00	2.2441	22 2010 0570	82,65	-	-	22 3010 0570	82,65	-	-	-	-	-	-	-	-	-	-	-	-
• 58,00	2.2835	22 2010 0580	82,65	-	-	22 3010 0580	82,65	-	-	-	-	-	-	-	-	-	-	-	-
• 59,00	2.3228	22 2010 0590	82,65	-	-	22 3010 0590	82,65	-	-	-	-	-	-	-	-	-	-	-	-
• 60,00	2.3622	22 2010 0600	82,65	-	-	22 3010 0600	82,65	-	-	-	-	-	-	-	-	-	-	-	-
• 61,00	2.4016	22 2010 0610	82,65	-	-	22 3010 0610	82,65	-	-	-	-	-	-	-	-	-	-	-	-
• 62,00	2.4409	22 2010 0620	82,65	-	-	22 3010 0620	82,65	-	-	-	-	-	-	-	-	-	-	-	-
• 63,00	2.4803	22 2010 0630	82,65	-	-	22 3010 0630	82,65	-	-	-	-	-	-	-	-	-	-	-	-
• 64,00	2.5197	22 2010 0640	82,65	-	-	22 3010 0640	82,65	-	-	-	-	-	-	-	-	-	-	-	-
• 65,00	2.5591	22 2010 0650	82,65	-	-	22 3010 0650	82,65	-	-	-	-	-	-	-	-	-	-	-	-

Fortsetzung Seite 352 · Continued page 352

MK 2+3 mit axialer Kühlung
MT 2+3 with axial cooling

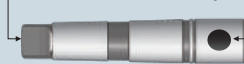

Morsekegel
ISO 296 Typ BEK ·
Morse taper shank
ISO 296 type BEK

MK 2,3,4,5 – Radiale Kühlung
mit Kühlmittelring
MT 2,3,4,5 – Radial coolant
with oil ring

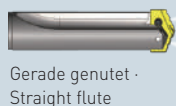
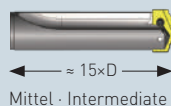
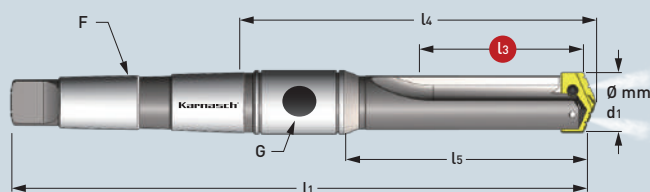

l3	l5	l4	l1	F	G	
Nutzlänge	Körperlänge	Neue REF.- Länge	Gesamtlänge	Morsekegel	Gewinde	Kühlmittelring
Max. drill depth	Body-length	REF.-length	Overall length	Morse taper	Pipe tap	Oil ring

Art.	€	mm Zoll / Inch	mm Zoll / Inch	mm Zoll / Inch	mm Zoll / Inch			Art.	€
• 22 1040 07874 0360	797,85							• 22 9002 03175	32,20
Ø 36,0-47,0 mm 1.4173-1.8504"									
Ø 36,0-41,0 mm 1.4173-1.6142"									
• 22 1040 07874 0420	797,85	787,4 mm 31.0000"	819,2 mm 32.2520"	873,2 mm 34.3780"	985,8 mm 38.8110"	4	1/4"		
Ø 42,0-47,0 mm 1.6535-1.8504"									
• 22 1040 08790 0480	945,35	879,0 mm 34.6063"	914,4 mm 36.0000"	968,4 mm 38.1260"	1112,8 mm 43.8110"	5	1/4"	• 22 9002 04445	42,30
Ø 48,0-65,0 mm 1.8898-2.5591"									
Ø 48,0-55,0 mm 1.8898-2.1654"									
• 22 1040 08790 0560	945,35	879,0 mm 34.6063"	914,4 mm 36.0000"	968,4 mm 38.1260"	1112,8 mm 43.8110"	5	1/4"		
Ø 56,0-65,0 mm 2.2047-2.5591"									

Fortsetzung Seite 353 · Continued page 353

MK 2+3 mit axialer Kühlung
MT 2+3 with axial cooling



Bei Morsekonus 2+3 ist eine axiale Kühlung ohne Kühlmittelring möglich.
Hierzu muss das Gewinde des Kühlmittelringes (G) mit einer Schraube geschlossen werden.

With morse cone 2+3, axial cooling without coolant ring is possible.
For this, the thread of the coolant ring (G) must be closed with a screw.

Schraube für MK 2 / Screw for MT 2 = RC 1/16" **22 1030 0231 802** € 0,30

Schraube für MK 3 / Screw for MT 3 = RC 1/8" **22 1030 0231 803** € 0,30

Schnittdaten
Cutting data



Film
Movie



1302-1311



351





PULVERSTAHL · POWDER STEEL

HARTMETALL · CARBIDE

Ø mm d1	Ø Zoll / Inch d1	22 2010		22 2510		22 3010		22 3510		22 4010		22 4510		22 5010		22 5510	
		Art.	€	Art.	€	Art.	€	Art.	€	Art.	€	Art.	€	Art.	€	Art.	€
• 64,00	2.5197	-	-	22 2510 0640	103,90	-	-	22 3510 0640	97,15	-	-	-	-	-	-	-	-
• 66,00	2.5984	-	-	22 2510 0660	103,90	-	-	22 3510 0660	97,15	-	-	-	-	-	-	-	-
• 68,00	2.6772	-	-	22 2510 0680	103,90	-	-	22 3510 0680	97,15	-	-	-	-	-	-	-	-
• 70,00	2.7559	-	-	22 2510 0700	103,90	-	-	22 3510 0700	97,15	-	-	-	-	-	-	-	-
• 72,00	2.8346	-	-	22 2510 0720	103,90	-	-	22 3510 0720	97,15	-	-	-	-	-	-	-	-
• 74,00	2.9134	-	-	22 2510 0740	103,90	-	-	22 3510 0740	97,15	-	-	-	-	-	-	-	-
• 76,00	2.9921	-	-	22 2510 0760	103,90	-	-	22 3510 0760	97,15	-	-	-	-	-	-	-	-
• 78,00	3.0709	-	-	22 2510 0780	114,75	-	-	22 3510 0780	108,00	-	-	-	-	-	-	-	-
• 80,00	3.1496	-	-	22 2510 0800	114,75	-	-	22 3510 0800	108,00	-	-	-	-	-	-	-	-
• 82,00	3.2283	-	-	22 2510 0820	114,75	-	-	22 3510 0820	108,00	-	-	-	-	-	-	-	-
• 84,00	3.3071	-	-	22 2510 0840	114,75	-	-	22 3510 0840	108,00	-	-	-	-	-	-	-	-
• 86,00	3.3858	-	-	22 2510 0860	114,75	-	-	22 3510 0860	108,00	-	-	-	-	-	-	-	-
• 88,00	3.4646	-	-	22 2510 0880	114,75	-	-	22 3510 0880	108,00	-	-	-	-	-	-	-	-
• 90,00	3.5433	-	-	22 2510 0900	134,70	-	-	22 3510 0900	127,85	-	-	-	-	-	-	-	-
• 92,00	3.6220	-	-	22 2510 0920	134,70	-	-	22 3510 0920	127,85	-	-	-	-	-	-	-	-
• 94,00	3.7008	-	-	22 2510 0940	134,70	-	-	22 3510 0940	127,85	-	-	-	-	-	-	-	-
• 96,00	3.7795	-	-	22 2510 0960	134,70	-	-	22 3510 0960	127,85	-	-	-	-	-	-	-	-
• 98,00	3.8583	-	-	22 2510 0980	134,70	-	-	22 3510 0980	127,85	-	-	-	-	-	-	-	-
• 100,00	3.9370	-	-	22 2510 1000	134,70	-	-	22 3510 1000	127,85	-	-	-	-	-	-	-	-
• 102,00	4.0157	-	-	22 2510 1020	153,50	-	-	22 3510 1020	146,65	-	-	-	-	-	-	-	-
• 104,00	4.0945	-	-	22 2510 1040	153,50	-	-	22 3510 1040	146,65	-	-	-	-	-	-	-	-
• 106,00	4.1732	-	-	22 2510 1060	153,50	-	-	22 3510 1060	146,65	-	-	-	-	-	-	-	-
• 108,00	4.2520	-	-	22 2510 1080	153,50	-	-	22 3510 1080	146,65	-	-	-	-	-	-	-	-
• 110,00	4.3307	-	-	22 2510 1100	153,50	-	-	22 3510 1100	146,65	-	-	-	-	-	-	-	-
• 112,00	4.4094	-	-	22 2510 1120	153,50	-	-	22 3510 1120	146,65	-	-	-	-	-	-	-	-
• 114,00	4.4882	-	-	22 2510 1140	153,50	-	-	22 3510 1140	146,65	-	-	-	-	-	-	-	-

MK 2+3 mit axialer Kühlung
MT 2+3 with axial cooling



MK 2,3,4,5 – Radiale Kühlung
mit Kühlmittelring
MT 2,3,4,5 – Radial coolant
with oil ring

Morsekegel
ISO 296 Typ BEK
Morse taper shank
ISO 296 type BEK

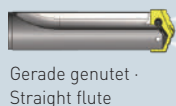
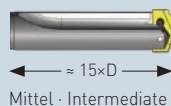
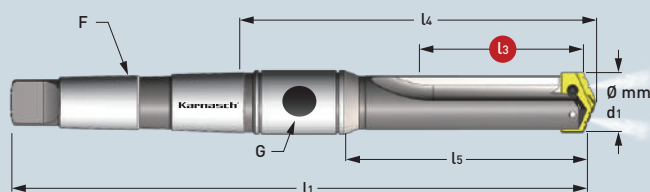

Art.	€	l3 Nutzlänge Max. drill depth	l5 Körperlänge Body-length	l4 Neue REF.- Länge REF.-length	l1 Gesamtlänge Overall length	F Morsekegel Morse taper	G Gewinde Pipe tap	Kühlmittelring Oil ring
mm Zoll / Inch	mm Zoll / Inch	mm Zoll / Inch	mm Zoll / Inch	mm Zoll / Inch			Art.	€
• 22 1040 08890 0640 Ø 64,0-88,0 mm 2.5197-3.4646" MÖGLICH · POSSIBLE Ø 64,0-76,0 mm 2.5197-2.9921" OPTIMAL · OPTIMAL	999,25							• 22 9002 05715 58,25
• 22 1040 08890 0780 Ø 78,0-88,0 mm 3.0709-3.4646" OPTIMAL · OPTIMAL	999,25	889,0 mm 35.0000"	933,4 mm 36.7480"	1004,8 mm 39.5591"	1147,7 mm 45.1850"	5	1/2"	
• 22 1040 09390 0900 Ø 90,0-114,0 mm 3.5433-4.4882" MÖGLICH · POSSIBLE Ø 90,0-100,0 mm 3.5433-3.9370" OPTIMAL · OPTIMAL	1.376,25							
• 22 1040 09390 1020 Ø 102,0-114,0 mm 4.0157-4.4882" OPTIMAL · OPTIMAL	1.376,35	939,0 mm 36.9685"	993,7 mm 39.1220"	1065,2 mm 41.9370"	1208,0 mm 47.5591"	5	1/2"	

Halter werden **ohne** Einsätze, inklusive 2x TORX Befestigungsschrauben und 1x TORX Schlüssel geliefert.
Holders are delivered **without** inserts including 2x TORX-screws and 1x TORX wrench.

Für Maschinen ohne axiale/radiale Kühlmittelzufuhr kann ein Kühlmittelring auf den Halter montiert werden. Details siehe Seite 356
For machines without radial/axial coolant supply a oil ring can be mounted on the holder. Details see page 356



Ersatz-Torxschrauben und Schlüssel mit Drehmomentangabe
Spare Torx-screws and wrench with torque specification

Ø Diameter		TORX	max. Drehmoment / Torque (N/cm)	Schlüssel / Wrench
mm	Zoll / Inch	€		€
9,5-11,0	0.3740-0.4331	22 9010 0095 3,50	84	22 9011 0084 9,90
11,5-12,5	0.4528-0.4921	22 9010 0115 3,50	84	22 9011 0175 9,90
13,0-17,5	0.5118-0.6890	22 9010 0130 3,50	175	22 9011 0305 10,90
18,0-24,0	0.7087-0.9449	22 9010 0180 3,50	305	22 9011 0690 11,70
25,0-35,0	0.9843-1.3780	22 9010 0250 3,60	690	22 9011 1370 12,70
36,0-65,0	1.4173-2.5591	22 9010 0360 3,65	1370	22 9011 1750 18,70
64,0-114,0	2.5197-4.4882	22 9010 0640 3,70	1750	

MK 2+3 mit axialer Kühlung
MT 2+3 with axial cooling



Bei Morsekonus 2+3 ist eine axiale Kühlung ohne Kühlmittelring möglich.
Hierzu muss das Gewinde des Kühlmittelringes (G) mit einer Schraube geschlossen werden.

With morse cone 2+3, axial cooling without coolant ring is possible.
For this, the thread of the coolant ring (G) must be closed with a screw.

Schraube für MK 2 / Screw for MT 2 = RC 1/16"

22 1030 0231 802 € 0,30

Schraube für MK 3 / Screw for MT 3 = RC 1/8"

22 1030 0231 803 € 0,30

Schnittdaten
Cutting data



Film
Movie



1302-1311

353



MORSEKONUS · MORSE TAPER
ISO 296 TYP BEK / TYPE BEK **3**

21 0036

€ 51,85

20 1465

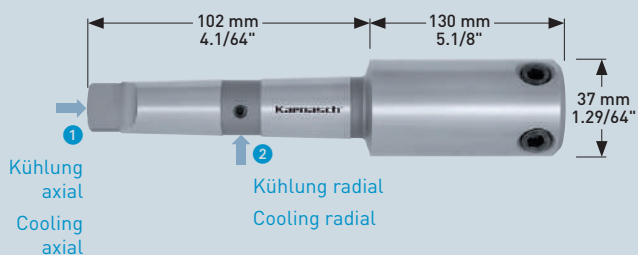

EIGENSCHAFTEN · PROPERTIES

Morsekonus 3 Aufnahme mit obiger **1** und/oder seitlicher **2** Kühlmittelzufuhr.

Vorteile:

- Ein Morsekonus für alle Bohrer.
- Robust
- Preiswert

Morse taper 3 tool holder with top **1** and / or lateral **2** cooling supply.

Advantages:

- One morse taper for all drills.
- Robust
- Good value

20 1465

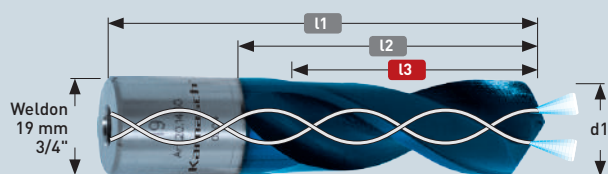

d1 Ø mm	d1 Ø Zoll/ Inch	Art.	Nutzlänge Max. drill depth L3		Spirallänge Spiral length L2		Gesamtlänge Overall length L1		€
			mm	Zoll/Inch	mm	Zoll/Inch	mm	Zoll/Inch	
● 14	35/64	20 1465 014	50	1.31/32	67	2.41/64	90	3.35/64	80,85
● 15	19/32	20 1465 015	50	1.31/32	67	2.41/64	90	3.35/64	80,85
● 16	5/8	20 1465 016	50	1.31/32	67	2.41/64	90	3.35/64	83,85
● 17	43/64	20 1465 017	55	2.11/64	67	2.41/64	90	3.35/64	83,85
● 18	45/64	20 1465 018	55	2.11/64	67	2.41/64	90	3.35/64	83,85
● 19	3/4	20 1465 019	55	2.11/64	67	2.41/64	90	3.35/64	83,85
● 20	25/32	20 1465 020	55	2.11/64	67	2.41/64	90	3.35/64	90,25
● 21	53/64	20 1465 021	55	2.11/64	67	2.41/64	90	3.35/64	90,25
● 22	55/64	20 1465 022	55	2.11/64	67	2.41/64	90	3.35/64	97,35
● 23	29/32	20 1465 023	55	2.11/64	67	2.41/64	90	3.35/64	98,15
● 24	15/16	20 1465 024	55	2.11/64	67	2.41/64	90	3.35/64	109,30
● 25	63/64	20 1465 025	55	2.11/64	67	2.41/64	90	3.35/64	109,30
● 26	1.1/32	20 1465 026	55	2.11/64	67	2.41/64	90	3.35/64	123,80
● 27	1.1/16	20 1465 027	55	2.11/64	67	2.41/64	90	3.35/64	123,80
● 28	1.7/64	20 1465 028	55	2.11/64	67	2.41/64	90	3.35/64	143,50
● 30	1.3/16	20 1465 030	55	2.11/64	67	2.41/64	90	3.35/64	159,35
● 32	1.17/64	20 1465 032	55	2.11/64	67	2.41/64	90	3.35/64	172,05

EIGENSCHAFTEN · PROPERTIES

ASP-Pulverstahl Bohrer mit Innenkühlung +
BLUE-TEC Beschichtung

Gefertigt aus pulvermetallurgischen Schnellarbeitsstahl für:

- Hohe Warmhärte
- Hohe Druckbelastbarkeit
- Hohe Verschleißfestigkeit

Mit BLUE-TEC Beschichtung für eine nochmalige wesentliche Erhöhung der Standzeit auch bei Trockenbearbeitung (ohne/wenig Kühlung)

Zum Bohren in:

- Alle Sorten von Baustähle, Guss und Leichtmetallen.
- Edeltähle (V2A / V4A)
- Rost- und Säurebeständige Stähle
- Titan- und Titanlegierungen

Diese Bohrer sind bis zu 10-mal nachschleifbar und haben somit ein hervorragendes Preis-Leistungs-Verhältnis.

ASP-Powder steel twist drills with internal cooling
supply + BLUE-TEC coating

Made of powder metallurgy high speed steel which results to:

- good thermal curing
- high pressure resistance
- high wear resistance

With BLUE-TEC coating for a further substantial increase in service life also when machining dry (no/little cooling)

For drilling in:

- All kinds of structural steel, cast iron, non ferrous metals.
- High-alloyed chromium steel such as stainless (V2A / V4A)
- Acid resistant steel
- Titanium and titanium alloys

The drills can be resharpended up to 10 times and thus have an excellent cost - performance ratio.

Schnittdaten
Cutting data

Film
Movie



1296



MORSEKONUS - MORSE TAPER
ISO 296 TYP BEK / TYPE BEK

3

20 1400

€ 56,15



Wir empfehlen unsere Hartmetall-bestückten Kernbohrer HARD-LINE Ø 12-60 mm | 15/32-2.23/64" siehe Seite 366/368

We recommend our carbide-tipped annular cutters HARD-LINE Ø 12-60 mm | 15/32-2.23/64" see page 366/368

MORSEKONUS - MORSE TAPER
ISO 296 TYP BEK / TYPE BEK

3

20 1401

€ 59,15

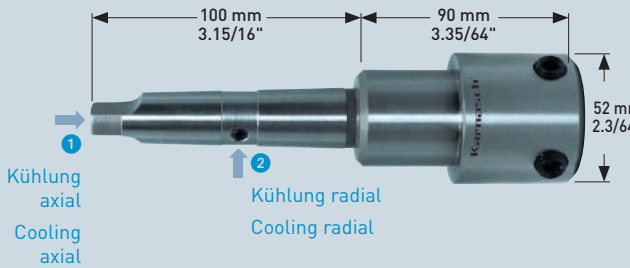

Wir empfehlen unsere Hartmetall-bestückten Kernbohrer HARD-LINE Ø 61-150 mm | 2.13/32-5.29/32" siehe Seite 366/368

We recommend our carbide-tipped annular cutters HARD-LINE Ø 61-150 mm | 2.13/32-5.29/32" see page 366/368

Die Kombination Kernbohrer mit Säge-Bohranlagen ist nicht für die Serienproduktion gedacht, ist aber eine hervorragende Möglichkeit sehr preiswert große Bohrungen zu fertigen.

The combination saw-drilling machines with annular cutters is not intended for mass production, it represents an excellent way to produce very inexpensive large holes.



Schnittdaten
Cutting data



1295

Film
Movie



355

MONTAGE + ZUBEHÖR DES KÜHLMITTELRINGS • OIL RING ASSEMBLY AND ACCESSORIES

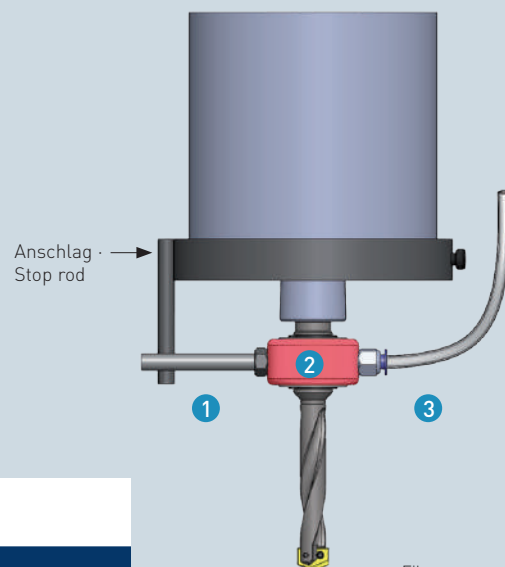
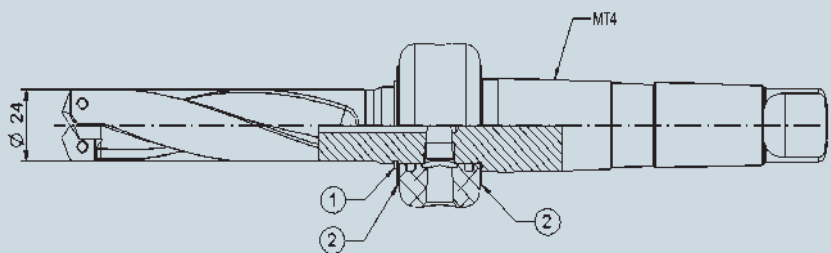
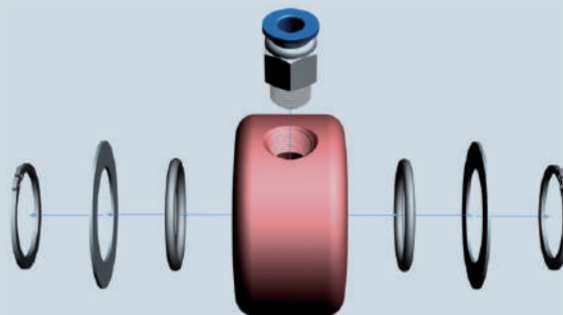
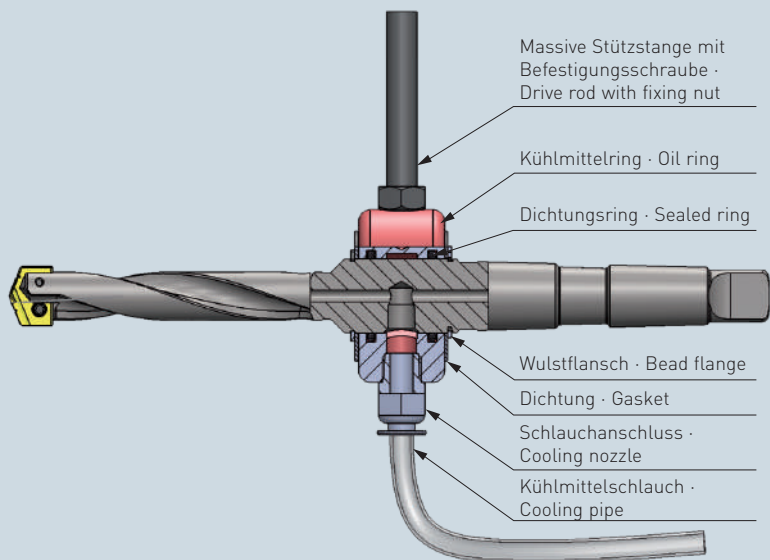

ACHTUNG: Bei 4 Stück Werkzeughalter gibt es einen Unterschied im Zusammenbau des Kühlmittelrings.
 ATTENTION: There here is a difference in the assembly of the coolant ring with 4 holders.

Anleitung Zusammenbau / Installation instructions

Halter mit Artikelnummer / Corresponding holder article number	1 Anzahl der Sicherungsringe 1 Stück / Number of retaining ring to be installed 1 piece	2 Anzahl der Unterlegscheiben 2 Stück / Number of washer to be installed 2 pieces
22 1030 01365 0250	1	2
22 1030 01873 0250	1	2
22 1030 02890 0250	1	2
22 1040 00857 0250	1	2

Film
Movie



1
Stützstange mit
Befestigungsschraube ·
Drive rod with fixing nut

2
Kühlmittelring · Oil ring

3
Kühlmittelschlauch ·
Cooling pipe

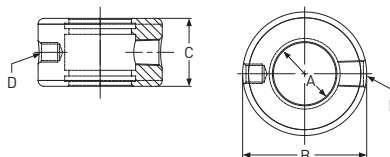
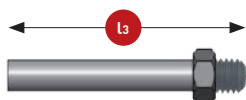

Art.	€	l3 mm	Art.	€	Ø-Halter Ø-Holder	A Innen-Ø mm Inside-Ø mm	B Außen-Ø mm Outside-Ø mm	C Dicke mm Thickness mm	D Stützstangen Gewinde · Driving rod thread	E Schlauchanschluss Gewinde · Cooling nozzle thread	Art.	€
• 22 9001 08250	5,05	250	22 9002 01905	22,10	9,5-17,5	19,05	44,45	22,23	M8 × 1,25	1/8"	• 22 9003 18	1,80
			22 9002 02540	24,85	18-29	25,40	53,97	28,57	M8 × 1,25	1/8"		
• 22 9001 10250	5,35	250	22 9002 03175	32,20	30-47	31,75	63,50	34,92	M10 × 1,5	1/4"	• 22 9003 14	2,65
			22 9002 04445	42,30	48-65	44,45	76,20	34,92	M10 × 1,5	1/4"		
• 22 9001 12250	5,55	250	22 9002 05715	58,25	64-114	57,15	95,27	44,45	M12 × 1,75	1/2"	• 22 9003 12	4,60

Ihr Spezialist für Zerspanungswerkzeuge:

Karnasch
PROFESSIONAL TOOLS
GERMANY



ÖSTERREICH:

Grampelhuber GmbH

Koaserbauerstrasse 18

4810 Gmunden / Austria

Telefon: +43 (0)7612 - 64902-0

Telefax: +43 (0)7612 - 64902-8

office@grampelhuber.at

www.grampelhuber.at

HAUPTKATALOG · MAIN CATALOGUE



KARNASCH WORLDWIDE

EUROPE AUSTRIA · BELGIUM · BOSNIA HERZEGOVINA · BRITISH VIRGIN ISLANDS · BULGARIA · CROATIA · CYPRUS · CZECH REPUBLIC · DENMARK · ESTONIA · FAROE ISLANDS · FINLAND · FRANCE · GEORGIA · GERMANY · GREECE · HUNGARY · ICELAND · IRELAND · ITALY · KOSOVO · LATVIA · LITHUANIA · LUXEMBOURG · MALTA · MOLDOVA · MONACO · MONTENEGRO · NETHERLANDS · NORWAY · POLAND · PORTUGAL · REPUBLIC OF MOLDOVA · REPUBLIC OF MACEDONIA · ROMANIA · RUSSIA · SAN MARINO · SLOVAKIA · SLOVENIA · SPAIN · SWEDEN · SWITZERLAND · TURKEY · UKRAINE · UNITED KINGDOM · WHITE RUSSIA/BELARUS · **AFRICA** ANGOLA · EGYPT · EQUATORIAL GUINEA · LYBIA · MOROCCO · NIGERIA · REPUBLIC OF MAURITIUS · SAUDI ARABIA · SOUTH AFRICA · UAE/UNITED ARAB EMIRATES · **ASIA** ARMENIA · AZERBAIJAN · CHINA · DEMOCRATIC PEOPLE'S REPUBLIC OF KOREA · GEORGIA · HONG KONG · INDIA · INDONESIA · IRAN · ISRAEL · JAPAN · JORDAN · KAZAKHSTAN · KUWAIT · LEBANON · MALAYSIA · PHILIPPINES · QATAR · UAE/UNITED ARAB EMIRATES · SINGAPORE · SYRIA · TAIWAN · THAILAND · TUNESIEN REPUBLIC · VIETNAM · YEMEN · **SOUTH AMERICA** ARGENTINIA · BRAZIL · CHILE · COLOMBIA · EQUADOR · PERU · REPUBLIC OF VENEZUELA · **AMERICA** AMERICAN SAMOA · CANADA · USA · **MIDDLE AMERICA** COSTA RICA · EL SALVADOR · MEXICO · AUSTRALIA · **OCEANIA** CALEDONIA · NEW ZEALAND