

# 2 BOHREN DRILLING

VOLLHARTMETALL HOCHLEISTUNGSBOHRER  
SOLID CARBIDE HIGH PERFORMANCE TWIST DRILL



2.1

☞ 227-296

VOLLHARTMETALL REIBAHLEN  
SOLID CARBIDE REAMERS



2.2

☞ 297-302

SPATENBOHRER  
SPADE DRILLS

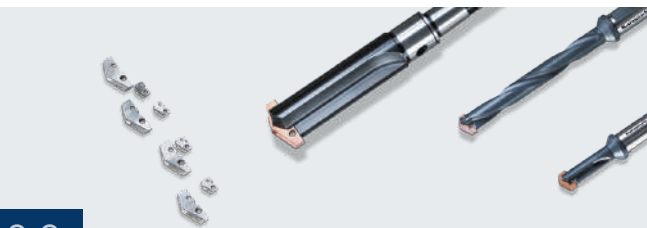

2.3

☞ 303-356

KERNBOHRER  
ANNULAR CUTTERS

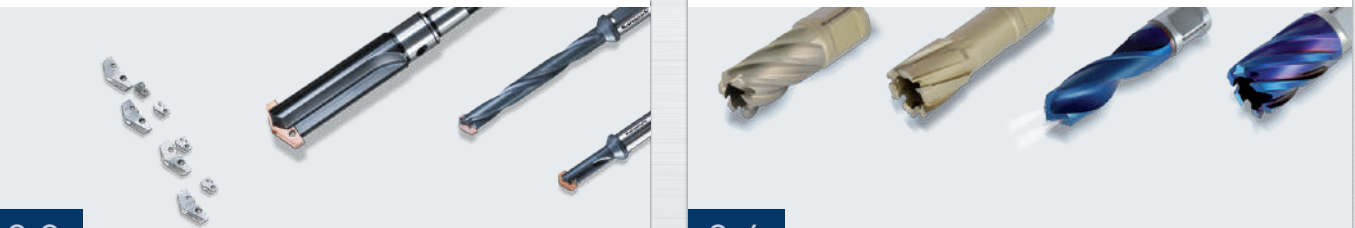

2.4

☞ 357-562

LOCHSÄGEN  
HOLE SAWS



2.5

☞ 563-604

STUFENBOHRER · BLECHSCHÄLBOHRER  
STEP DRILLS · TUBE AND SHEET DRILLS



2.6

☞ 605-620

HSS SPIRALBOHRER · GEWINDEBOHRER  
HSS TWIST DRILLS · TAPS



2.7

☞ 621-626

VHM-GEWINDEBOHRER-AUSBOHRER  
SOLID CARBIDE DRILLS TO REMOVE JAMMED TAPS

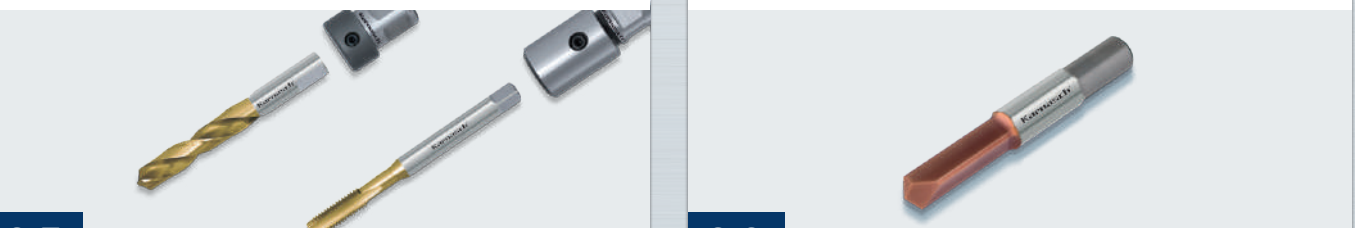

2.8

☞ 627-630

1



2



3



4



5



6



7



8



9



Index

## VOLLHARTMETALL HOCHLEISTUNGSBOHRER · MICROBOHRER

## SOLID CARBIDE HIGH PERFORMANCE TWIST DRILL · MICRO TWIST DRILL

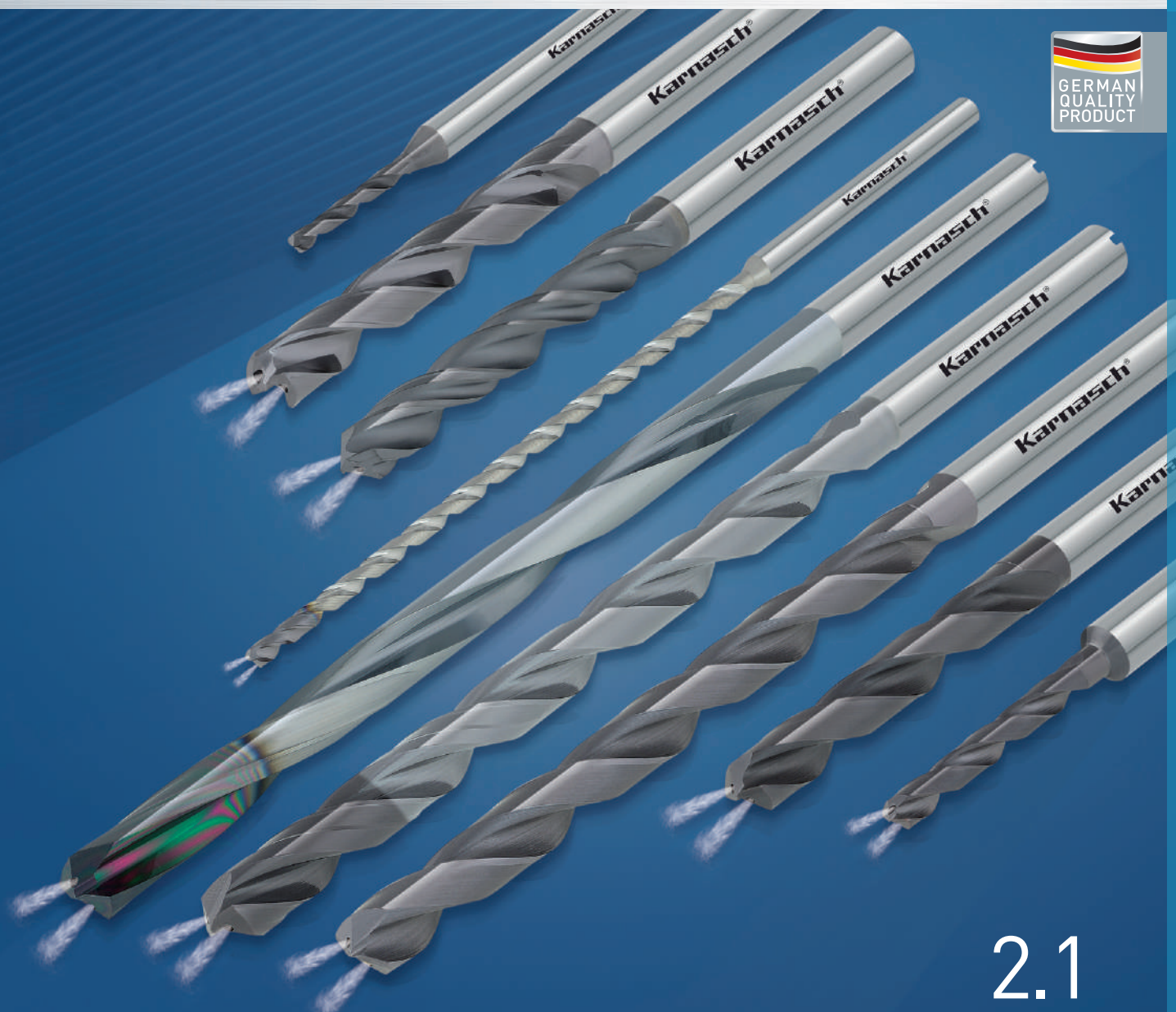

2.1



## INHALTSVERZEICHNIS · TABLE OF CONTENTS

Art.	Vollhartmetallbohrer / Solid carbide drills	Material		HSC high-speed cutting	HRC < 50	HRC < 52	HRC 50-70
22 0321	Ø 0,8 - 2,95 	MICRO GRAIN	232	✓		✓	
22 0322	Ø 0,8 - 2,95 < 30xD 	MICRO GRAIN	234	✓			
22 0341	Ø 0,1 - 3,0 < 6xD 	MICRO GRAIN	236	✓		✓	
22 0360	Ø 0,5 - 3,0 < 10xD 	MICRO GRAIN	239	✓			
22 0390	Ø 3,0 - 12,0 < 50xD 	MICRO GRAIN	244-245	✓			
22 0392	Ø 2,0 - 12,0 < 40xD 	MICRO GRAIN	246-249	✓			
22 0802	Ø 3,0 - 12,0 < 5xD 	VALUE TOOL	250-251		✓		
22 0402	Ø 3,0 - 20,0 < 5xD  <b>BEST SELLER</b>	MICRO GRAIN	254-255	✓		✓	
22 0403	Ø 3,0 - 12,0 H7 < 5xD 	MICRO GRAIN	256	✓		✓	
22 0404	Ø 3,0 - 12,0 < 5xD 	MICRO GRAIN	257-258	✓		✓	
22 0405	Ø 3,0 - 20,0 < 8xD  <b>BEST SELLER</b>	MICRO GRAIN	259-261	✓		✓	
22 0806	Ø 3,0 - 12,0 < 5xD 	VALUE TOOL	252-253		✓		
22 0406	Ø 3,0 - 18,0 < 12xD  <b>BEST SELLER</b>	MICRO GRAIN	262-263	✓		✓	
22 0409	Ø 3,0 - 16,0 < 8xD 	MICRO GRAIN	264-265	✓			
22 0410	Ø 3,0 - 16,0 < 5xD 	MICRO GRAIN	266	✓			
22 0412	Ø 3,0 - 16,0 < 5xD 	MICRO GRAIN	267	✓			
22 0419	Ø 3,0 - 12,0 H7 < 5xD 	MICRO GRAIN	269	✓			
22 0424	Ø 2,98 - 12,0 H7 < 5xD 	MICRO GRAIN	270	✓		✓	
22 0425	Ø 3,0 - 20,0 H7 < 8xD 	MICRO GRAIN	269	✓			
22 0468	Ø 0,3 - 14,0 	MICRO GRAIN	271				✓
22 0530	Ø 3,0 - 12,0 < 5xD 	MICRO GRAIN	240-241	✓			
Vollhartmetall Pilot-Stufenbohrer / Solid carbide pilot step drill							
22 0389	Ø 3,0 - 12,0 3xD 	MICRO GRAIN	242	✓		✓	
Vollhartmetall-, Hochleistungs- und Mehrfasen-Stufenbohrer für HSC-Bearbeitung / Solid carbide high capacity subland twist drill							
22 0471	M3 - M16 	MICRO GRAIN	272	✓		✓	
22 0473	M4 - M16 	MICRO GRAIN	272	✓		✓	

STAHL steel	INOX Edelstahl STAINLESS STEEL	INCONEL HASTELLOY TITANIUM	GJL	GJS	GTW GTS	NE METALLE non-ferrous	GRAPHIT graphite	COMPO- SITES	kurz- spanend short chip	lang- spanend long chip	MIT INNEN- KÜHLUNG with interior cooling	OHNE INNEN- KÜHLUNG without interior cooling	DIN 6535 Form HA	DIN 6535 Form HE	DIN 6535 Form HAK	DIN 6535 Form HEK
✓	✓		✓	✓	✓				✓			✓	✓			
✓	✓	✓	✓	✓	✓				✓		✓				✓	
✓	✓	✓	✓	✓	✓				✓			✓	✓			
						✓		✓		✓		✓	✓			
✓	✓		✓	✓	✓				✓		✓				✓	
						✓		✓		✓	✓				✓	
✓	✓		✓	✓	✓				✓							
✓	✓		✓	✓	✓				✓			✓		✓		
✓	✓		✓	✓	✓				✓		✓					
✓	✓		✓	✓	✓				✓		✓					✓
✓	✓		✓	✓	✓				✓		✓					
	✓	✓				✓				✓	✓				✓	
		✓								✓	✓				✓	
		✓								✓	✓				✓	
✓	✓		✓	✓	✓				✓			✓	✓			
✓	✓		✓	✓	✓				✓		✓				✓	
✓	✓		✓	✓	✓				✓		✓				✓	
✓			✓	✓	✓				✓			✓	✓			
						✓				✓	✓				✓	
✓			✓	✓	✓				✓			✓	✓			
✓																
✓	✓	✓	✓	✓	✓				✓			✓	✓			
✓	✓	✓	✓	✓	✓				✓		✓				✓	

1

2

3

4

5

6

7

8

i

9

## INHALTSVERZEICHNIS · TABLE OF CONTENTS

Art.	Vollhartmetallbohrer / Solid carbide drills		Material		HSC high-speed cutting	HRC < 50	HRC < 52	HRC 50-70
Vollhartmetallbohrer- Hochleistungsbohrer und Aufbohrer / Solid carbide twist drill / cordrill								
22 0520	Ø 3,0 - 12,0	< 10xD		MICRO GRAIN	273	✓		✓
22 0525	Ø 4,0 - 12,0	< 10xD		MICRO GRAIN	273	✓		✓
Vollhartmetallbohrer Diamantbeschichtet / Solid carbide twist drill with diamant coating								
22 0415	Ø 3,3 - 10,3	< 5xD		DIAMANT DIAMOND DCC 0312	284	✓		
Vollhartmetall Gewindefräser Diamantbeschichtet / Solid carbide thread milling cutter with diamant coating								
23 2005	M4 - M12	2,5xD		DCC 0318	285	✓		
23 2006	M4 - M12	2,0xD		DCC 0318	285	✓		
Hartgewindebohrer / High-hard machine taps								
22 2025	M3 - M12			MICRO GRAIN	282			✓
22 2215	MF8 - MF12			MICRO GRAIN	282			✓
22 2239	G1/8 - G1/4			MICRO GRAIN	283			✓
PKD-Hochleistungsbohrer / PCD drill								
29 0060	Ø 0,5 - 2,5	< 11xD		PKD PCD	284	✓		
22 0526	Ø 8,0 - 12,0	< 11xD		PKD PCD	280	✓		
Vollhartmetallbohrer für Composites / Solid carbide drills for composites								
29 0080A	Ø 3,0 - 12,0	< 4xD		DIAMANT DIAMOND DCA-06	286	✓		
29 0080B	Ø 3,0 - 12,0	< 4xD		MICRO GRAIN	286	✓		
29 0120	Ø 0,5 - 12,0			DCC 0318	288- 289	✓		
29 0121	Ø 2,8 - 5,9			DCC 0318	290	✓		
29 0122	Ø 6,0 - 12,0			DCC 0318	291	✓		

- Lagerware / Stock tool
- Keine Lagerware, Lieferzeit und Preis auf Anfrage  
No stock tool. Price and delivery on request
- ◻ Lieferzeit kurzfristig da Rohlinglager vorhanden  
Short delivery deadline possible then blanks are on stock available

- ⊘ Sonderpreis. Solange Vorrat reicht. Rückgabe nicht möglich.  
Special price. While stocks last. Return not possible.
- 2-3 2-3 Arbeitstage Lieferzeit / 2-3 work days delivery time

STAHL steel	INOX Edelstahl STAINLESS STEEL	INCONEL HASTELLOY TITANIUM	GJL	GJS	GTW GTS	NE METALLE non-ferrous	GRAPHIT graphite	COMPO- SITES	kurz- spanend short chip	lang- spanend long chip	MIT INNEN- KÜHLUNG with interior cooling	OHNE INNEN- KÜHLUNG without interior cooling	DIN 6535 Form HA	DIN 6535 Form HE	DIN 6535 Form HAK	DIN 6535 Form HEK	
✓			✓	✓	✓				✓			✓	✓				
✓			✓	✓	✓				✓		✓					✓	
							✓	✓	✓	✓	✓					✓	
						✓	✓	✓	✓			✓	✓				
						✓	✓	✓	✓			✓	✓				
			✓	✓	✓				✓			✓					
			✓	✓	✓				✓			✓					
			✓	✓	✓				✓			✓					
						✓	✓	✓	✓	✓		✓	✓				
						✓	✓	✓	✓		✓					✓	
							✓	✓	✓	✓		✓	✓				
								✓	✓	✓		✓	✓				
							✓	✓	✓	✓		✓	✓				
							✓	✓	✓	✓	✓					✓	



## 22 0321

Vollhartmetall-Micro-Pilot-Stufenbohrer 170°/90° abgestimmt auf Micro-Tieflochbohrer 22 0322  
Solid-carbide micro pilot step drill 170°/90°. Designed for micro deep hole drill 22 0322

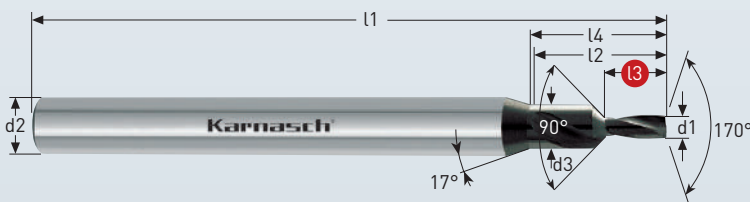

m7	Bohrungstoleranz Hole tolerance
	≤ 3

Art.	d1 m7	l3	l2	l4	l1	d3	d2 h6	€
22 0321 0080	• 0,80	<b>2,00</b>	4,7	5,2	50,0	1,7	4,0	70,00
22 0321 0085	• 0,85	<b>2,12</b>	4,8	5,3	50,0	1,7	4,0	70,00
22 0321 0090	• 0,90	<b>2,25</b>	4,9	5,4	50,0	1,7	4,0	70,00
22 0321 0095	• 0,95	<b>2,37</b>	5,0	5,5	50,0	1,7	4,0	70,00
22 0321 0100	• 1,00	<b>2,50</b>	5,6	6,1	55,0	2,0	4,0	70,00
22 0321 0105	• 1,05	<b>2,62</b>	5,7	6,2	55,0	2,0	4,0	70,00
22 0321 0110	• 1,10	<b>2,75</b>	5,9	6,4	55,0	2,0	4,0	70,00
22 0321 0115	• 1,15	<b>2,87</b>	6,0	6,5	55,0	2,0	4,0	70,00
22 0321 0120	• 1,20	<b>3,00</b>	6,1	6,6	55,0	2,0	4,0	70,00
22 0321 0125	• 1,25	<b>3,12</b>	7,1	7,6	55,0	2,5	4,0	70,00
22 0321 0130	• 1,30	<b>3,25</b>	7,2	7,7	55,0	2,5	4,0	70,00
22 0321 0135	• 1,35	<b>3,37</b>	7,3	7,8	55,0	2,5	4,0	70,00
22 0321 0140	• 1,40	<b>3,50</b>	7,4	7,9	55,0	2,5	4,0	70,00
22 0321 0145	• 1,45	<b>3,62</b>	7,5	8,0	55,0	2,5	4,0	70,00
22 0321 0150	• 1,50	<b>3,75</b>	8,6	9,1	55,0	3,0	4,0	70,00
22 0321 0155	• 1,55	<b>3,87</b>	8,7	9,2	55,0	3,0	4,0	70,00
22 0321 0160	• 1,60	<b>4,00</b>	8,8	9,3	55,0	3,0	4,0	70,00
22 0321 0165	• 1,65	<b>4,12</b>	8,9	9,4	55,0	3,0	4,0	70,00
22 0321 0170	• 1,70	<b>4,25</b>	9,1	9,6	55,0	3,0	4,0	70,00
22 0321 0175	• 1,75	<b>4,37</b>	9,2	9,7	55,0	3,0	4,0	70,00
22 0321 0180	• 1,80	<b>4,50</b>	10,1	10,6	55,0	3,5	4,0	70,00
22 0321 0185	• 1,85	<b>4,62</b>	10,3	10,8	55,0	3,5	4,0	70,00
22 0321 0190	• 1,90	<b>4,75</b>	10,4	10,9	55,0	3,5	4,0	70,00
22 0321 0195	• 1,95	<b>4,87</b>	10,5	11,0	55,0	3,5	4,0	70,00
22 0321 0200	• 2,00	<b>5,00</b>	10,6	11,1	65,0	3,5	6,0	75,00
22 0321 0205	• 2,05	<b>5,12</b>	10,7	11,2	65,0	3,5	6,0	75,00
22 0321 0210	• 2,10	<b>5,25</b>	10,8	11,3	65,0	3,5	6,0	75,00
22 0321 0215	• 2,15	<b>5,37</b>	10,9	11,4	65,0	3,5	6,0	75,00
22 0321 0220	• 2,20	<b>5,50</b>	12,8	13,3	65,0	4,5	6,0	75,00
22 0321 0225	• 2,25	<b>5,62</b>	12,9	13,4	65,0	4,5	6,0	75,00
22 0321 0230	• 2,30	<b>5,75</b>	13,0	13,5	65,0	4,5	6,0	75,00
22 0321 0235	• 2,35	<b>5,87</b>	13,1	13,6	65,0	4,5	6,0	75,00
22 0321 0240	• 2,40	<b>6,00</b>	13,2	13,7	65,0	4,5	6,0	75,00
22 0321 0245	• 2,45	<b>6,12</b>	13,4	13,9	65,0	4,5	6,0	75,00
22 0321 0250	• 2,50	<b>6,25</b>	13,5	14,0	65,0	4,5	6,0	75,00
22 0321 0255	• 2,55	<b>6,37</b>	13,6	14,1	65,0	4,5	6,0	75,00
22 0321 0260	• 2,60	<b>6,50</b>	13,7	14,2	65,0	4,5	6,0	75,00
22 0321 0265	• 2,65	<b>6,62</b>	14,7	15,2	65,0	5,0	6,0	75,00
22 0321 0270	• 2,70	<b>6,75</b>	14,8	15,3	65,0	5,0	6,0	75,00
22 0321 0275	• 2,75	<b>6,87</b>	14,9	15,4	65,0	5,0	6,0	75,00
22 0321 0280	• 2,80	<b>7,00</b>	15,0	15,5	65,0	5,0	6,0	75,00
22 0321 0285	• 2,85	<b>7,12</b>	15,1	15,6	65,0	5,0	6,0	75,00
22 0321 0290	• 2,90	<b>7,25</b>	15,2	15,7	65,0	5,0	6,0	75,00
22 0321 0295	• 2,95	<b>7,37</b>	15,4	15,9	65,0	5,0	6,0	75,00

<b>MICRO GRAIN</b>	KARNASCH NORM
<b>SPEZIAL SPECIAL</b>	DIN 6535 Form HA
	HSC HPC
	DVC-X2

Schnittdaten Cutting data	Film Movie	Zeichnungen Drawings
232		DXF/STEP

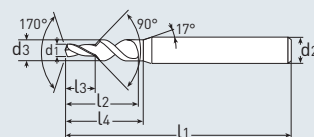
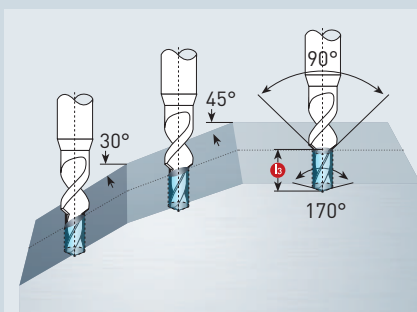

Richtwerte für den Einsatz der KARNASCH VHM-Hochleistungsbohrer ohne Innenkühlung  
Recommended cutting data for solid carbide twist drill, without interior cooling supply

Werkstoffe Work material	Werkstoffgruppe Material group	Bohrer Ø Festigkeit in N/mm²	Ø 0.80-0.85		Ø 0.86-0.99		Ø 1.0-2.95	
			Vc m/min	f mm/Umdr.	Vc m/min	f mm/Umdr.	Vc m/min	f mm/Umdr.
Baustahl Mild steel	1.1	≤ 600	50 (40-60)	0.02 (0.01-0.03)	50 (40-60)	0.03 (0.02-0.05)	50 (40-60)	0.08 (0.04-0.12)
Kohlenstoffstahl Legierter Stahl Carbon steel Alloy steel	1.2-2.1-2.2	600-950	50 (40-60)	0.02 (0.01-0.03)	50 (40-60)	0.03 (0.02-0.05)	50 (40-60)	0.08 (0.04-0.12)
	2.2-2.3-2.5-2.6	950-1200	50 (40-60)	0.02 (0.01-0.03)	50 (40-60)	0.03 (0.02-0.05)	50 (40-60)	0.08 (0.04-0.12)
Edelstahl Stainless steel	3.1	680	30 (20-40)	0.015 (0.008-0.02)	30 (20-40)	0.02 (0.01-0.03)	30 (20-40)	0.05 (0.02-0.10)
Guss Cast iron	7.1-7.2	≤ 105 HB	50 (40-60)	0.02 (0.01-0.03)	50 (40-60)	0.04 (0.02-0.06)	50 (40-60)	0.08 (0.04-0.12)
Kugelgraphitguss Ductile cast iron	7.4	≤ 133 HB	30 (20-40)	0.02 (0.01-0.03)	30 (20-40)	0.03 (0.02-0.05)	30 (20-40)	0.06 (0.02-0.10)

Qualitätsprodukte für die Metallbearbeitung.  
Quality products for metalworking.

## PROZESSSICHERHEIT FÜR PERFEKTE QUALITÄT IN SERIE

Process reliability for perfect quality  
in series production





## 22 0322

Mini-Vollhartmetall-Hochleistungsbohrer < 30×D  
Mini solid carbide twist drill < 30×D

STAHL  
steel  
< 1200 N/mm<sup>2</sup>

STAHL  
steel  
< 1500 N/mm<sup>2</sup>

INOX  
Edelstahl  
STAINLESS STEEL

INCONEL  
HASTELLOY  
TITANIUM

GJL

GJS

GTW  
GTS

kurz-  
spanend  
short chip

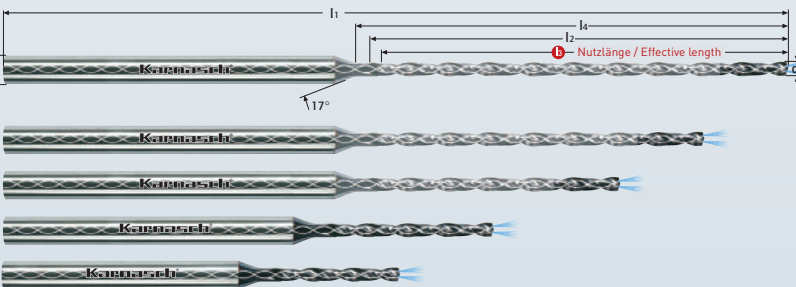

MICRO  
GRAIN

KARNASCH  
NORM

SPEZIAL  
SPECIAL

DIN 6535  
Form HAK



HSC  
HPC



DVC-X2<sup>2</sup>  
Nano-  
finish

Pilotbohrer Art. 22 0321 auf S. 232.  
Pilot drill art. 22 0321 on page 232.

Bohrertoleranz Drill tolerance
≤ 3,0
+ 0,000
- 0,010

Powerkammer  
Powerchamber

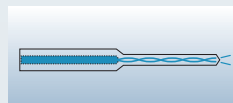

Vorteile / Advantages

- Erhöhter Kühlmittelaustritt auch bei niedrigem Druck
- Erhöhter Kühlmittelaustritt bei gleichem Druck
- Increased cooling pressure even at a lower pressure
- Increased cooling pressure at identical pressure

Die Aktuelle Produktion wird bis Ø 1,45 auf die Ausführung mit Powerkammer-Schaft umgestellt.  
The current production until Ø 1,45 will be changed in a shank with a powerchamber.

Schnittdaten  
Cutting data



1241

Film  
Movie



Zeichnungen  
Drawings



Art.	d1 h7	l3	l2	l4	l1	d2 h6	€
22 0322 0080 050	• 0,80	5	6	7	50	3	108,00
22 0322 0080 105	• 0,80	10,5	11	12	50	3	117,00
22 0322 0085 055	• 0,85	5,5	7	8	50	3	108,00
22 0322 0085 105	• 0,85	10,5	12	13	50	3	117,00
22 0322 0090 055	• 0,90	5,5	7	8	50	3	108,00
22 0322 0090 115	• 0,90	11,5	13	14	50	3	117,00
22 0322 0095 060	• 0,95	6	7	8	50	3	108,00
22 0322 0095 115	• 0,95	11,5	13	14	50	3	117,00
22 0322 0100 060	• 1,00	6	7	8	60	3	96,00
22 0322 0100 120	• 1,00	12	13	14	65	3	112,00
22 0322 0100 180	• 1,00	18	20	21	65	3	123,00
22 0322 0105 070	• 1,05	7	8	10	60	3	96,00
22 0322 0105 130	• 1,05	13	14	16	65	3	112,00
22 0322 0105 190	• 1,05	19	21	22	65	3	123,00
22 0322 0110 070	• 1,10	7	9	10	60	3	96,00
22 0322 0110 140	• 1,10	14	16	17	65	3	112,00
22 0322 0110 200	• 1,10	20	22	23	65	3	123,00
22 0322 0115 070	• 1,15	7	9	10	60	3	96,00
22 0322 0115 140	• 1,15	14	16	17	65	3	112,00
22 0322 0115 210	• 1,15	21	23	24	65	3	123,00
22 0322 0120 080	• 1,20	8	10	11	60	3	96,00
22 0322 0120 150	• 1,20	15	17	18	65	3	112,00
22 0322 0120 220	• 1,20	22	24	25	65	3	123,00
22 0322 0125 080	• 1,25	8	10	11	60	3	96,00
22 0322 0125 150	• 1,25	15	17	18	65	3	112,00
22 0322 0125 230	• 1,25	23	25	26	65	3	123,00
22 0322 0130 080	• 1,30	8	10	11	60	3	96,00
22 0322 0130 160	• 1,30	16	18	19	65	3	112,00
22 0322 0130 240	• 1,30	24	26	27	65	3	123,00
22 0322 0135 090	• 1,35	9	11	12	60	3	96,00
22 0322 0135 170	• 1,35	17	19	20	65	3	112,00
22 0322 0135 250	• 1,35	25	27	28	65	3	123,00
22 0322 0140 090	• 1,40	9	11	12	60	3	96,00
22 0322 0140 170	• 1,40	17	19	20	65	3	112,00
22 0322 0140 260	• 1,40	26	28	29	65	3	123,00
22 0322 0145 090	• 1,45	9	12	13	60	3	96,00
22 0322 0145 180	• 1,45	18	20	21	65	3	112,00
22 0322 0145 270	• 1,45	27	30	31	65	3	123,00
22 0322 0150 090	• 1,50	9	11	12	60	3	96,00
22 0322 0150 180	• 1,50	18	20	21	65	3	112,00
22 0322 0150 270	• 1,50	27	30	31	65	3	123,00
22 0322 0155 100	• 1,55	10	12	13	60	3	96,00
22 0322 0155 190	• 1,55	19	21	22	65	3	112,00
22 0322 0155 280	• 1,55	28	31	32	65	3	123,00

Art.	d1 h7	l3	l2	l4	l1	d2 h6	€
22 0322 0160 100	• 1,60	10	13	14	60	3	96,00
22 0322 0160 200	• 1,60	20	22	23	65	3	112,00
22 0322 0160 300	• 1,60	30	32	33	65	3	123,00
22 0322 0165 100	• 1,65	10	13	14	60	3	96,00
22 0322 0165 200	• 1,65	20	22	23	65	3	112,00
22 0322 0165 300	• 1,65	30	32	33	65	3	123,00
22 0322 0170 110	• 1,70	11	14	15	60	3	96,00
22 0322 0170 210	• 1,70	21	23	24	65	3	112,00
22 0322 0170 310	• 1,70	31	34	35	70	3	123,00
22 0322 0175 110	• 1,75	11	14	15	60	3	96,00
22 0322 0175 210	• 1,75	21	23	24	65	3	112,00
22 0322 0175 320	• 1,75	32	35	36	70	3	123,00
22 0322 0180 110	• 1,80	11	14	15	60	3	96,00
22 0322 0180 220	• 1,80	22	25	26	70	3	112,00
22 0322 0180 330	• 1,80	33	36	37	70	3	123,00
22 0322 0185 120	• 1,85	12	15	16	60	3	96,00
22 0322 0185 230	• 1,85	23	26	27	70	3	112,00
22 0322 0185 340	• 1,85	34	37	38	70	3	123,00
22 0322 0190 120	• 1,90	12	15	16	60	3	96,00
22 0322 0190 230	• 1,90	23	26	27	70	3	112,00
22 0322 0190 350	• 1,90	35	37	38	70	3	123,00
22 0322 0195 120	• 1,95	12	15	16	60	3	96,00
22 0322 0195 240	• 1,95	24	27	28	70	3	112,00
22 0322 0195 360	• 1,95	36	39	40	70	3	123,00
22 0322 0200 120	• 2,00	12	15	16	60	3	96,00
22 0322 0200 240	• 2,00	24	26	27	70	3	112,00
22 0322 0200 360	• 2,00	36	37	38	70	3	123,00
22 0322 0205 130	• 2,05	13	16	17	60	3	96,00
22 0322 0205 250	• 2,05	25	28	29	70	3	112,00
22 0322 0205 370	• 2,05	37	40	41	70	3	123,00
22 0322 0205 630	• 2,05	63	66	67	118	3	124,80
22 0322 0210 130	• 2,10	13	16	17	60	3	96,00
22 0322 0210 260	• 2,10	26	29	30	70	3	112,00
22 0322 0210 380	• 2,10	38	42	43	70	3	123,00
22 0322 0210 650	• 2,10	65	68	69	118	3	124,80
22 0322 0215 130	• 2,15	13	16	17	60	3	96,00
22 0322 0215 260	• 2,15	26	29	30	70	3	112,00
22 0322 0215 390	• 2,15	39	43	44	70	3	123,00
22 0322 0215 530	• 2,15	53	56	57	100	3	112,20
22 0322 0215 660	• 2,15	66	69	70	118	3	124,80
22 0322 0220 140	• 2,20	14	18	19	60	3	96,00
22 0322 0220 270	• 2,20	27	30	31	70	3	112,00
22 0322 0220 400	• 2,20	40	44	45	75	3	123,00
22 0322 0220 550	• 2,20	55	58	59	105	3	117,00

• Sonderpreis / Sale Artikel. Lieferbar solange Vorrat.  
Special price / sale article. While stocks last.

Art.	d1 h7	l3	l2	l4	l1	d2 h6	€
22 0322 0220 680	2,20	68	71	72	118	3	124,80
22 0322 0225 140	2,25	14	18	19	60	3	96,00
22 0322 0225 270	2,25	27	30	31	70	3	112,00
22 0322 0225 410	2,25	41	44	45	75	3	123,00
22 0322 0225 570	2,25	57	60	61	105	3	117,00
22 0322 0225 690	2,25	69	72	73	118	3	124,80
22 0322 0230 140	2,30	14	18	19	60	3	96,00
22 0322 0230 280	2,30	28	31	32	70	3	112,00
22 0322 0230 420	2,30	42	45	46	82	3	123,00
22 0322 0230 570	2,30	57	60	61	105	3	117,00
22 0322 0230 710	2,30	71	74	75	118	3	124,80
22 0322 0235 150	2,35	15	19	20	60	3	96,00
22 0322 0235 290	2,35	29	32	33	70	3	112,00
22 0322 0235 430	2,35	43	46	48	82	3	123,00
22 0322 0235 590	2,35	59	62	63	105	3	117,00
22 0322 0235 730	2,35	73	76	77	120	3	124,80
22 0322 0240 150	2,40	15	19	20	60	3	96,00
22 0322 0240 290	2,40	29	32	33	70	3	112,00
22 0322 0240 440	2,40	44	47	48	82	3	123,00
22 0322 0240 600	2,40	60	63	64	105	3	117,00
22 0322 0240 750	2,40	75	78	79	120	3	124,80
22 0322 0245 150	2,45	15	19	20	60	3	96,00
22 0322 0245 300	2,45	30	33	34	70	3	112,00
22 0322 0245 450	2,45	45	49	50	82	3	123,00
22 0322 0245 620	2,45	62	65	66	105	3	117,00
22 0322 0245 760	2,45	76	79	80	120	3	124,80
22 0322 0250 150	2,50	15	19	20	60	3	96,00
22 0322 0250 300	2,50	30	33	34	70	3	112,00
22 0322 0250 450	2,50	45	49	50	82	3	123,00
22 0322 0250 770	2,50	77	80	81	120	3	124,80
22 0322 0255 160	2,55	16	20	21	60	3	96,00
22 0322 0255 310	2,55	31	35	36	75	3	112,00
22 0322 0255 460	2,55	46	50	53	82	3	123,00
22 0322 0255 670	2,55	67	70	71	120	3	121,20
22 0322 0255 790	2,55	79	82	83	130	3	129,60
22 0322 0260 160	2,60	16	20	21	60	3	96,00
22 0322 0260 320	2,60	32	36	37	75	3	112,00
22 0322 0260 470	2,60	47	52	53	82	3	123,00
22 0322 0260 670	2,60	67	71	72	120	3	121,20
22 0322 0260 800	2,60	80	84	85	130	3	129,60

Art.	d1 h7	l3	l2	l4	l1	d2 h6	€
22 0322 0265 160	2,65	16	20	21	60	3	96,00
22 0322 0265 320	2,65	32	36	37	75	3	112,00
22 0322 0265 480	2,65	48	53	54	82	3	123,00
22 0322 0265 680	2,65	68	72	73	120	3	121,20
22 0322 0265 810	2,65	81	85	86	130	3	129,60
22 0322 0270 170	2,70	17	21	22	60	3	96,00
22 0322 0270 330	2,70	33	37	38	75	3	112,00
22 0322 0270 490	2,70	49	54	55	90	3	123,00
22 0322 0270 690	2,70	69	73	74	120	3	121,20
22 0322 0270 830	2,70	83	87	88	130	3	129,60
22 0322 0275 170	2,75	17	21	22	60	3	96,00
22 0322 0275 330	2,75	33	37	38	75	3	112,00
22 0322 0275 500	2,75	50	54	56	90	3	123,00
22 0322 0275 710	2,75	71	75	76	120	3	121,20
22 0322 0275 850	2,75	85	89	90	130	3	129,60
22 0322 0280 170	2,80	17	21	22	60	3	96,00
22 0322 0280 340	2,80	34	38	39	75	3	112,00
22 0322 0280 530	2,80	53	57	58	90	3	123,00
22 0322 0280 720	2,80	72	76	77	120	3	121,20
22 0322 0280 860	2,80	86	90	91	130	3	129,60
22 0322 0285 180	2,85	18	23	24	60	3	96,00
22 0322 0285 350	2,85	35	39	40	75	3	112,00
22 0322 0285 530	2,85	53	57	58	90	3	123,00
22 0322 0285 730	2,85	73	77	78	120	3	121,20
22 0322 0285 880	2,85	88	92	93	130	3	129,60
22 0322 0290 180	2,90	18	23	24	60	3	96,00
22 0322 0290 350	2,90	35	39	40	75	3	112,00
22 0322 0290 530	2,90	53	57	58	90	3	123,00
22 0322 0290 740	2,90	74	78	79	120	3	121,20
22 0322 0290 890	2,90	89	93	94	130	3	129,60
22 0322 0295 180	2,95	18	23	24	60	3	96,00
22 0322 0295 360	2,95	36	40	41	75	3	112,00
22 0322 0295 540	2,95	54	58	59	90	3	123,00
22 0322 0295 740	2,95	74	78	79	120	3	121,20
22 0322 0295 890	2,95	89	93	94	130	3	129,60

> Ø 2,95 = Art. 22 0390 auf Seite / on page 244-245  
 % Sonderpreis / Sale Artikel. Lieferbar solange Vorrat.  
 Special price / sale article. White stocks last.

### HSC- und HPC-Vollhartmetall-Minibohrer mit Innenkühlung

Ø 0,8 - 0,95 mm 6xD-12xD  
 Ø 1,0 - 2,95 mm 6xD-12xD-18xD

### HSC- and HPC-solid carbide mini drill with interior cooling supply

Ø 0,8 - 0,95 mm 6xD-12xD  
 Ø 1,0 - 2,95 mm 6xD-12xD-18xD

- Neue Perspektive durch Innenkühlung ab 0,8 Ø mm  
6xD – 12xD – 18xD  
New perspective through interior cooling supply from 0,8 Ø mm  
6xD – 12xD – 18xD
- Reduzierte Taktzeiten  
Reduced cycle-times
- Überlegene Leistung  
Superior performance
- Weltweit einmalige Ausführung  
Worldwide unique version
- Prozesssicher  
Process reliability

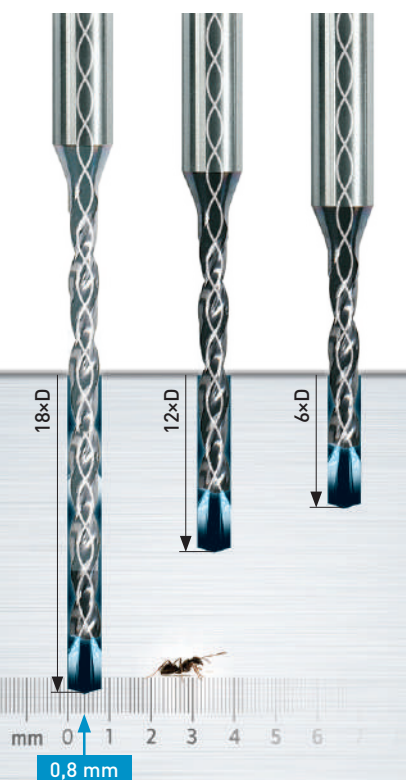

22 0341

Vollhartmetall-Hochleistungs-Minidrill – HSC/HHC < 10×D  
Solid carbide-micro-twist drill – HSC/HHC < 10×D

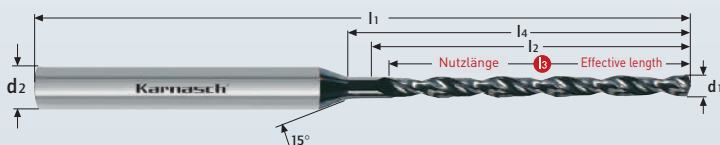

k5	Bohrertoleranz Drill tolerance	h6	Bohrertoleranz Drill tolerance
≅ 3,0	+ 0,004 - 0,000	≅ 3,0	0,000 - 0,006

<b>MICRO GRAIN</b>	KARNASCH NORM
N/M	DIN 6535 Form HA
	<b>HSC HPC</b>
	<b>DVC-X2<sup>2</sup> Nano-finish</b>
	MMKS

Schnittdaten Cutting data	Zeichnungen Drawings
1251	DXF/STEP

Art.	d1 k5	l3	l2	l4	l1	d2 h6	€
22 0341 0010 005	• 0,10	0,5	1,5	2,0	38	3,0	53,00
22 0341 0015 006	• 0,15	0,6	1,8	2,0	38	3,0	30,60
22 0341 0015 0075	• 0,15	0,75	1,8	2,0	38	3,0	53,00
22 0341 0020 008	• 0,20	0,8	1,8	2,3	38	3,0	54,00
22 0341 0020 012	• 0,20	1,2	2,2	2,7	38	3,0	54,00
22 0341 0025 010	• 0,25	1,0	2,0	2,5	38	3,0	54,00
22 0341 0025 015	• 0,25	1,5	2,5	3,0	38	3,0	54,00
22 0341 0030 012	• 0,30	1,2	2,2	2,7	38	3,0	54,00
22 0341 0030 018	• 0,30	1,8	2,8	3,3	38	3,0	54,00
22 0341 0035 014	• 0,35	1,4	2,4	2,9	38	3,0	54,00
22 0341 0035 021	• 0,35	2,1	3,1	3,6	38	3,0	54,00
22 0341 0040 016	• 0,40	1,6	2,6	3,1	38	3,0	54,00
22 0341 0040 024	• 0,40	2,4	3,4	3,9	38	3,0	54,00
22 0341 0045 018	• 0,45	1,8	2,8	3,3	38	3,0	54,00
22 0341 0045 027	• 0,45	2,7	3,7	4,2	38	3,0	54,00
22 0341 0050 020	• 0,50	2,0	3,0	3,5	38	3,0	54,00
22 0341 0050 030	• 0,50	3,0	4,0	4,5	38	3,0	54,00
22 0341 0050 060	• 0,50 h6	6,0	8,0	8,5	38	3,0	54,00
22 0341 0055 022	• 0,55	2,2	3,2	3,7	38	3,0	54,00
22 0341 0055 033	• 0,55	3,3	4,3	4,8	38	3,0	54,00
22 0341 0060 024	• 0,60	2,4	3,4	3,9	38	3,0	54,00
22 0341 0060 036	• 0,60	3,6	4,6	5,1	38	3,0	54,00
22 0341 0060 060	• 0,60 h6	6,0	8,0	8,5	38	3,0	54,00
22 0341 0065 026	• 0,65	2,6	3,6	4,1	38	3,0	54,00
22 0341 0065 039	• 0,65	3,9	4,9	5,4	38	3,0	54,00
22 0341 0070 028	• 0,70	2,8	3,8	4,3	38	3,0	54,00
22 0341 0070 042	• 0,70	4,2	5,2	5,7	38	3,0	54,00
22 0341 0070 080	• 0,70 h6	8,0	10,0	10,5	38	3,0	54,00
22 0341 0075 030	• 0,75	3,0	4,0	4,5	38	3,0	54,00
22 0341 0075 045	• 0,75	4,5	5,5	6,0	38	3,0	54,00
22 0341 0080 032	• 0,80	3,2	4,8	5,3	46	3,0	53,00
22 0341 0080 048	• 0,80	4,8	5,8	6,3	54	3,0	53,00
22 0341 0080 080	• 0,80 h6	8,0	10,0	10,5	38	3,0	53,00
22 0341 0085 034	• 0,85	3,4	5,1	5,6	46	3,0	53,00
22 0341 0085 051	• 0,85	5,1	6,1	6,6	54	3,0	53,00
22 0341 0090 036	• 0,90	3,6	5,4	5,9	46	3,0	53,00
22 0341 0090 054	• 0,90	5,4	6,5	6,7	54	3,0	53,00
22 0341 0090 100	• 0,90 h6	10,0	12,0	12,5	38	3,0	53,00
22 0341 0095 038	• 0,95	3,8	5,7	6,2	46	3,0	53,00
22 0341 0095 057	• 0,95	5,7	6,8	7,3	54	3,0	53,00
22 0341 0100 040	• 1,00	4,0	6,0	6,5	46	3,0	53,00
22 0341 0100 060	• 1,00	6,0	7,2	7,7	54	3,0	53,00
22 0341 0100 100	• 1,00 h6	10,0	12,0	12,5	38	3,0	53,00
22 0341 0105 042	• 1,05	4,2	6,3	6,8	46	3,0	53,00
22 0341 0105 063	• 1,05	6,3	7,6	8,1	54	3,0	53,00
22 0341 0110 044	• 1,10	4,4	6,6	7,1	46	3,0	53,00
22 0341 0110 066	• 1,10	6,6	7,9	8,4	54	3,0	53,00
22 0341 0110 160	• 1,10 h6	16,0	20,0	20,5	50	3,0	53,00
22 0341 0115 046	• 1,15	4,6	6,9	7,4	46	3,0	53,00
22 0341 0115 069	• 1,15	6,9	8,3	8,8	54	3,0	53,00
22 0341 0120 048	• 1,20	4,8	7,2	7,7	46	3,0	53,00
22 0341 0120 072	• 1,20	7,2	8,6	9,1	54	3,0	53,00

Vollhartmetall-Hochleistungs-Minidrill – HSC/HHC < 10xD  
Solid carbide-micro-twist drill – HSC/HHC < 10xD

22 0341

Art.	d1 k5	l3	l2	l4	l1	d2 h6	€
22 0341 0120 160	• 1,20 h6	16,0	20,0	20,5	50	3,0	53,00
22 0341 0125 050	• 1,25	5,0	7,5	8,0	46	3,0	53,00
22 0341 0125 075	• 1,25	7,5	8,9	9,5	54	3,0	53,00
22 0341 0130 052	• 1,30	5,2	7,8	8,3	46	3,0	53,00
22 0341 0130 078	• 1,30	7,8	9,4	9,9	54	3,0	53,00
22 0341 0130 160	• 1,30 h6	16,0	20,0	20,5	50	3,0	53,00
22 0341 0135 054	• 1,35	5,4	8,1	8,6	46	3,0	53,00
22 0341 0135 081	• 1,35	8,1	9,7	10,2	54	3,0	53,00
22 0341 0140 056	• 1,40	5,6	8,4	8,9	46	3,0	53,00
22 0341 0140 084	• 1,40	8,4	10,1	10,6	54	3,0	53,00
22 0341 0140 160	• 1,40 h6	16,0	20,0	20,5	50	3,0	53,00
22 0341 0145 058	• 1,45	5,8	8,7	9,2	46	3,0	53,00
22 0341 0145 087	• 1,45	8,7	10,4	10,9	54	3,0	53,00
22 0341 0150 060	• 1,50	6,0	9,0	9,5	46	3,0	53,00
22 0341 0150 090	• 1,50	9,0	10,8	11,3	54	3,0	53,00
22 0341 0150 160	• 1,50 h6	16,0	20,0	20,5	50	3,0	53,00
22 0341 0155 062	• 1,55	6,2	7,4	7,9	46	3,0	53,00
22 0341 0155 093	• 1,55	9,3	11,2	11,7	54	3,0	53,00
22 0341 0160 064	• 1,60	6,4	7,7	8,2	46	3,0	53,00
22 0341 0160 096	• 1,60	9,6	11,5	12,0	54	3,0	53,00
22 0341 0160 220	• 1,60 h6	22,0	30,0	30,5	66	3,0	53,00
22 0341 0165 066	• 1,65	6,6	7,9	8,4	46	3,0	53,00
22 0341 0165 099	• 1,65	9,9	11,9	12,4	54	3,0	53,00
22 0341 0170 068	• 1,70	6,8	8,2	8,7	46	3,0	53,00
22 0341 0170 102	• 1,70	10,2	12,2	12,7	54	3,0	53,00
22 0341 0170 220	• 1,70 h6	22,0	30,0	30,5	66	3,0	53,00
22 0341 0175 070	• 1,75	7,0	8,4	8,9	46	3,0	53,00
22 0341 0175 105	• 1,75	10,5	12,6	13,1	54	3,0	53,00
22 0341 0180 072	• 1,80	7,2	8,6	9,1	46	3,0	53,00
22 0341 0180 108	• 1,80	10,8	13,0	13,5	54	3,0	53,00
22 0341 0180 220	• 1,80 h6	22,0	30,0	30,5	66	3,0	53,00
22 0341 0185 074	• 1,85	7,4	8,9	9,4	46	3,0	53,00
22 0341 0185 111	• 1,85	11,1	13,3	13,8	54	3,0	53,00
22 0341 0190 076	• 1,90	7,6	9,1	9,6	46	3,0	53,00
22 0341 0190 114	• 1,90	11,4	13,7	14,2	54	3,0	53,00
22 0341 0190 220	• 1,90 h6	22,0	30,0	30,5	66	3,0	53,00
22 0341 0195 078	• 1,95	7,8	9,4	9,9	46	3,0	53,00
22 0341 0195 117	• 1,95	11,7	14,0	14,5	54	3,0	53,00
22 0341 0200 080	• 2,00	8,0	12,0	12,5	60	4,0	53,00
22 0341 0200 120	• 2,00	12,0	14,4	14,9	65	4,0	53,00
22 0341 0200 220	• 2,00 h6	22,0	30,0	30,5	66	3,0	53,00
22 0341 0205 082	• 2,05	8,2	12,3	12,8	60	4,0	53,00
22 0341 0205 123	• 2,05	12,3	14,7	15,2	65	4,0	53,00
22 0341 0210 084	• 2,10	8,4	12,6	13,1	60	4,0	53,00
22 0341 0210 126	• 2,10	12,6	15,1	15,6	65	4,0	53,00
22 0341 0210 250	• 2,10 h6	25,0	35,0	35,5	74	3,0	53,00
22 0341 0215 086	• 2,15	8,6	12,9	13,4	60	4,0	53,00
22 0341 0215 129	• 2,15	12,9	15,5	16,0	65	4,0	53,00
22 0341 0220 088	• 2,20	8,8	13,2	13,7	60	4,0	53,00
22 0341 0220 132	• 2,20	13,2	15,8	16,3	65	4,0	53,00
22 0341 0220 250	• 2,20 h6	25,0	35,0	35,5	74	3,0	53,00
22 0341 0225 090	• 2,25	9,0	13,5	14,0	60	4,0	53,00
22 0341 0225 135	• 2,25	13,5	16,2	16,7	65	4,0	53,00
22 0341 0230 092	• 2,30	9,2	13,8	14,3	60	4,0	53,00
22 0341 0230 138	• 2,30	13,8	16,6	17,1	65	4,0	53,00
22 0341 0230 250	• 2,30 h6	25,0	35,0	35,5	74	3,0	53,00
22 0341 0235 094	• 2,35	9,4	14,1	14,6	60	4,0	53,00
22 0341 0235 141	• 2,35	14,1	16,9	17,4	65	4,0	53,00
22 0341 0240 096	• 2,40	9,6	14,4	14,9	60	4,0	53,00
22 0341 0240 144	• 2,40	14,4	17,2	17,7	65	4,0	53,00
22 0341 0240 250	• 2,40 h6	25,0	35,0	35,5	74	3,0	53,00
22 0341 0245 098	• 2,45	9,8	14,7	15,2	60	4,0	53,00
22 0341 0245 147	• 2,45	14,7	17,6	18,1	65	4,0	53,00
22 0341 0250 100	• 2,50	10,0	15,0	15,5	60	4,0	53,00
22 0341 0250 150	• 2,50	15,0	18,0	18,5	65	4,0	53,00
22 0341 0250 250	• 2,50 h6	25,0	35,0	35,5	74	3,0	53,00
22 0341 0255 102	• 2,55	10,2	15,3	15,7	60	4,0	53,00
22 0341 0255 153	• 2,55	15,3	18,5	19,0	65	4,0	53,00
22 0341 0260 104	• 2,60	10,4	15,6	16,1	60	4,0	53,00
22 0341 0260 156	• 2,60	15,6	18,7	19,2	65	4,0	53,00
22 0341 0260 320	• 2,60 h6	32,0	40,0	40,5	82	3,0	53,00
22 0341 0265 106	• 2,65	10,6	15,9	16,4	60	4,0	53,00
22 0341 0265 159	• 2,65	15,9	19,1	19,6	65	4,0	53,00
22 0341 0270 108	• 2,70	10,8	16,2	16,7	60	4,0	53,00
22 0341 0270 162	• 2,70	16,2	19,4	19,9	65	4,0	53,00
22 0341 0270 320	• 2,70 h6	32,0	40,0	40,5	82	3,0	53,00
22 0341 0275 110	• 2,75	11,0	16,5	17,0	60	4,0	53,00
22 0341 0275 165	• 2,75	16,5	19,8	20,3	65	4,0	53,00
22 0341 0280 112	• 2,80	11,2	16,8	17,3	60	4,0	53,00
22 0341 0280 168	• 2,80	16,8	20,2	20,7	65	4,0	53,00
22 0341 0280 320	• 2,80 h6	32,0	40,0	40,5	82	3,0	53,00
22 0341 0285 114	• 2,85	11,4	17,1	17,6	60	4,0	53,00
22 0341 0285 171	• 2,85	17,1	20,5	21,0	65	4,0	53,00
22 0341 0290 116	• 2,90	11,6	17,4	17,9	60	4,0	53,00
22 0341 0290 174	• 2,90	17,4	20,9	21,4	65	4,0	53,00
22 0341 0290 320	• 2,90 h6	32,0	40,0	40,5	82	3,0	53,00
22 0341 0295 118	• 2,95	11,8	17,7	18,2	60	4,0	53,00
22 0341 0295 177	• 2,95	17,7	21,2	21,7	65	4,0	53,00
22 0341 0300 120	• 3,00	12,0	18,0	18,5	60	4,0	53,00
22 0341 0300 180	• 3,00	18,0	21,6	22,1	65	4,0	53,00

% Sonderpreis / Sale Artikel. Lieferbar solange Vorrat. Special price / sale article. While stocks last.



SPATENBOHRER  
siehe Seite 303-356

SPADE DRILLS  
see page 303-356



1



2



3



4



5



6



7



8



9

Index



Mini-Vollhartmetall-Hochleistungsbohrer  
Mini solid carbide twist drill

22 0360

- Alu-  
minium**
- Aluminium  
< 6% Si
- MESSING**  
brass
- Kupfer**  
copper
- Gold**  
gold
- Kunststoff**  
plastic

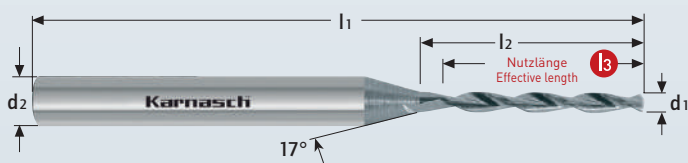

h7	Bohrertoleranz Drill tolerance	Über 6% Si bis 12% Si empfehlen wir unsere NHC-7000-Beschichtung Over 6% Si until 12% Si we recommend our NHC-7000-coating
	≤ 3,0	

<b>MICRO GRAIN</b>	<b>KARNASCH NORM</b>
<b>W</b>	<b>DIN 6535 Form HA</b>
	<b>HSC High-Speed-Cutting</b>
	<b>POLIERT POLISHED</b>

Art.	d1 h7	l3	l2	l1	d2 h6	€
22 0360 0050 050	• 0,50	5	6,5	39	3	19,50
22 0360 0055 050	• 0,55	5	6,5	39	3	19,50
22 0360 0060 050	• 0,60	5	6,5	39	3	19,50
22 0360 0065 060	• 0,65	6	7,5	39	3	19,50
22 0360 0070 060	• 0,70	6	7,5	39	3	19,50
22 0360 0075 080	• 0,75	8	9,5	39	3	19,50
22 0360 0080 080	• 0,80	8	9,5	39	3	19,50
22 0360 0085 080	• 0,85	8	9,5	39	3	19,50
22 0360 0090 100	• 0,90	10	11,5	39	3	19,50
22 0360 0095 100	• 0,95	10	11,5	39	3	19,50
22 0360 0100 100	• 1,00	10	11,5	39	3	19,50
22 0360 0105 100	• 1,05	10	11,5	39	3	19,50
22 0360 0110 100	• 1,10	10	11,5	39	3	19,50
22 0360 0115 100	• 1,15	10	11,5	39	3	19,50
22 0360 0120 120	• 1,20	12	14,5	39	3	19,50
22 0360 0125 120	• 1,25	12	14,5	39	3	19,50
22 0360 0130 120	• 1,30	12	14,5	39	3	19,50
22 0360 0135 120	• 1,35	12	14,5	39	3	19,50
22 0360 0140 120	• 1,40	12	14,5	39	3	19,50
22 0360 0145 120	• 1,45	12	14,5	39	3	19,50
22 0360 0150 120	• 1,50	12	14,5	39	3	19,50
22 0360 0160 120	• 1,60	12	14,5	39	3	19,50
22 0360 0165 120	• 1,65	12	14,5	39	3	19,50
22 0360 0170 120	• 1,70	12	14,5	39	3	19,50
22 0360 0180 120	• 1,80	12	14,5	39	3	19,50
22 0360 0185 120	• 1,85	12	14,5	39	3	19,50
22 0360 0190 120	• 1,90	12	14,5	39	3	19,50
22 0360 0200 140	• 2,00	14	16,5	39	3	19,50
22 0360 0205 140	• 2,05	14	16,5	39	3	19,50
22 0360 0210 140	• 2,10	14	16,5	39	3	19,50
22 0360 0220 140	• 2,20	14	16,5	39	3	19,50
22 0360 0230 140	• 2,30	14	16,5	39	3	19,50
22 0360 0240 140	• 2,40	14	16,5	39	3	19,50
22 0360 0250 140	• 2,50	14	16,5	39	3	19,50
22 0360 0260 140	• 2,60	14	16,5	39	3	19,50
22 0360 0270 140	• 2,70	14	16,5	39	3	19,50
22 0360 0280 140	• 2,80	14	16,5	39	3	19,50
22 0360 0290 140	• 2,90	14	16,5	39	3	19,50
22 0360 0300 140	• 3,00	14	16,5	39	3	19,50

Schnittdaten Cutting data	Zeichnungen Drawings
1253	DXF/STEP

- 1
- 2
- 3
- 4
- 5
- 6
- 7
- 8
- 9

Index

## 22 0530

Vollhartmetall-Hochleistungsflachkopfbohrer für Aluminium  
Solid carbide shallow drill 180° for aluminum

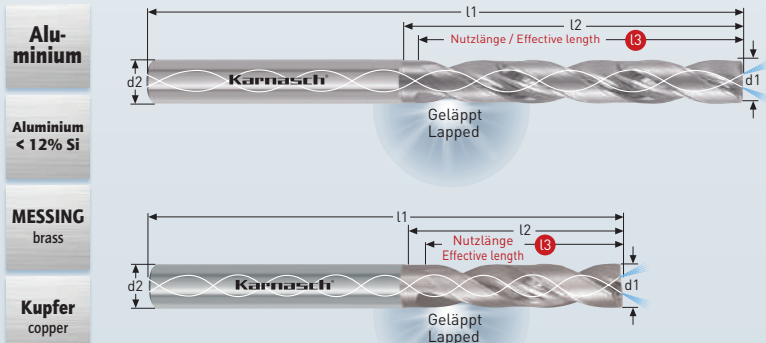

- Aluminium**
- Aluminium < 12% Si
- MESSING**  
brass
- Kupfer**  
copper
- Kunststoff**  
plastic

<b>MICRO GRAIN</b>	<b>KARNASCH NORM</b>
<b>W</b>	<b>DIN 6535 Form HAK</b>
	<b>HSC HPC</b>
	<b>GELÄPPT LAPPED</b>



Schnittdaten  
Cutting data

Zeichnungen  
Drawings

**i** 1242

**DXF/STEP**

Art.	d1 m7	<b>l3</b>	l2	l1	d2 h6	€
22 0530 0300 014	• 3,00	14	20	62	6,0	91,00
22 0530 0300 023	• 3,00	23	28	66	6,0	109,00
22 0530 0320 014	• 3,20	14	20	62	6,0	91,00
22 0530 0320 023	• 3,20	23	28	66	6,0	109,00
22 0530 0330 014	• 3,30	14	20	62	6,0	91,00
22 0530 0330 023	• 3,30	23	28	66	6,0	109,00
22 0530 0340 014	• 3,40	14	20	62	6,0	91,00
22 0530 0340 023	• 3,40	23	28	66	6,0	109,00
22 0530 0350 014	• 3,50	14	20	62	6,0	91,00
22 0530 0350 023	• 3,50	23	28	66	6,0	109,00
22 0530 0370 017	• 3,70	17	20	62	6,0	91,00
22 0530 0370 023	• 3,70	23	28	66	6,0	109,00
22 0530 0380 017	• 3,80	17	24	66	6,0	91,00
22 0530 0380 029	• 3,80	29	36	74	6,0	109,00
22 0530 0390 017	• 3,90	17	24	66	6,0	91,00
22 0530 0390 029	• 3,90	29	36	74	6,0	109,00
22 0530 0400 017	• 4,00	17	24	66	6,0	91,00
22 0530 0400 029	• 4,00	29	36	74	6,0	109,00
22 0530 0420 017	• 4,20	17	24	66	6,0	91,00
22 0530 0420 029	• 4,20	29	36	74	6,0	109,00
22 0530 0430 017	• 4,30	17	24	66	6,0	91,00
22 0530 0430 029	• 4,30	29	36	74	6,0	109,00
22 0530 0450 017	• 4,50	17	24	66	6,0	91,00
22 0530 0450 029	• 4,50	29	36	74	6,0	109,00
22 0530 0465 017	• 4,65	17	24	66	6,0	91,00
22 0530 0465 029	• 4,65	29	36	74	6,0	109,00
22 0530 0480 020	• 4,80	20	28	66	6,0	91,00
22 0530 0480 035	• 4,80	35	44	82	6,0	109,00
22 0530 0500 020	• 5,00	20	28	66	6,0	91,00
22 0530 0500 035	• 5,00	35	44	82	6,0	109,00
22 0530 0510 020	• 5,10	20	28	66	6,0	91,00
22 0530 0510 035	• 5,10	35	44	82	6,0	109,00
22 0530 0520 020	• 5,20	20	28	66	6,0	91,00
22 0530 0520 035	• 5,20	35	44	82	6,0	109,00
22 0530 0530 020	• 5,30	20	28	66	6,0	91,00
22 0530 0530 035	• 5,30	35	44	82	6,0	109,00
22 0530 0540 020	• 5,40	20	28	66	6,0	91,00
22 0530 0540 035	• 5,40	35	44	82	6,0	109,00
22 0530 0550 020	• 5,50	20	28	66	6,0	91,00
22 0530 0550 035	• 5,50	35	44	82	6,0	109,00
22 0530 0555 020	• 5,55	20	28	66	6,0	91,00
22 0530 0555 035	• 5,55	35	44	82	6,0	109,00
22 0530 0560 020	• 5,60	20	28	66	6,0	91,00
22 0530 0560 035	• 5,60	35	44	82	6,0	109,00
22 0530 0570 020	• 5,70	20	28	66	6,0	91,00
22 0530 0570 035	• 5,70	35	44	82	6,0	109,00
22 0530 0580 020	• 5,80	20	28	66	6,0	91,00
22 0530 0580 035	• 5,80	35	44	82	6,0	109,00

Art.	d1 m7	<b>l3</b>	l2	l1	d2 h6	€
22 0530 0600 020	• 6,00	20	28	66	6,0	91,00
22 0530 0600 035	• 6,00	35	44	82	6,0	109,00
22 0530 0610 024	• 6,10	24	34	79	8,0	112,00
22 0530 0610 043	• 6,10	43	53	91	8,0	121,00
22 0530 0620 024	• 6,20	24	34	79	8,0	112,00
22 0530 0620 043	• 6,20	43	53	91	8,0	121,00
22 0530 0630 024	• 6,30	24	34	79	8,0	112,00
22 0530 0630 043	• 6,30	43	53	91	8,0	121,00
22 0530 0640 024	• 6,40	24	34	79	8,0	112,00
22 0530 0640 043	• 6,40	43	53	91	8,0	121,00
22 0530 0650 024	• 6,50	24	34	79	8,0	112,00
22 0530 0650 043	• 6,50	43	53	91	8,0	121,00
22 0530 0660 024	• 6,60	24	34	79	8,0	112,00
22 0530 0660 043	• 6,60	43	53	91	8,0	121,00
22 0530 0670 024	• 6,70	24	34	79	8,0	112,00
22 0530 0670 043	• 6,70	43	53	91	8,0	121,00
22 0530 0680 024	• 6,80	24	34	79	8,0	112,00
22 0530 0680 043	• 6,80	43	53	91	8,0	121,00
22 0530 0690 024	• 6,90	24	34	79	8,0	112,00
22 0530 0690 043	• 6,90	43	53	91	8,0	121,00
22 0530 0700 024	• 7,00	24	34	79	8,0	112,00
22 0530 0700 043	• 7,00	43	53	91	8,0	121,00
22 0530 0710 029	• 7,10	29	41	79	8,0	112,00
22 0530 0710 043	• 7,10	43	53	91	8,0	121,00
22 0530 0720 029	• 7,20	29	41	79	8,0	112,00
22 0530 0720 043	• 7,20	43	53	91	8,0	121,00
22 0530 0730 029	• 7,30	29	41	79	8,0	112,00
22 0530 0730 043	• 7,30	43	53	91	8,0	121,00
22 0530 0740 029	• 7,40	29	41	79	8,0	112,00
22 0530 0740 043	• 7,40	43	53	91	8,0	121,00
22 0530 0750 029	• 7,50	29	41	79	8,0	112,00
22 0530 0750 043	• 7,50	43	53	91	8,0	121,00
22 0530 0760 029	• 7,60	29	41	79	8,0	112,00
22 0530 0760 043	• 7,60	43	53	91	8,0	121,00
22 0530 0780 029	• 7,80	29	41	79	8,0	112,00
22 0530 0780 043	• 7,80	43	53	91	8,0	121,00
22 0530 0790 029	• 7,90	29	41	79	8,0	112,00
22 0530 0790 043	• 7,90	43	53	91	8,0	121,00
22 0530 0800 029	• 8,00	29	41	79	8,0	112,00
22 0530 0800 043	• 8,00	43	53	91	8,0	121,00
22 0530 0810 035	• 8,10	35	47	89	10,0	151,00
22 0530 0810 049	• 8,10	49	61	103	10,0	173,00
22 0530 0820 035	• 8,20	35	47	89	10,0	151,00
22 0530 0820 049	• 8,20	49	61	103	10,0	173,00
22 0530 0830 035	• 8,30	35	47	89	10,0	151,00
22 0530 0830 049	• 8,30	49	61	103	10,0	173,00
22 0530 0840 035	• 8,40	35	47	89	10,0	151,00
22 0530 0840 049	• 8,40	49	61	103	10,0	173,00

Art.	d1 m7	l3	l2	l1	d2 h6	€
22 0530 0850 035	• 8,50	35	47	89	10,0	151,00
22 0530 0850 049	• 8,50	49	61	103	10,0	173,00
22 0530 0860 035	• 8,60	35	47	89	10,0	151,00
22 0530 0860 049	• 8,60	49	61	103	10,0	173,00
22 0530 0870 035	• 8,70	35	47	89	10,0	151,00
22 0530 0870 049	• 8,70	49	61	103	10,0	173,00
22 0530 0880 035	• 8,80	35	47	89	10,0	151,00
22 0530 0880 049	• 8,80	49	61	103	10,0	173,00
22 0530 0890 035	• 8,90	35	47	89	10,0	151,00
22 0530 0890 049	• 8,90	49	61	103	10,0	173,00
22 0530 0900 035	• 9,00	35	47	89	10,0	151,00
22 0530 0900 049	• 9,00	49	61	103	10,0	173,00
22 0530 0910 035	• 9,10	35	47	89	10,0	151,00
22 0530 0910 049	• 9,10	49	61	103	10,0	173,00
22 0530 0920 035	• 9,20	35	47	89	10,0	151,00
22 0530 0920 049	• 9,20	49	61	103	10,0	173,00
22 0530 0930 035	• 9,30	35	47	89	10,0	151,00
22 0530 0930 049	• 9,30	49	61	103	10,0	173,00
22 0530 0950 035	• 9,50	35	47	89	10,0	151,00
22 0530 0950 049	• 9,50	49	61	103	10,0	173,00
22 0530 0960 035	• 9,60	35	47	89	10,0	151,00
22 0530 0960 049	• 9,60	49	61	103	10,0	173,00
22 0530 0970 035	• 9,70	35	47	89	10,0	151,00
22 0530 0970 049	• 9,70	49	61	103	10,0	173,00
22 0530 0980 035	• 9,80	35	47	89	10,0	151,00
22 0530 0980 049	• 9,80	49	61	103	10,0	173,00
22 0530 1000 035	• 10,00	35	47	89	10,0	151,00
22 0530 1000 049	• 10,00	49	61	103	10,0	173,00
22 0530 1010 040	• 10,10	40	53	100	12,0	192,00
22 0530 1010 056	• 10,10	56	69	116	12,0	243,00
22 0530 1020 040	• 10,20	40	53	100	12,0	192,00
22 0530 1020 056	• 10,20	56	69	116	12,0	243,00
22 0530 1030 040	• 10,30	40	53	100	12,0	192,00
22 0530 1030 056	• 10,30	56	69	116	12,0	243,00
22 0530 1050 040	• 10,50	40	53	100	12,0	192,00
22 0530 1050 056	• 10,50	56	69	116	12,0	243,00
22 0530 1060 040	• 10,60	40	53	100	12,0	192,00
22 0530 1060 056	• 10,60	56	69	116	12,0	243,00
22 0530 1070 040	• 10,70	40	53	100	12,0	192,00
22 0530 1070 056	• 10,70	56	69	116	12,0	243,00
22 0530 1080 040	• 10,80	40	53	100	12,0	192,00
22 0530 1080 056	• 10,80	56	69	116	12,0	243,00
22 0530 1090 040	• 10,90	40	53	100	12,0	192,00
22 0530 1090 056	• 10,90	56	69	116	12,0	243,00
22 0530 1100 040	• 11,00	40	53	100	12,0	192,00
22 0530 1100 056	• 11,00	56	69	116	12,0	243,00
22 0530 1120 040	• 11,20	40	53	100	12,0	192,00
22 0530 1120 056	• 11,20	56	69	116	12,0	243,00
22 0530 1150 040	• 11,50	40	53	100	12,0	192,00
22 0530 1150 056	• 11,50	56	69	116	12,0	243,00
22 0530 1180 040	• 11,80	40	53	100	12,0	192,00
22 0530 1180 056	• 11,80	56	69	116	12,0	243,00
22 0530 1200 040	• 12,00	40	53	100	12,0	192,00
22 0530 1200 056	• 12,00	56	69	116	12,0	243,00



**22 0530**

180° Spitzenwinkel  
180° Point angle

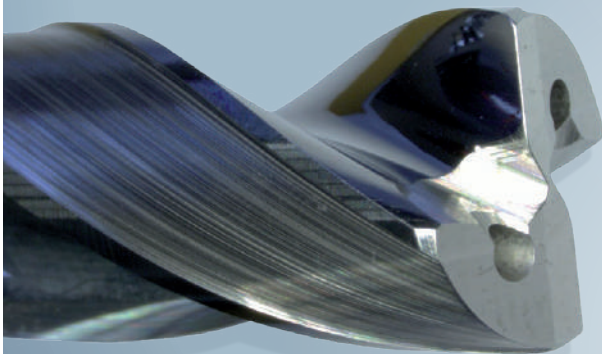



22 0389

Vollhartmetall-Pilot-Stufenbohrer 142°/90° abgestimmt auf Tieflochbohrer 22 0390  
Solid carbide pilot step drill 142°/90°. Designed for deep hole drill 22 0390

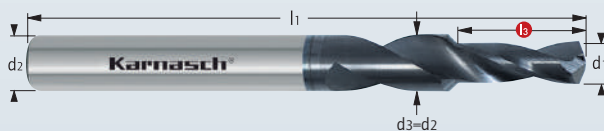

UNI

STAHL  
stahl  
< 1400 N/mm<sup>2</sup>

HRC  
< 52

GJL

GJS

GTW  
GTS

kurz-  
spanend  
short chip

⌀	Bohrungstoleranz Hole tolerance	⌀	Bohrungstoleranz Hole tolerance
m7		h7	
> 3-6	+0,004	> 3-6	+0,000
	+0,016		-0,012
> 6-10	+0,006	> 6-10	+0,000
	+0,021		-0,015
> 10-18	+0,007	> 10-18	+0,000
	+0,025		-0,018

Art.	d1 h7	l3 = 3xD	l2	l1	d2 h6	€
22 0389 0350 105	3,5	10,5	24	62	6	39,00
22 0389 0450 135	4,5	13,5	28	66	6	39,00
22 0389 0600 180	6,0	18,0	35	79	8	54,00
22 0389 0650 195	6,5	19,5	38	79	8	55,20
22 0389 0700 210	7,0	21,0	46	89	10	67,20
22 0389 0800 240	8,0	24,0	48	89	10	67,20
22 0389 0850 255	8,5	25,5	48	89	10	67,80
22 0389 0900 270	9,0	27,0	55	102	12	84,00
22 0389 1000 300	10,0	30,0	57	102	12	84,00
22 0389 1100 330	11,0	33,0	60	107	14	100,80
22 0389 1200 360	12,0	36,0	62	107	14	100,80

⊗ Sonderpreis / Sale Artikel. Lieferbar solange Vorrat.

Special price / sale article. While stocks last.

Alternativwerkzeug: 22 0471 + 22 0473 auf Seite / on page 272

Alternative Tool: 22 0402 + 22 0405 auf Seite / on page 254-255 + 259-261

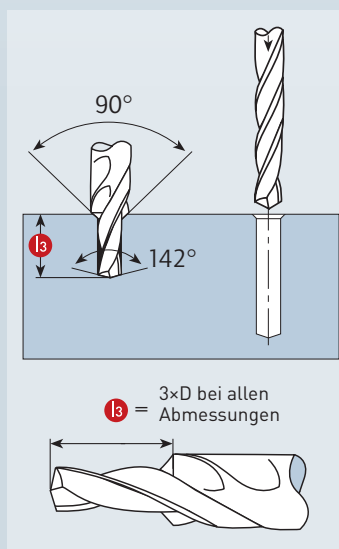

Schnittdaten  
Cutting data



## Richtwerte für den Einsatz der KARNASCH VHM-Hochleistungsbohrer ohne Innenkühlung Recommended cutting data for solid carbide twist drill, without interior cooling supply

Werkstoff- gruppe	Werkstoff	Festigkeit N/mm <sup>2</sup>	Schnittgeschwindig- keit Vc [m/min] ±10%	f = mm/U		
				Ø 3 - 5,5	Ø 6 - 8,5	Ø 9 - 12
1.1	St 42-8	< 450	100	0,18	0,25	0,30
1.2	C 50	< 650	90	0,18	0,25	0,30
2.1	51 Cr V4	< 600	70	0,15	0,20	0,28
2.2	26 Cr Mo 4	< 950	70	0,15	0,20	0,28
2.3	100 WV 4	< 1100	60	0,15	0,20	0,28
2.5	34 Cr Al 6	< 1000	60	0,15	0,20	0,28
2.6	31 Cr mo V9	< 1200	70	0,15	0,20	0,28
3.1	X 42 Cr 13	< 700	70	0,15	0,20	0,27
3.2	S 29 28	< 1400	40	0,08	0,12	0,15
7.1	GG 15	< 180 HB	100	0,24	0,32	0,42
7.2	GG 30	< 350 HB	100	0,24	0,32	0,42
7.4	GGG 60	< 200 HB	90	0,20	0,25	0,35
7.6	GTW 3504	< 230 HB	90	0,20	0,25	0,35
8.1	Toolox 44	44 HRC	30	0,08	0,09	0,10
12.0	Hardox 400	< 1350	25	0,08	0,12	0,15
12.1	Hardox 500	< 1800	20	0,08	0,12	0,15

# Besuchen Sie unsere internationalen Messen Visit our international exhibitions

Hannover · Stuttgart · Moskau · Chicago · Tokyo



IHR PARTNER FÜR: Metallindustrie    Automobilindustrie    Flugzeugindustrie    Schiffbau    Schienenbau    Formenbau    Forschung und Entwicklung

Besuchen Sie uns auf unserem Messestand und überzeugen Sie sich direkt vor Ort von unseren zukunftsweisenden Produkten und Innovationen. Lassen Sie sich in angenehmer Atmosphäre von unserem Fachpersonal kompetent beraten. Unsere internationalen Messetermine finden Sie auf unserer Webseite unter [www.karnasch.tools](http://www.karnasch.tools).



DIE AKTUELLEN MESSETERMINE  
CURRENT TRADE FAIR DATES

<http://www.karnasch.tools/de/messen/>

**Karnasch®**  
PROFESSIONAL TOOLS

- 1
- 2
- 3
- 4
- 5
- 6
- 7
- 8
- 9

Index

## 22 0390

Vollhartmetall-4-Fasen-Hochleistungsbohrer < 40xD  
Solid carbide 4-chamfer twist drill < 40xD

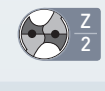
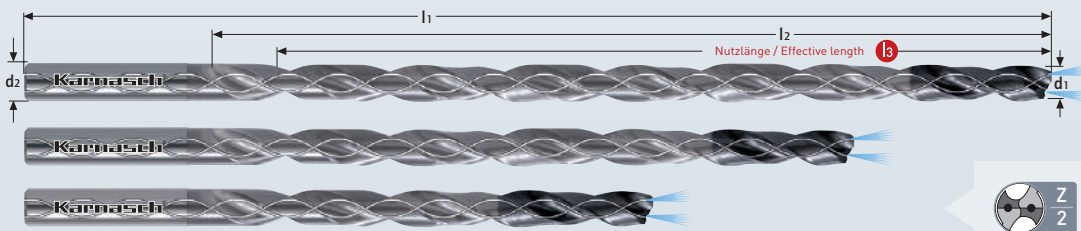

<b>MICRO GRAIN</b>	KARNASCH NORM
<b>SPEZIAL SPECIAL</b>	DIN 6535 Form HAK
	<b>HSC HPC</b>
	<b>DVC-X2 hp<sup>2</sup>-finish</b>
	<b>50-80 bar</b>

h7	Bohrertoleranz Drill tolerance
> 3,0 -	+0,000
6,0	-0,012
> 6,0 -	+0,000
10,0	-0,015
>10,0 -	+0,000
14,0	-0,018

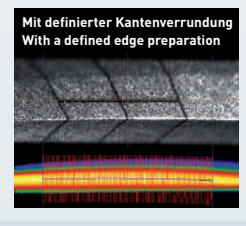

- 1
- 2
- 3
- 4
- 5
- 6
- 7
- 8
- 9

kurz-spanend  
short chip

Art.	d1 h7	l3	l2	l1	d2 h6	€
22 0390 0300 030	% 3,0	30	40	80	6	133,20
22 0390 0300 040	% 3,0	40	50	90	6	135,60
22 0390 0300 060	% 3,0	60	65	105	6	136,20
22 0390 0310 045	% 3,1	45	50	90	6	140,40
22 0390 0310 056	% 3,1	56	60	100	6	140,40
22 0390 0320 045	% 3,2	45	50	90	6	140,40
22 0390 0330 056	% 3,3	56	60	100	6	140,40
22 0390 0340 045	% 3,4	45	50	90	6	140,40
22 0390 0340 056	% 3,4	56	60	100	6	140,40
22 0390 0350 050	% 3,5	50	60	100	6	137,40
22 0390 0350 060	% 3,5	60	65	105	6	137,40
22 0390 0350 070	% 3,5	70	75	115	6	141,60
22 0390 0350 144	% 3,5	144	150	190	6	226,20
22 0390 0360 050	% 3,6	50	55	100	6	140,40
22 0390 0360 053	% 3,6	53	68	110	6	150,00
22 0390 0370 050	% 3,7	50	55	100	6	140,40
22 0390 0370 053	% 3,7	53	68	110	6	150,00
22 0390 0380 050	% 3,8	50	55	100	6	140,40
22 0390 0380 053	% 3,8	53	68	110	6	150,00
22 0390 0390 053	% 3,9	53	68	110	6	150,00
22 0390 0400 055	% 4,0	55	65	105	6	146,40
22 0390 0400 075	% 4,0	75	80	120	6	148,80
22 0390 0400 085	% 4,0	85	90	130	6	162,00
22 0390 0400 095	% 4,0	95	100	140	6	163,20
22 0390 0400 105	% 4,0	105	110	150	6	183,00
22 0390 0400 120	% 4,0	120	125	165	6	196,20
22 0390 0400 160	% 4,0	160	165	210	6	253,80
22 0390 0410 060	% 4,1	60	65	105	6	146,40
22 0390 0410 073	% 4,1	73	78	118	6	148,80
22 0390 0420 060	% 4,2	60	65	105	6	146,40
22 0390 0420 154	% 4,2	154	160	205	6	253,80
22 0390 0420 174	% 4,2	174	180	225	6	256,80
22 0390 0430 060	% 4,3	60	65	105	6	146,40
22 0390 0430 073	% 4,3	73	78	118	6	148,80
22 0390 0440 060	% 4,4	60	65	105	6	146,40
22 0390 0440 073	% 4,4	73	78	118	6	148,80
22 0390 0450 060	% 4,5	60	65	105	6	146,40
22 0390 0450 080	% 4,5	80	88	130	6	149,40
22 0390 0450 110	% 4,5	110	118	160	6	171,00
22 0390 0450 184	% 4,5	184	190	230	6	256,80
22 0390 0460 065	% 4,6	65	71	110	6	146,40
22 0390 0460 079	% 4,6	79	85	125	6	162,00
22 0390 0470 065	% 4,7	65	71	110	6	146,40
22 0390 0470 079	% 4,7	79	85	125	6	162,00
22 0390 0480 065	% 4,8	65	71	110	6	146,40
22 0390 0480 079	% 4,8	79	85	125	6	162,00
22 0390 0490 065	% 4,9	65	71	110	6	146,40
22 0390 0490 079	% 4,9	79	85	125	6	162,00
22 0390 0500 070	% 5,0	70	80	120	6	142,80
22 0390 0500 090	% 5,0	90	98	140	6	150,60
22 0390 0500 109	% 5,0	109	115	155	6	171,00
22 0390 0500 120	% 5,0	120	128	170	6	172,80

% Sonderpreis / Sale Artikel. Lieferbar solange Vorrat.  
Special price / sale article. While stocks last.

Schnittdaten  
Cutting data

Film  
Movie

1245

Art.	d1 h7	l3	l2	l1	d2 h6	€
22 0390 0500 200	% 5,0	200	210	250	6	270,00
22 0390 0510 074	% 5,1	74	80	120	6	142,80
22 0390 0510 088	% 5,1	88	95	135	6	150,60
22 0390 0520 074	% 5,2	74	80	120	6	142,80
22 0390 0520 088	% 5,2	88	95	135	6	150,60
22 0390 0530 074	% 5,3	74	80	120	6	142,80
22 0390 0530 088	% 5,3	88	95	135	6	150,60
22 0390 0540 074	% 5,4	74	80	120	6	142,80
22 0390 0540 088	% 5,4	88	95	135	6	150,60
22 0390 0550 100	% 5,5	100	108	150	6	151,80
22 0390 0550 130	% 5,5	130	138	180	6	172,80
22 0390 0550 160	% 5,5	160	168	210	6	192,60
22 0390 0560 079	% 5,6	79	85	125	6	149,40
22 0390 0560 097	% 5,6	97	105	145	6	183,00
22 0390 0570 079	% 5,7	79	85	125	6	149,40
22 0390 0570 097	% 5,7	97	105	145	6	183,00
22 0390 0580 079	% 5,8	79	85	125	6	149,40
22 0390 0580 097	% 5,8	97	105	145	6	183,00
22 0390 0590 079	% 5,9	79	85	125	6	149,40
22 0390 0590 097	% 5,9	97	105	145	6	183,00
22 0390 0600 070	% 6,0	70	85	125	6	149,40
22 0390 0600 090	% 6,0	90	105	145	6	166,80
22 0390 0600 145	% 6,0	145	153	195	6	170,40
22 0390 0600 180	% 6,0	180	188	230	6	213,60
22 0390 0600 248	% 6,0	248	255	295	6	234,00
22 0390 0610 082	% 6,1	82	90	130	8	193,80
22 0390 0620 082	% 6,2	82	90	130	8	193,80
22 0390 0620 102	% 6,2	102	110	150	8	210,00
22 0390 0630 082	% 6,3	82	90	130	8	193,80
22 0390 0630 102	% 6,3	102	110	150	8	210,00
22 0390 0640 082	% 6,4	82	90	130	8	193,80
22 0390 0640 102	% 6,4	102	110	150	8	210,00
22 0390 0650 095	% 6,5	95	110	150	8	210,00
22 0390 0650 115	% 6,5	115	130	170	8	218,40
22 0390 0650 155	% 6,5	155	170	210	8	255,60
22 0390 0650 195	% 6,5	195	210	250	8	295,20
22 0390 0650 262	% 6,5	262	270	310	8	384,00
22 0390 0660 092	% 6,6	92	100	140	8	196,80
22 0390 0660 112	% 6,6	112	120	160	8	205,20
22 0390 0670 092	% 6,7	92	100	140	8	196,80
22 0390 0670 112	% 6,7	112	120	160	8	205,20
22 0390 0680 092	% 6,8	92	100	140	8	196,80
22 0390 0680 112	% 6,8	112	120	160	8	205,20
22 0390 0690 092	% 6,9	92	100	140	8	196,80
22 0390 0690 112	% 6,9	112	120	160	8	205,20
22 0390 0700 095	% 7,0	95	110	150	8	211,80
22 0390 0700 125	% 7,0	125	140	180	8	220,80
22 0390 0700 165	% 7,0	165	180	220	8	255,60
22 0390 0700 210	% 7,0	210	225	265	8	298,80
22 0390 0710 095	% 7,1	95	105	150	8	211,80
22 0390 0710 120	% 7,1	120	130	170	8	218,40
22 0390 0720 100	% 7,2	100	110	150	8	211,80
22 0390 0730 100	% 7,3	100	110	150	8	211,80
22 0390 0740 100	% 7,4	100	110	150	8	211,80
22 0390 0750 100	% 7,5	100	110	150	8	211,80
22 0390 0750 120	% 7,5	120	130	170	8	218,40
22 0390 0760 105	% 7,6	105	115	155	8	214,80
22 0390 0760 125	% 7,6	125	135	175	8	220,80
22 0390 0770 105	% 7,7	105	115	155	8	214,80
22 0390 0770 125	% 7,7	125	135	175	8	220,80
22 0390 0780 105	% 7,8	105	115	155	8	214,80
22 0390 0780 125	% 7,8	125	135	175	8	220,80
22 0390 0790 105	% 7,9	105	115	155	8	214,80
22 0390 0800 095	% 8,0	95	115	155	8	211,80
22 0390 0800 145	% 8,0	145	160	200	8	219,00
22 0390 0800 190	% 8,0	190	205	245	8	254,40
22 0390 0800 240	% 8,0	240	260	300	8	312,00
22 0390 0810 108	% 8,1	108	118	160	10	261,60
22 0390 0810 135	% 8,1	135	145	190	10	310,20
22 0390 0820 108	% 8,2	108	118	160	10	261,60
22 0390 0820 135	% 8,2	135	145	190	10	310,20
22 0390 0830 108	% 8,3	108	118	160	10	261,60
22 0390 0840 108	% 8,4	108	118	160	10	261,60
22 0390 0840 135	% 8,4	135	145	190	10	310,20
22 0390 0850 150	% 8,5	150	160	205	10	295,80
22 0390 0850 200	% 8,5	200	210	255	10	355,80
22 0390 0860 118	% 8,6	118	130	175	10	277,20
22 0390 0860 144	% 8,6	144	155	200	10	295,80
22 0390 0870 118	% 8,7	118	130	175	10	291,00
22 0390 0870 144	% 8,7	144	155	200	10	295,80
22 0390 0880 118	% 8,8	118	130	175	10	277,20

Art.	d1 h7	l3	l2	l1	d2 h6	€
22 0390 0880 144	% 8,8	144	155	200	10	295,80
22 0390 0890 118	% 8,9	118	130	175	10	277,20
22 0390 0900 110	% 9,0	110	130	175	10	277,20
22 0390 0900 118	% 9,0	118	130	175	10	277,20
22 0390 0900 150	% 9,0	150	160	205	10	285,60
22 0390 0900 200	% 9,0	200	210	255	10	344,40
22 0390 0900 250	% 9,0	250	260	305	10	410,40
22 0390 0910 123	% 9,1	123	135	180	10	281,40
22 0390 0910 155	% 9,1	155	170	210	10	320,40
22 0390 0920 123	% 9,2	123	135	180	10	281,40
22 0390 0920 155	% 9,2	155	170	210	10	320,40
22 0390 0930 123	% 9,3	123	135	180	10	281,40
22 0390 0940 123	% 9,4	123	135	180	10	281,40
22 0390 0950 123	% 9,5	123	135	180	10	281,40
22 0390 0950 155	% 9,5	155	170	210	10	320,40
22 0390 0960 130	% 9,6	130	145	190	10	286,80
22 0390 0960 163	% 9,6	163	175	220	10	323,40
22 0390 0970 130	% 9,7	130	145	190	10	286,80
22 0390 0970 163	% 9,7	163	175	220	10	323,40
22 0390 0980 130	% 9,8	130	145	190	10	286,80
22 0390 0980 163	% 9,8	163	175	220	10	323,40
22 0390 0990 130	% 9,9	130	145	190	10	286,80
22 0390 0990 163	% 9,9	163	175	220	10	323,40
22 0390 1000 110	% 10,0	110	130	175	10	270,00
22 0390 1000 150	% 10,0	150	160	205	10	271,80
22 0390 1000 180	% 10,0	180	190	235	10	297,00
22 0390 1000 220	% 10,0	220	230	275	10	339,00
22 0390 1010 142	% 10,1	142	155	205	12	378,60
22 0390 1010 167	% 10,1	167	180	230	12	441,00
22 0390 1020 142	% 10,2	142	155	205	12	378,60
22 0390 1020 167	% 10,2	167	180	230	12	441,00
22 0390 1030 142	% 10,3	142	155	205	12	378,60
22 0390 1040 142	% 10,4	142	155	205	12	378,60
22 0390 1050 142	% 10,5	142	155	205	12	378,60
22 0390 1050 167	% 10,5	167	180	230	12	441,00
22 0390 1070 147	% 10,7	147	160	210	12	378,60
22 0390 1080 147	% 10,8	147	160	210	12	378,60
22 0390 1100 180	% 11,0	180	194	245	12	382,80
22 0390 1100 220	% 11,0	220	234	285	12	433,80
22 0390 1150 186	% 11,5	186	200	250	12	454,80
22 0390 1180 186	% 11,8	186	200	250	12	454,80
22 0390 1200 180	% 12,0	180	194	245	12	357,60
22 0390 1200 220	% 12,0	220	234	285	12	404,40

Einsatzempfehlung: Wir empfehlen über 12xD Bohrtiefe eine Pilotbohrung mit 22 0402 oder 22 0405 in der jeweils kürzesten Ausführung. Bei schrägen Flächen empfehlen wir unseren VHM-Bohrer 22 0404.

% Sonderpreis / Sale Artikel. Lieferbar solange Vorrat.

Application recommendation: We recommend over 12xD drilling depth a pilot drilling with 22 0402 or 22 0405 in each case the short version. We recommend our solid carbide drill 22 0404 on bevel surfaces.

% Special price / sale article. While stocks last.



22 0392

Vollhartmetall-Hochleistungsbohrer < 40xD  
Solid carbide twist drill < 40xD

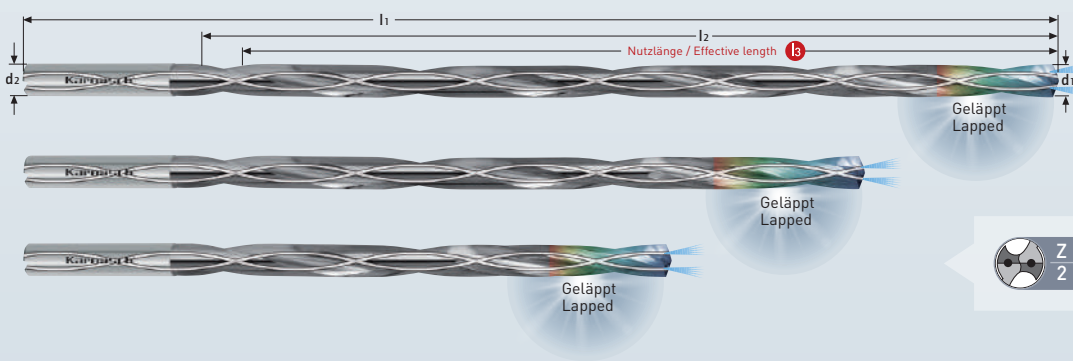

<b>MICRO GRAIN</b>	KARNASCH NORM
<b>W/M</b>	DIN 6535 Form HA
	<b>HSC HPC</b>
	<b>NHC 7000</b>
	50-80 bar

h7	Bohrungstoleranz Hole tolerance
> 3-6	+0,000 -0,012
> 6-10	+0,000 -0,015
> 10-18	+0,000 -0,018

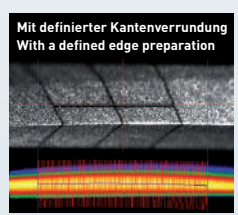

Schnittdaten Cutting data	Film Movie	Zeichnungen Drawings
1242		DXF/STEP

Art.	d1 h7	l3	l2	l1	d2 h6	€
22 0392 0100 006	• 1,0	6	8	55	4	83,00
22 0392 0110 010	• 1,1	10	12	55	4	83,00
22 0392 0120 010	• 1,2	10	12	55	4	83,00
22 0392 0130 010	• 1,3	10	12	55	4	83,00
22 0392 0140 010	• 1,4	10	12	55	4	83,00
22 0392 0150 010	• 1,5	10	12	55	4	83,00
22 0392 0160 013	• 1,6	13	16	55	4	83,00
22 0392 0170 013	• 1,7	13	16	55	4	83,00
22 0392 0180 013	• 1,8	13	16	55	4	83,00
22 0392 0190 013	• 1,9	13	16	55	4	83,00
22 0392 0200 017	• 2,0	17	21	57	4	83,00
22 0392 0200 047	• 2,0	47	50	92	4	130,00
22 0392 0200 067	• 2,0	67	70	115	4	146,00
22 0392 0210 017	• 2,1	17	21	57	4	83,00
22 0392 0220 017	• 2,2	17	21	57	4	83,00
22 0392 0220 044	• 2,2	44	48	80	4	75,00
22 0392 0220 047	• 2,2	47	50	92	4	130,00
22 0392 0220 066	• 2,2	66	70	110	4	146,00
22 0392 0230 017	• 2,3	17	21	57	4	83,00
22 0392 0230 046	• 2,3	46	50	80	4	75,00
22 0392 0230 047	• 2,3	47	50	92	4	130,00
22 0392 0230 067	• 2,3	67	70	115	4	146,00
22 0392 0230 069	• 2,3	69	73	110	4	84,60
22 0392 0240 017	• 2,4	17	21	57	4	83,00
22 0392 0240 048	• 2,4	48	52	85	4	88,20
22 0392 0240 066	• 2,4	66	70	112	4	153,00
22 0392 0240 072	• 2,4	72	76	110	4	98,40
22 0392 0240 086	• 2,4	86	90	138	4	170,00
22 0392 0250 017	• 2,5	17	21	57	4	83,00
22 0392 0250 066	• 2,5	66	70	112	4	144,00
22 0392 0250 075	• 2,5	75	80	110	4	98,40
22 0392 0250 086	• 2,5	86	90	138	4	170,00
22 0392 0260 017	• 2,6	17	21	57	4	83,00
22 0392 0270 017	• 2,7	17	21	57	4	83,00
22 0392 0270 054	• 2,7	54	59	90	4	83,40
22 0392 0270 066	• 2,7	66	70	112	4	144,00
22 0392 0270 081	• 2,7	81	86	120	4	98,40
22 0392 0270 086	• 2,7	86	90	138	4	170,00
22 0392 0280 017	• 2,8	17	21	57	4	83,00
22 0392 0280 056	• 2,8	56	61	95	4	83,40
22 0392 0280 066	• 2,8	66	70	112	4	144,00
22 0392 0280 084	• 2,8	84	89	120	4	98,40
22 0392 0280 086	• 2,8	86	90	138	4	170,00
22 0392 0290 017	• 2,9	17	21	57	4	83,00
22 0392 0300 022	• 3,0	22	28	66	6	83,00
22 0392 0300 029	• 3,0	29	34	72	6	136,00
22 0392 0300 045	• 3,0	45	51	95	6	163,00
22 0392 0300 055	• 3,0	55	60	100	6	173,00
22 0392 0300 075	• 3,0	75	80	120	6	191,00
22 0392 0300 090	• 3,0	90	96	140	6	221,00
22 0392 0300 100	• 3,0	100	105	150	6	281,00
22 0392 0310 022	• 3,1	22	28	66	6	83,00

• Sonderpreis / Sale Artikel. Lieferbar solange Vorrat.  
Special price / sale article. While stocks last.

Art.	d1 h7	l3	l2	l1	d2 h6	€
22 0392 0310 029	• 3,1	29	34	72	6	136,00
22 0392 0310 048	• 3,1	48	54	92	6	163,00
22 0392 0320 023	• 3,2	23	28	66	6	83,00
22 0392 0320 029	• 3,2	29	34	72	6	136,00
22 0392 0320 048	• 3,2	48	54	95	6	163,00
22 0392 0320 055	• 3,2	55	60	100	6	173,00
22 0392 0320 064	• 3,2	64	70	110	6	106,20
22 0392 0320 075	• 3,2	75	80	120	6	191,00
22 0392 0320 080	• 3,2	80	86	125	6	111,00
22 0392 0320 093	• 3,2	93	98	135	6	221,00
22 0392 0320 096	• 3,2	96	102	140	6	128,40
22 0392 0320 100	• 3,2	100	105	150	6	281,00
22 0392 0330 023	• 3,3	23	28	66	6	83,00
22 0392 0330 029	• 3,3	29	34	72	6	136,00
22 0392 0330 048	• 3,3	48	54	92	6	163,00
22 0392 0330 050	• 3,3	50	56	95	6	173,00
22 0392 0330 066	• 3,3	66	72	110	6	111,00
22 0392 0330 075	• 3,3	75	80	120	6	191,00
22 0392 0330 083	• 3,3	83	89	130	6	115,20
22 0392 0330 099	• 3,3	99	105	150	6	128,40
22 0392 0330 105	• 3,3	105	110	150	6	221,00
22 0392 0330 129	• 3,3	129	135	185	6	281,00
22 0392 0340 023	• 3,4	23	28	66	6	83,00
22 0392 0340 029	• 3,4	29	34	72	6	136,00
22 0392 0340 048	• 3,4	48	54	92	6	163,00
22 0392 0350 023	• 3,5	23	28	66	6	83,00
22 0392 0350 029	• 3,5	29	34	72	6	136,00
22 0392 0350 048	• 3,5	48	54	92	6	163,00
22 0392 0350 053	• 3,5	53	59	100	6	173,00
22 0392 0350 070	• 3,5	70	77	120	6	191,00
22 0392 0350 088	• 3,5	88	94	140	6	128,40
22 0392 0350 105	• 3,5	105	112	150	6	221,00
22 0392 0350 129	• 3,5	129	135	185	6	281,00
22 0392 0360 023	• 3,6	23	28	66	6	83,00
22 0392 0360 029	• 3,6	29	34	72	6	136,00
22 0392 0360 048	• 3,6	48	54	92	6	163,00
22 0392 0370 023	• 3,7	23	28	66	6	83,00
22 0392 0370 029	• 3,7	29	34	72	6	136,00
22 0392 0370 048	• 3,7	48	54	92	6	163,00
22 0392 0380 029	• 3,8	29	36	74	6	82,00
22 0392 0380 036	• 3,8	36	43	80	6	136,00
22 0392 0380 057	• 3,8	57	64	102	6	163,00
22 0392 0380 069	• 3,8	69	75	115	6	179,00
22 0392 0380 076	• 3,8	76	83	130	6	115,20
22 0392 0380 084	• 3,8	84	90	130	6	198,00
22 0392 0380 095	• 3,8	95	102	150	6	145,80
22 0392 0380 114	• 3,8	114	120	160	6	251,00
22 0392 0380 129	• 3,8	129	135	185	6	281,00
22 0392 0390 029	• 3,9	29	36	74	6	82,00
22 0392 0390 036	• 3,9	36	43	80	6	136,00
22 0392 0390 057	• 3,9	57	64	102	6	163,00
22 0392 0400 029	• 4,0	29	36	74	6	82,00
22 0392 0400 036	• 4,0	36	43	80	6	136,00
22 0392 0400 057	• 4,0	57	64	102	6	163,00
22 0392 0400 060	• 4,0	60	68	110	6	99,60
22 0392 0400 069	• 4,0	69	75	115	6	179,00
22 0392 0400 080	• 4,0	80	88	130	6	198,00
22 0392 0400 114	• 4,0	114	120	160	6	251,00
22 0392 0400 120	• 4,0	120	128	170	6	156,00
22 0392 0400 129	• 4,0	129	135	185	6	281,00
22 0392 0400 160	• 4,0	160	168	210	6	180,00
22 0392 0410 029	• 4,1	29	36	74	6	82,00
22 0392 0410 036	• 4,1	36	43	80	6	136,00
22 0392 0410 057	• 4,1	57	64	102	6	163,00
22 0392 0420 029	• 4,2	29	36	74	6	82,00
22 0392 0420 036	• 4,2	36	43	80	6	136,00
22 0392 0420 057	• 4,2	57	64	102	6	163,00
22 0392 0420 063	• 4,2	63	71	120	6	111,60
22 0392 0420 069	• 4,2	69	75	115	6	192,00
22 0392 0420 084	• 4,2	84	92	140	6	118,20
22 0392 0420 103	• 4,2	103	110	160	6	213,00
22 0392 0420 114	• 4,2	114	120	160	6	251,00
22 0392 0420 126	• 4,2	126	134	185	6	281,00
22 0392 0430 029	• 4,3	29	36	74	6	82,00
22 0392 0430 036	• 4,3	36	43	80	6	136,00
22 0392 0430 057	• 4,3	57	64	102	6	163,00
22 0392 0440 029	• 4,4	29	36	74	6	82,00
22 0392 0440 036	• 4,4	36	43	80	6	136,00
22 0392 0440 057	• 4,4	57	64	102	6	163,00
22 0392 0450 029	• 4,5	29	36	74	6	82,00
22 0392 0450 036	• 4,5	36	43	80	6	136,00
22 0392 0450 057	• 4,5	57	64	102	6	163,00
22 0392 0450 068	• 4,5	68	76	120	6	106,20
22 0392 0450 082	• 4,5	82	90	130	6	192,00
22 0392 0450 090	• 4,5	90	99	140	6	118,20
22 0392 0450 103	• 4,5	103	110	160	6	213,00
22 0392 0450 112	• 4,5	112	121	165	6	143,40

Art.	d1 h7	l3	l2	l1	d2 h6	€
22 0392 0450 127	• 4,5	127	135	180	6	261,00
22 0392 0450 135	• 4,5	135	144	185	6	168,00
22 0392 0450 157	• 4,5	157	165	215	6	299,00
22 0392 0460 029	• 4,6	29	36	74	6	82,00
22 0392 0460 036	• 4,6	36	43	80	6	136,00
22 0392 0460 057	• 4,6	57	64	102	6	163,00
22 0392 0470 029	• 4,7	29	36	74	6	82,00
22 0392 0470 036	• 4,7	36	43	80	6	136,00
22 0392 0470 057	• 4,7	57	64	102	6	163,00
22 0392 0480 035	• 4,8	35	44	82	6	82,00
22 0392 0480 048	• 4,8	48	57	95	6	136,00
22 0392 0480 069	• 4,8	69	78	116	6	163,00
22 0392 0480 072	• 4,8	72	81	125	6	112,20
22 0392 0480 082	• 4,8	82	90	130	6	203,00
22 0392 0480 096	• 4,8	96	105	150	6	124,80
22 0392 0480 112	• 4,8	112	120	160	6	225,00
22 0392 0480 120	• 4,8	120	129	175	6	146,40
22 0392 0480 127	• 4,8	127	135	180	6	261,00
22 0392 0480 144	• 4,8	144	153	200	6	168,00
22 0392 0480 157	• 4,8	157	165	215	6	299,00
22 0392 0490 035	• 4,9	35	44	82	6	82,00
22 0392 0490 048	• 4,9	48	57	95	6	136,00
22 0392 0490 069	• 4,9	69	78	116	6	163,00
22 0392 0500 035	• 5,0	35	44	82	6	82,00
22 0392 0500 048	• 5,0	48	57	95	6	136,00
22 0392 0500 069	• 5,0	69	78	116	6	163,00
22 0392 0500 082	• 5,0	82	90	130	6	203,00
22 0392 0500 100	• 5,0	100	110	150	6	124,80
22 0392 0500 112	• 5,0	112	120	160	6	225,00
22 0392 0500 125	• 5,0	125	135	175	6	261,00
22 0392 0500 150	• 5,0	150	160	200	6	168,00
22 0392 0500 157	• 5,0	157	165	215	6	299,00
22 0392 0500 200	• 5,0	200	210	250	6	233,40
22 0392 0510 035	• 5,1	35	44	82	6	82,00
22 0392 0510 048	• 5,1	48	57	95	6	136,00
22 0392 0510 069	• 5,1	69	78	116	6	163,00
22 0392 0520 035	• 5,2	35	44	82	6	82,00
22 0392 0520 048	• 5,2	48	57	95	6	136,00
22 0392 0520 069	• 5,2	69	78	116	6	163,00
22 0392 0530 035	• 5,3	35	44	82	6	82,00
22 0392 0530 048	• 5,3	48	57	95	6	136,00
22 0392 0530 069	• 5,3	69	78	116	6	163,00
22 0392 0540 035	• 5,4	35	44	82	6	82,00
22 0392 0540 048	• 5,4	48	57	95	6	136,00
22 0392 0540 069	• 5,4	69	78	116	6	163,00
22 0392 0550 035	• 5,5	35	44	82	6	82,00
22 0392 0550 048	• 5,5	48	57	95	6	136,00
22 0392 0550 069	• 5,5	69	78	116	6	163,00
22 0392 0550 083	• 5,5	83	93	135	6	118,20
22 0392 0550 099	• 5,5	99	108	150	6	212,00
22 0392 0550 110	• 5,5	110	121	160	6	130,80
22 0392 0550 131	• 5,5	131	140	185	6	235,00
22 0392 0550 138	• 5,5	138	148	190	6	156,00
22 0392 0550 159	• 5,5	159	168	205	6	281,00
22 0392 0550 165	• 5,5	165	176	215	6	174,60
22 0392 0550 171	• 5,5	171	180	230	6	312,00
22 0392 0560 035	• 5,6	35	44	82	6	82,00
22 0392 0560 048	• 5,6	48	57	95	6	136,00
22 0392 0560 069	• 5,6	69	78	116	6	163,00
22 0392 0570 035	• 5,7	35	44	82	6	82,00
22 0392 0570 048	• 5,7	48	57	95	6	136,00
22 0392 0570 069	• 5,7	69	78	116	6	163,00
22 0392 0580 035	• 5,8	35	44	82	6	82,00
22 0392 0580 048	• 5,8	48	57	95	6	136,00
22 0392 0580 069	• 5,8	69	78	116	6	163,00
22 0392 0580 087	• 5,8	87	98	140	6	118,20
22 0392 0580 099	• 5,8	99	108	150	6	212,00
22 0392 0580 116	• 5,8	116	127	170	6	130,80
22 0392 0580 131	• 5,8	131	140	185	6	235,00
22 0392 0580 145	• 5,8	145	156	200	6	156,00
22 0392 0580 159	• 5,8	159	168	205	6	281,00
22 0392 0580 171	• 5,8	171	180	230	6	312,00
22 0392 0590 035	• 5,9	35	44	82	6	82,00
22 0392 0590 048	• 5,9	48	57	95		

## 22 0392

Vollhartmetall-Hochleistungsbohrer < 40xD  
Solid carbide twist drill < 40xD

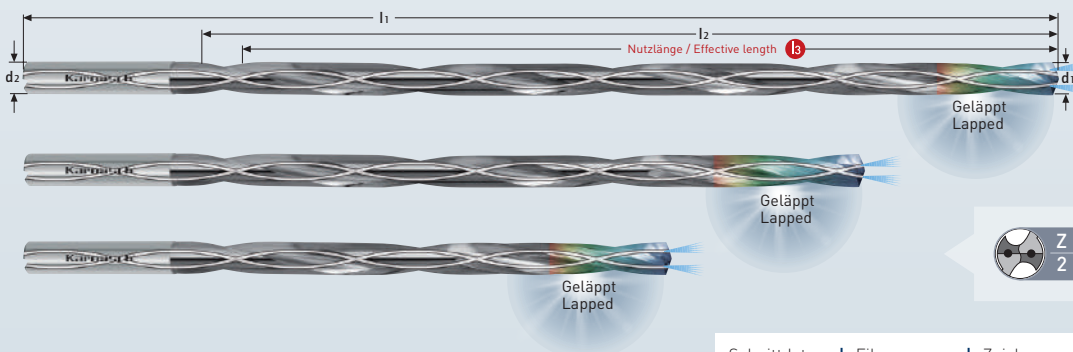

<b>MICRO GRAIN</b>	<b>KARNASCH NORM</b>
<b>W/M</b>	<b>DIN 6535 Form HA</b>
	<b>HSC HPC</b>
	<b>NHC 7000</b>
	<b>50-80 bar</b>

h7	Bohrungstoleranz Hole tolerance
> 3-6	+0,000
> 6-10	-0,012
> 10-18	+0,000
	-0,015
	+0,000
	-0,018

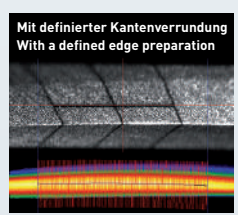

Schnittdaten Cutting data	Film Movie	Zeichnungen Drawings
1242		DXF/STEP

Art.	d1 h7	l3	l2	l1	d2 h6	€
22 0392 0610 066	• 6,1	66	76	114	8	170,00
22 0392 0610 096	• 6,1	96	108	146	8	223,00
22 0392 0620 043	• 6,2	43	53	90	8	90,00
22 0392 0620 066	• 6,2	66	76	114	8	170,00
22 0392 0620 096	• 6,2	96	108	146	8	223,00
22 0392 0630 043	• 6,3	43	53	90	8	90,00
22 0392 0630 066	• 6,3	66	76	114	8	170,00
22 0392 0630 096	• 6,3	96	108	146	8	223,00
22 0392 0640 043	• 6,4	43	53	90	8	90,00
22 0392 0640 066	• 6,4	66	76	114	8	170,00
22 0392 0640 096	• 6,4	96	108	146	8	223,00
22 0392 0650 043	• 6,5	43	53	90	8	90,00
22 0392 0650 066	• 6,5	66	76	114	8	170,00
22 0392 0650 096	• 6,5	96	108	146	8	223,00
22 0392 0650 114	• 6,5	114	125	165	8	226,00
22 0392 0650 130	• 6,5	130	143	185	8	137,40
22 0392 0650 149	• 6,5	149	160	210	8	252,00
22 0392 0650 163	• 6,5	163	175	215	8	174,60
22 0392 0650 189	• 6,5	189	200	240	8	326,00
22 0392 0650 195	• 6,5	195	208	250	8	193,20
22 0392 0650 205	• 6,5	205	215	280	8	343,00
22 0392 0660 043	• 6,6	43	53	90	8	90,00
22 0392 0660 066	• 6,6	66	76	114	8	170,00
22 0392 0660 096	• 6,6	96	108	146	8	223,00
22 0392 0670 043	• 6,7	43	53	90	8	90,00
22 0392 0670 066	• 6,7	66	76	114	8	170,00
22 0392 0670 096	• 6,7	96	108	146	8	223,00
22 0392 0680 043	• 6,8	43	53	90	8	90,00
22 0392 0680 066	• 6,8	66	76	114	8	170,00
22 0392 0680 096	• 6,8	96	108	146	8	223,00
22 0392 0680 102	• 6,8	102	115	160	8	131,40
22 0392 0680 114	• 6,8	114	125	165	8	226,00
22 0392 0680 136	• 6,8	136	149	195	8	149,40
22 0392 0680 149	• 6,8	149	160	210	8	270,00
22 0392 0680 170	• 6,8	170	183	230	8	174,60
22 0392 0680 189	• 6,8	189	200	240	8	313,00
22 0392 0680 204	• 6,8	204	217	265	8	199,20
22 0392 0680 219	• 6,8	219	230	280	8	357,00
22 0392 0690 043	• 6,9	43	53	90	8	90,00
22 0392 0690 066	• 6,9	66	76	114	8	170,00
22 0392 0690 096	• 6,9	96	108	146	8	223,00
22 0392 0700 041	• 7,0	41	53	90	8	90,00
22 0392 0700 064	• 7,0	64	76	114	8	170,00
22 0392 0700 096	• 7,0	96	108	146	8	223,00
22 0392 0700 105	• 7,0	105	119	160	8	131,40
22 0392 0700 114	• 7,0	114	125	165	8	226,00
22 0392 0700 140	• 7,0	140	154	195	8	156,00
22 0392 0700 149	• 7,0	149	160	210	8	270,00
22 0392 0700 175	• 7,0	175	189	230	8	174,60
22 0392 0700 189	• 7,0	189	200	240	8	313,00
22 0392 0700 219	• 7,0	219	230	280	8	357,00
22 0392 0710 041	• 7,1	41	53	90	8	90,00
22 0392 0710 064	• 7,1	64	76	114	8	170,00
22 0392 0710 096	• 7,1	96	108	146	8	223,00

Art.	d1 h7	l3	l2	l1	d2 h6	€
22 0392 0720 041	• 7,2	41	53	90	8	90,00
22 0392 0720 064	• 7,2	64	76	114	8	170,00
22 0392 0720 096	• 7,2	96	108	146	8	223,00
22 0392 0730 041	• 7,3	41	53	90	8	90,00
22 0392 0730 064	• 7,3	64	76	114	8	170,00
22 0392 0730 096	• 7,3	96	108	146	8	223,00
22 0392 0740 041	• 7,4	41	53	90	8	90,00
22 0392 0740 064	• 7,4	64	76	114	8	170,00
22 0392 0740 096	• 7,4	96	108	146	8	223,00
22 0392 0750 041	• 7,5	41	53	90	8	90,00
22 0392 0750 064	• 7,5	64	76	114	8	170,00
22 0392 0750 096	• 7,5	96	108	146	8	223,00
22 0392 0750 113	• 7,5	113	128	165	8	128,40
22 0392 0750 128	• 7,5	128	140	180	8	270,00
22 0392 0750 150	• 7,5	150	165	210	8	168,00
22 0392 0750 168	• 7,5	168	180	230	8	301,00
22 0392 0750 188	• 7,5	188	203	255	8	199,20
22 0392 0750 208	• 7,5	208	220	260	8	349,00
22 0392 0750 219	• 7,5	219	230	280	8	357,00
22 0392 0750 225	• 7,5	225	240	280	8	220,80
22 0392 0760 041	• 7,6	41	53	90	8	90,00
22 0392 0760 064	• 7,6	64	76	114	8	170,00
22 0392 0760 096	• 7,6	96	108	146	8	223,00
22 0392 0770 041	• 7,7	41	53	90	8	90,00
22 0392 0770 064	• 7,7	64	76	114	8	170,00
22 0392 0770 096	• 7,7	96	108	146	8	223,00
22 0392 0780 041	• 7,8	41	53	90	8	90,00
22 0392 0780 064	• 7,8	64	76	114	8	170,00
22 0392 0780 096	• 7,8	96	108	146	8	223,00
22 0392 0780 117	• 7,8	117	133	170	8	149,40
22 0392 0780 128	• 7,8	128	140	180	8	270,00
22 0392 0780 156	• 7,8	156	172	215	8	171,60
22 0392 0780 168	• 7,8	168	180	230	8	301,00
22 0392 0780 195	• 7,8	195	211	255	8	196,20
22 0392 0780 208	• 7,8	208	220	260	8	349,00
22 0392 0780 234	• 7,8	234	250	315	8	224,40
22 0392 0780 253	• 7,8	253	265	315	8	398,00
22 0392 0790 041	• 7,9	41	53	90	8	90,00
22 0392 0790 064	• 7,9	64	76	114	8	170,00
22 0392 0790 096	• 7,9	96	108	146	8	223,00
22 0392 0800 041	• 8,0	41	53	90	8	90,00
22 0392 0800 064	• 8,0	64	76	114	8	170,00
22 0392 0800 096	• 8,0	96	108	146	8	223,00
22 0392 0800 120	• 8,0	120	136	180	8	157,20
22 0392 0800 128	• 8,0	128	140	180	8	270,00
22 0392 0800 160	• 8,0	160	176	215	8	174,00
22 0392 0800 168	• 8,0	168	180	230	8	301,00
22 0392 0800 200	• 8,0	200	216	255	8	199,20
22 0392 0800 208	• 8,0	208	220	260	8	349,00
22 0392 0800 240	• 8,0	240	256	315	8	224,40
22 0392 0800 253	• 8,0	253	265	315	8	398,00
22 0392 0810 046	• 8,1	46	61	103	10	106,00
22 0392 0810 080	• 8,1	80	95	142	10	215,00
22 0392 0810 106	• 8,1	106	120	162	10	282,00

• Sonderpreis / Sale Artikel. Lieferbar solange Vorrat.  
Special price / sale article. While stocks last.

Art.	d1 h7	l3	l2	l1	d2 h6	€
22 0392 0820 046	• 8,2	46	61	103	10	106,00
22 0392 0820 080	• 8,2	80	95	142	10	215,00
22 0392 0820 106	• 8,2	106	120	162	10	282,00
22 0392 0830 046	• 8,3	46	61	103	10	106,00
22 0392 0830 080	• 8,3	80	95	142	10	215,00
22 0392 0830 106	• 8,3	106	120	162	10	282,00
22 0392 0840 046	• 8,4	46	61	103	10	106,00
22 0392 0840 080	• 8,4	80	95	142	10	215,00
22 0392 0840 106	• 8,4	106	120	162	10	282,00
22 0392 0850 046	• 8,5	46	61	103	10	106,00
22 0392 0850 080	• 8,5	80	95	142	10	215,00
22 0392 0850 106	• 8,5	106	120	162	10	282,00
22 0392 0850 128	• 8,5	128	145	190	10	168,00
22 0392 0850 146	• 8,5	146	160	205	10	300,00
22 0392 0850 170	• 8,5	170	187	230	10	190,20
22 0392 0850 182	• 8,5	182	195	260	10	334,00
22 0392 0850 212	• 8,5	212	230	285	10	224,40
22 0392 0850 227	• 8,5	227	240	285	10	392,00
22 0392 0850 255	• 8,5	255	272	315	10	258,60
22 0392 0850 282	• 8,5	282	295	350	10	460,00
22 0392 0860 046	• 8,6	46	61	103	10	106,00
22 0392 0860 080	• 8,6	80	95	142	10	215,00
22 0392 0860 106	• 8,6	106	120	162	10	282,00
22 0392 0870 046	• 8,7	46	61	103	10	106,00
22 0392 0870 080	• 8,7	80	95	142	10	215,00
22 0392 0870 106	• 8,7	106	120	162	10	282,00
22 0392 0880 046	• 8,8	46	61	103	10	106,00
22 0392 0880 080	• 8,8	80	95	142	10	215,00
22 0392 0880 106	• 8,8	106	120	162	10	282,00
22 0392 0880 132	• 8,8	132	150	200	10	190,20
22 0392 0880 146	• 8,8	146	160	205	10	334,00
22 0392 0880 176	• 8,8	176	193	240	10	208,80
22 0392 0880 215	• 8,8	215	230	290	10	370,00
22 0392 0880 220	• 8,8	220	238	310	10	243,00
22 0392 0880 253	• 8,8	253	268	310	10	427,00
22 0392 0880 264	• 8,8	264	281	325	10	274,20
22 0392 0880 315	• 8,8	315	330	380	10	485,00
22 0392 0890 046	• 8,9	46	61	103	10	106,00
22 0392 0890 080	• 8,9	80	95	142	10	215,00
22 0392 0890 106	• 8,9	106	120	162	10	282,00
22 0392 0900 046	• 9,0	46	61	103	10	106,00
22 0392 0900 080	• 9,0	80	95	142	10	215,00
22 0392 0900 106	• 9,0	106	120	162	10	282,00
22 0392 0900 135	• 9,0	135	153	200	10	190,20
22 0392 0900 146	• 9,0	146	160	205	10	334,00
22 0392 0900 180	• 9,0	180	198	250	10	208,80
22 0392 0900 215	• 9,0	215	230	290	10	370,00
22 0392 0900 225	• 9,0	225	243	310	10	246,60
22 0392 0900 253	• 9,0	253	268	310	10	427,00
22 0392 0900 270	• 9,0	270	288	335	10	274,20
22 0392 0900 315	• 9,0	315	330	380	10	485,00
22 0392 0910 046	• 9,1	46	61	103	10	106,00
22 0392 0910 080	• 9,1	80	95	142	10	215,00
22 0392 0910 138	• 9,1	138	156	204	10	381,00
22 0392 0920 046	• 9,2	46	61	103	10	106,00
22 0392 0920 080	• 9,2	80	95	142	10	215,00
22 0392 0920 138	• 9,2	138	156	204	10	381,00
22 0392 0930 046	• 9,3	46	61	103	10	106,00
22 0392 0930 080	• 9,3	80	95	142	10	215,00
22 0392 0930 138	• 9,3	138	156	204	10	381,00
22 0392 0940 046	• 9,4	46	61	103	10	106,00
22 0392 0940 080	• 9,4	80	95	142	10	215,00
22 0392 0940 138	• 9,4	138	156	204	10	381,00
22 0392 0950 046	• 9,5	46	61	103	10	106,00
22 0392 0950 080	• 9,5	80	95	142	10	215,00
22 0392 0950 138	• 9,5	138	156	204	10	381,00
22 0392 0960 046	• 9,6	46	61	103	10	106,00
22 0392 0960 080	• 9,6	80	95	142	10	215,00
22 0392 0960 138	• 9,6	138	156	204	10	381,00
22 0392 0970 046	• 9,7	46	61	103	10	106,00
22 0392 0970 080	• 9,7	80	95	142	10	215,00
22 0392 0970 138	• 9,7	138	156	204	10	381,00
22 0392 0980 046	• 9,8	46	61	103	10	106,00
22 0392 0980 080	• 9,8	80	95	142	10	215,00
22 0392 0980 138	• 9,8	138	156	204	10	381,00
22 0392 0980 147	• 9,8	147	166	215	10	187,20
22 0392 0980 165	• 9,8	165	180	225	10	334,00
22 0392 0980 196	• 9,8	196	215	265	10	208,80
22 0392 0980 215	• 9,8	215	230	290	10	370,00
22 0392 0980 245	• 9,8	245	264	310	10	246,60
22 0392 0980 253	• 9,8	253	268	310	10	427,00
22 0392 0980 294	• 9,8	294	313	360	10	279,00
22 0392 0980 315	• 9,8	315	330	380	10	485,00
22 0392 0990 046	• 9,9	46	61	103	10	106,00
22 0392 0990 080	• 9,9	80	95	142	10	215,00
22 0392 0990 138	• 9,9	138	156	204	10	381,00
22 0392 1000 046	• 10,0	46	61	103	10	106,00

Art.	d1 h7	l3	l2	l1	d2 h6	€
22 0392 1000 080	• 10,0	80	95	142	10	215,00
22 0392 1000 138	• 10,0	138	156	204	10	381,00
22 0392 1000 150	• 10,0	150	170	215	10	193,20
22 0392 1000 165	• 10,0	165	180	225	10	334,00
22 0392 1000 200	• 10,0	200	220	265	10	208,80
22 0392 1000 215	• 10,0	215	230	290	10	370,00
22 0392 1000 250	• 10,0	250	270	315	10	246,60
22 0392 1000 253	• 10,0	253	268	310	10	427,00
22 0392 1000 300	• 10,0	300	320	365	10	277,20
22 0392 1000 315	• 10,0	315	330	380	10	485,00
22 0392 1010 053	• 10,1	53	71	118	12	145,00
22 0392 1020 053	• 10,2	53	71	118	12	145,00
22 0392 1020 096	• 10,2	96	114	162	12	273,00
22 0392 1020 138	• 10,2	138	156	204	12	382,00
22 0392 1020 153	• 10,2	153	173	230	12	211,80
22 0392 1020 174	• 10,2	174	190	240	12	373,00
22 0392 1020 204	• 10,2	204	224	275	12	230,40
22 0392 1020 250	• 10,2	250	268	315	12	410,00
22 0392 1020 255	• 10,2	255	275	325	12	237,00
22 0392 1020 306	• 10,2	306	326	375	12	515,00
22 0392 1020 362	• 10,2	362	380	430	12	620,00
22 0392 1030 053	• 10,3	53	71	118	12	145,00
22 0392 1040 053	• 10,4	53	71	118	12	145,00
22 0392 1050 053	• 10,5	53	71	118	12	145,00
22 0392 1050 096	• 10,5	96	114	162	12	273,00
22 0392 1050 138	• 10,5	138	156	204	12	382,00
22 0392 1080 053	• 10,8	53	71	118	12	145,00
22 0392 1080 096	• 10,8	96	114	162	12	273,00
22 0392 1080 138	• 10,8	138	156	204	12	382,00
22 0392 1080 162	• 10,8	162	183	230	12	211,80
22 0392 1080 174	• 10,8	174	190	240	12	373,00
22 0392 1080 216	• 10,8	216	237	290	12	230,40
22 0392 1080 250	• 10,8	250	268	315	12	410,00
22 0392 1080 270	• 10,8	270	291	340	12	292,80
22 0392 1080 307	• 10,8	307	325	375	12	515,00
22 0392 1080 324	• 10,8	324	345	395	12	355,20
22 0392 1080 362	• 10,8	362	380	430	12	620,00
22 0392 1100 053	• 11,0	53	71	118	12	145,00
22 0392 1100 096	• 11,0	96	114	162	12	273,00
22 0392 1100 138	• 11,0	138	156	204	12	382,00
22 0392 1100 362	• 11,0	362	380	430	12	620,00
22 0392 1110 053	• 11,1	53	71	118	12	145,00
22 0392 1120 053	• 11,2	53	71	118	12	145,00
22 0392 1120 096	• 11,2	96	114	162	12	273,00
22 0392 1120 138	• 11,2	138	156	204	12	382,00
22 0392 1130 053	• 11,3	53	71	118	12	145,00
22 0392 1150 053	• 11,5	53	71	118	12	145,00
22 0392 1150 096	• 11,5	96	114	162	12	273,00
22 0392 1150 138	• 11,5	138	156	204	12	382,00
22 0392 1180 053	• 11,8	53	71	118	12	145,00
22 0392 1180 096	• 11,8	96	114	162	12	273,00
22 0392 1180 138	• 11,8	138	156	204	12	382,00
22 0392 1180 177	• 11,8	177	200	255	12	211,80
22 0392 1180 197	• 11,8	197	215	265	12	373,00
22 0392 1180 236	• 11,8	236	259	315	12	233,40
22 0392 1180 250	• 11,8	250	268	315	12	410,00
22 0392 1180 295	• 11,8	295	318	375	12	297,00
22 0392 1180 307	• 11,8	307	325	375	12	515,00
22 0392 1180 354	• 11,8	354	377	425	12	355,20
22 0392 1180 362	• 11,8	362	380	430	12	620,00
22 0392 1200 053	• 12,0	53	71	118	12	145,00
22 0392 1200 096	• 12,0	96	114	162	12	273,00
22 0392 1200 138	• 12,0	138	156	204	12	382,00
22 0392 1200 180	• 12,0	180	204	255	12	216,60
22 0392 1200 197	• 12,0	197	215	265	12	373,00
22 0392 1200 240	• 12,0	240	264	315	12	237,00
22 0392 1200 250	• 12,0	250	268	315	12	410,00
22 0392 1200 300	• 12,0	300	324	375	12	297,00



22 0802

VALUETOOL

Vollhartmetallbohrer  
Solid carbide twist drill

**STAHL**  
steel

**INOX**  
Edelstahl  
STAINLESS STEEL

**GJL**

**GJS**

**GTW**  
GTS

**HRC**  
**< 50**

kurz-  
spanend  
short chip

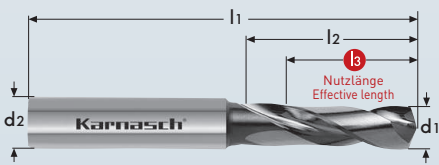
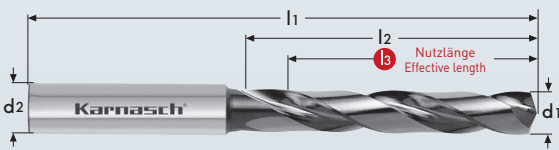

h7	Bohrungstoleranz Hole tolerance
> 3-6	+0,000
	-0,012
> 6-10	+0,000
	-0,015
>10-18	+0,000
	-0,018

<b>MICRO GRAIN</b>	<b>DIN 6537</b>
<b>N</b>	<b>DIN 6535 Form HA</b>
	<b>VTC</b>
	<b>TM-8</b>

Schnittdaten Cutting data	Zeichnungen Drawings
1252	DXF/STEP

Art.	d1 h7	l3	l2	l1	d2 h6	€
22 0802 0300 014	• 3,0	14	20	62	6,0	17,00
22 0802 0300 023	• 3,0	23	28	66	6,0	20,00
22 0802 0310 014	• 3,1	14	20	62	6,0	17,00
22 0802 0310 023	• 3,1	23	28	66	6,0	20,00
22 0802 0320 014	• 3,2	14	20	62	6,0	17,00
22 0802 0320 023	• 3,2	23	28	66	6,0	20,00
22 0802 0330 014	• 3,3	14	20	62	6,0	17,00
22 0802 0330 023	• 3,3	23	28	66	6,0	20,00
22 0802 0340 014	• 3,4	14	20	62	6,0	17,00
22 0802 0340 023	• 3,4	23	28	66	6,0	20,00
22 0802 0350 014	• 3,5	14	20	62	6,0	17,00
22 0802 0350 023	• 3,5	23	28	66	6,0	20,00
22 0802 0360 014	• 3,6	14	20	62	6,0	17,00
22 0802 0360 023	• 3,6	23	28	66	6,0	20,00
22 0802 0370 014	• 3,7	14	20	62	6,0	17,00
22 0802 0370 023	• 3,7	23	28	66	6,0	20,00
22 0802 0380 017	• 3,8	17	24	66	6,0	18,00
22 0802 0380 029	• 3,8	29	36	74	6,0	20,00
22 0802 0390 017	• 3,9	17	24	66	6,0	18,00
22 0802 0390 029	• 3,9	29	36	74	6,0	20,00
22 0802 0400 017	• 4,0	17	24	66	6,0	19,00
22 0802 0400 029	• 4,0	29	36	74	6,0	21,00
22 0802 0410 017	• 4,1	17	24	66	6,0	19,00
22 0802 0410 029	• 4,1	29	36	74	6,0	21,00
22 0802 0420 017	• 4,2	17	24	66	6,0	19,00
22 0802 0420 029	• 4,2	29	36	74	6,0	21,00
22 0802 0430 017	• 4,3	17	24	66	6,0	19,00
22 0802 0430 029	• 4,3	29	36	74	6,0	21,00
22 0802 0440 017	• 4,4	17	24	66	6,0	19,00
22 0802 0440 029	• 4,4	29	36	74	6,0	21,00
22 0802 0450 017	• 4,5	17	24	66	6,0	19,00
22 0802 0450 029	• 4,5	29	36	74	6,0	21,00
22 0802 0460 017	• 4,6	17	24	66	6,0	19,00
22 0802 0460 029	• 4,6	29	36	74	6,0	21,00
22 0802 0470 017	• 4,7	17	24	66	6,0	19,00
22 0802 0470 029	• 4,7	29	36	74	6,0	21,00
22 0802 0480 020	• 4,8	20	28	66	6,0	19,00
22 0802 0480 035	• 4,8	35	44	82	6,0	24,00
22 0802 0490 020	• 4,9	20	28	66	6,0	18,00
22 0802 0490 035	• 4,9	35	44	82	6,0	24,00
22 0802 0500 020	• 5,0	20	28	66	6,0	18,00
22 0802 0500 035	• 5,0	35	44	82	6,0	24,00

Art.	d1 h7	l3	l2	l1	d2 h6	€
22 0802 0510 020	• 5,1	20	28	66	6,0	18,00
22 0802 0510 035	• 5,1	35	44	82	6,0	24,00
22 0802 0520 020	• 5,2	20	28	66	6,0	18,00
22 0802 0520 035	• 5,2	35	44	82	6,0	24,00
22 0802 0530 020	• 5,3	20	28	66	6,0	18,00
22 0802 0530 035	• 5,3	35	44	82	6,0	24,00
22 0802 0540 020	• 5,4	20	28	66	6,0	18,00
22 0802 0540 035	• 5,4	35	44	82	6,0	24,00
22 0802 0550 020	• 5,5	20	28	66	6,0	18,00
22 0802 0550 035	• 5,5	35	44	82	6,0	26,00
22 0802 0560 020	• 5,6	20	28	66	6,0	19,00
22 0802 0560 035	• 5,6	35	44	82	6,0	26,00
22 0802 0570 020	• 5,7	20	28	66	6,0	19,00
22 0802 0570 035	• 5,7	35	44	82	6,0	26,00
22 0802 0580 020	• 5,8	20	28	66	6,0	19,00
22 0802 0580 035	• 5,8	35	44	82	6,0	26,00
22 0802 0590 020	• 5,9	20	28	66	6,0	19,00
22 0802 0590 035	• 5,9	35	44	82	6,0	26,00
22 0802 0600 020	• 6,0	20	28	66	6,0	19,00
22 0802 0600 035	• 6,0	35	44	82	6,0	26,00
22 0802 0610 024	• 6,1	24	34	79	8,0	25,00
22 0802 0610 043	• 6,1	43	53	91	8,0	36,00
22 0802 0620 024	• 6,2	24	34	79	8,0	25,00
22 0802 0620 043	• 6,2	43	53	91	8,0	36,00
22 0802 0630 024	• 6,3	24	34	79	8,0	25,00
22 0802 0630 043	• 6,3	43	53	91	8,0	36,00
22 0802 0640 024	• 6,4	24	34	79	8,0	25,00
22 0802 0640 043	• 6,4	43	53	91	8,0	36,00
22 0802 0650 024	• 6,5	24	34	79	8,0	25,00
22 0802 0650 043	• 6,5	43	53	91	8,0	36,00
22 0802 0660 024	• 6,6	24	34	79	8,0	25,00
22 0802 0660 043	• 6,6	43	53	91	8,0	36,00
22 0802 0670 024	• 6,7	24	34	79	8,0	25,00
22 0802 0670 043	• 6,7	43	53	91	8,0	36,00
22 0802 0680 024	• 6,8	24	34	79	8,0	25,00
22 0802 0680 043	• 6,8	43	53	91	8,0	36,00
22 0802 0690 024	• 6,9	24	34	79	8,0	24,00
22 0802 0690 043	• 6,9	43	53	91	8,0	37,00
22 0802 0700 024	• 7,0	24	34	79	8,0	25,00
22 0802 0700 043	• 7,0	43	53	91	8,0	37,00
22 0802 0710 029	• 7,1	29	41	79	8,0	25,00
22 0802 0710 043	• 7,1	43	53	91	8,0	37,00

Art.	d1 h7	l3	l2	l1	d2 h6	€
22 0802 0720 029	• 7,2	29	41	79	8,0	25,00
22 0802 0720 043	• 7,2	43	53	91	8,0	37,00
22 0802 0730 029	• 7,3	29	41	79	8,0	25,00
22 0802 0730 043	• 7,3	43	53	91	8,0	37,00
22 0802 0740 029	• 7,4	29	41	79	8,0	25,00
22 0802 0740 043	• 7,4	43	53	91	8,0	37,00
22 0802 0750 029	• 7,5	29	41	79	8,0	25,00
22 0802 0750 043	• 7,5	43	53	91	8,0	37,00
22 0802 0760 029	• 7,6	29	41	79	8,0	25,00
22 0802 0760 043	• 7,6	43	53	91	8,0	37,00
22 0802 0770 029	• 7,7	29	41	79	8,0	25,00
22 0802 0770 043	• 7,7	43	53	91	8,0	37,00
22 0802 0780 029	• 7,8	29	41	79	8,0	25,00
22 0802 0780 043	• 7,8	43	53	91	8,0	37,00
22 0802 0790 029	• 7,9	29	41	79	8,0	25,00
22 0802 0790 043	• 7,9	43	53	91	8,0	37,00
22 0802 0800 029	• 8,0	29	41	79	8,0	26,00
22 0802 0800 043	• 8,0	43	53	91	8,0	37,00
22 0802 0810 035	• 8,1	35	47	89	10,0	37,00
22 0802 0810 049	• 8,1	49	61	103	10,0	49,00
22 0802 0820 035	• 8,2	35	47	89	10,0	37,00
22 0802 0820 049	• 8,2	49	61	103	10,0	49,00
22 0802 0830 035	• 8,3	35	47	89	10,0	37,00
22 0802 0830 049	• 8,3	49	61	103	10,0	49,00
22 0802 0840 035	• 8,4	35	47	89	10,0	37,00
22 0802 0840 049	• 8,4	49	61	103	10,0	49,00
22 0802 0850 035	• 8,5	35	47	89	10,0	37,00
22 0802 0850 049	• 8,5	49	61	103	10,0	49,00
22 0802 0860 035	• 8,6	35	47	89	10,0	37,00
22 0802 0860 049	• 8,6	49	61	103	10,0	50,00
22 0802 0870 035	• 8,7	35	47	89	10,0	37,00
22 0802 0870 049	• 8,7	49	61	103	10,0	50,00
22 0802 0880 035	• 8,8	35	47	89	10,0	37,00
22 0802 0880 049	• 8,8	49	61	103	10,0	50,00
22 0802 0890 035	• 8,9	35	47	89	10,0	37,00
22 0802 0890 049	• 8,9	49	61	103	10,0	50,00
22 0802 0900 035	• 9,0	35	47	89	10,0	37,00
22 0802 0900 049	• 9,0	49	61	103	10,0	50,00
22 0802 0910 035	• 9,1	35	47	89	10,0	37,00
22 0802 0910 049	• 9,1	49	61	103	10,0	50,00
22 0802 0920 035	• 9,2	35	47	89	10,0	37,00
22 0802 0920 049	• 9,2	49	61	103	10,0	50,00
22 0802 0930 035	• 9,3	35	47	89	10,0	37,00
22 0802 0930 049	• 9,3	49	61	103	10,0	50,00
22 0802 0940 035	• 9,4	35	47	89	10,0	37,00
22 0802 0940 049	• 9,4	49	61	103	10,0	50,00
22 0802 0950 035	• 9,5	35	47	89	10,0	37,00
22 0802 0950 049	• 9,5	49	61	103	10,0	50,00
22 0802 0960 035	• 9,6	35	47	89	10,0	37,00
22 0802 0960 049	• 9,6	49	61	103	10,0	50,00
22 0802 0970 035	• 9,7	35	47	89	10,0	37,00
22 0802 0970 049	• 9,7	49	61	103	10,0	50,00
22 0802 0980 035	• 9,8	35	47	89	10,0	37,00
22 0802 0980 049	• 9,8	49	61	103	10,0	50,00
22 0802 0990 035	• 9,9	35	47	89	10,0	37,00
22 0802 0990 049	• 9,9	49	61	103	10,0	50,00
22 0802 1000 035	• 10,0	35	47	89	10,0	38,00
22 0802 1000 049	• 10,0	49	61	103	10,0	50,00
22 0802 1010 040	• 10,1	40	55	102	12,0	48,00
22 0802 1010 056	• 10,1	56	71	118	12,0	73,00
22 0802 1020 040	• 10,2	40	55	102	12,0	48,00
22 0802 1020 056	• 10,2	56	71	118	12,0	73,00
22 0802 1030 040	• 10,3	40	55	102	12,0	48,00
22 0802 1030 056	• 10,3	56	71	118	12,0	73,00
22 0802 1040 040	• 10,4	40	55	102	12,0	48,00
22 0802 1040 056	• 10,4	56	71	118	12,0	73,00
22 0802 1050 040	• 10,5	40	55	102	12,0	48,00
22 0802 1050 056	• 10,5	56	71	118	12,0	73,00
22 0802 1060 040	• 10,6	40	55	102	12,0	48,00
22 0802 1060 056	• 10,6	56	71	118	12,0	73,00
22 0802 1070 040	• 10,7	40	55	102	12,0	48,00
22 0802 1070 056	• 10,7	56	71	118	12,0	73,00
22 0802 1080 040	• 10,8	40	55	102	12,0	48,00
22 0802 1080 056	• 10,8	56	71	118	12,0	73,00
22 0802 1090 040	• 10,9	40	55	102	12,0	48,00
22 0802 1090 056	• 10,9	56	71	118	12,0	73,00
22 0802 1100 040	• 11,0	40	55	102	12,0	48,00
22 0802 1100 056	• 11,0	56	71	118	12,0	73,00
22 0802 1110 040	• 11,1	40	55	102	12,0	48,00
22 0802 1110 056	• 11,1	56	71	118	12,0	73,00
22 0802 1120 040	• 11,2	40	55	102	12,0	48,00
22 0802 1120 056	• 11,2	56	71	118	12,0	73,00

Art.	d1 h7	l3	l2	l1	d2 h6	€
22 0802 1130 040	• 11,3	40	55	102	12,0	48,00
22 0802 1130 056	• 11,3	56	71	118	12,0	73,00
22 0802 1140 040	• 11,4	40	55	102	12,0	48,00
22 0802 1140 056	• 11,4	56	71	118	12,0	73,00
22 0802 1150 040	• 11,5	40	55	102	12,0	48,00
22 0802 1150 056	• 11,5	56	71	118	12,0	73,00
22 0802 1160 040	• 11,6	40	55	102	12,0	48,00
22 0802 1160 056	• 11,6	56	71	118	12,0	73,00
22 0802 1170 040	• 11,7	40	55	102	12,0	48,00
22 0802 1170 056	• 11,7	56	71	118	12,0	73,00
22 0802 1180 040	• 11,8	40	55	102	12,0	48,00
22 0802 1180 056	• 11,8	56	71	118	12,0	73,00
22 0802 1190 040	• 11,9	40	55	102	12,0	48,00
22 0802 1190 056	• 11,9	56	71	118	12,0	73,00
22 0802 1200 040	• 12,0	40	55	102	12,0	49,00
22 0802 1200 056	• 12,0	56	71	118	12,0	73,00

Alternative 22 0402 auf Seite 254-255  
Alternative 22 0402 on page 254-255



22 0806

VALUETOOL

Vollhartmetallbohrer mit Innenkühlung  
Solid carbide twist drill with interior cooling supply

- 1
- 2
- 3
- 4
- 5
- 6
- 7
- 8
- 9

- STAHL**  
steel
- HRC < 50**
- INOX**  
Edelstahl  
STAINLESS STEEL
- kurzspanend  
short chip
- GJL**
- GJS**
- GTW**  
GTS

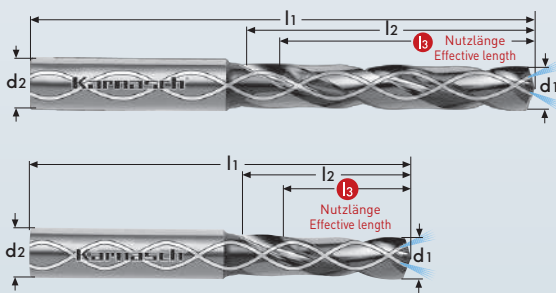

h7	Bohrungstoleranz Hole tolerance
> 3-6	+0,000 -0,012
> 6-10	+0,000 -0,015
> 10-18	+0,000 -0,018

- MICRO GRAIN**
- DIN 6537**
- N**
- DIN 6535**  
Form HA
- 30°
- 140°
- VTC**
- TM-8**

Schnittdaten  
Cutting data

Zeichnungen  
Drawings

1252

DXF/STEP

Art.	d1 h7	l3	l2	l1	d2 h6	€
22 0806 0300 014	• 3,0	14	20	62	6,0	21,00
22 0806 0300 023	• 3,0	23	28	66	6,0	25,00
22 0806 0310 014	• 3,1	14	20	62	6,0	21,00
22 0806 0310 023	• 3,1	23	28	66	6,0	25,00
22 0806 0320 014	• 3,2	14	20	62	6,0	21,00
22 0806 0320 023	• 3,2	23	28	66	6,0	25,00
22 0806 0330 014	• 3,3	14	20	62	6,0	21,00
22 0806 0330 023	• 3,3	23	28	66	6,0	25,00
22 0806 0340 014	• 3,4	14	20	62	6,0	21,00
22 0806 0340 023	• 3,4	23	28	66	6,0	25,00
22 0806 0350 014	• 3,5	14	20	62	6,0	21,00
22 0806 0350 023	• 3,5	23	28	66	6,0	25,00
22 0806 0360 014	• 3,6	14	20	62	6,0	21,00
22 0806 0360 023	• 3,6	23	28	66	6,0	25,00
22 0806 0370 014	• 3,7	14	20	62	6,0	21,00
22 0806 0370 023	• 3,7	23	28	66	6,0	25,00
22 0806 0380 017	• 3,8	17	24	66	6,0	23,00
22 0806 0380 029	• 3,8	29	36	74	6,0	25,00
22 0806 0390 017	• 3,9	17	24	66	6,0	23,00
22 0806 0390 029	• 3,9	29	36	74	6,0	25,00
22 0806 0400 017	• 4,0	17	24	66	6,0	23,00
22 0806 0400 029	• 4,0	29	36	74	6,0	26,00
22 0806 0410 017	• 4,1	17	24	66	6,0	23,00
22 0806 0410 029	• 4,1	29	36	74	6,0	26,00
22 0806 0420 017	• 4,2	17	24	66	6,0	23,00
22 0806 0420 029	• 4,2	29	36	74	6,0	26,00
22 0806 0430 017	• 4,3	17	24	66	6,0	23,00
22 0806 0430 029	• 4,3	29	36	74	6,0	26,00
22 0806 0440 017	• 4,4	17	24	66	6,0	23,00
22 0806 0440 029	• 4,4	29	36	74	6,0	26,00
22 0806 0450 017	• 4,5	17	24	66	6,0	23,00
22 0806 0450 029	• 4,5	29	36	74	6,0	26,00
22 0806 0460 017	• 4,6	17	24	66	6,0	23,00
22 0806 0460 029	• 4,6	29	36	74	6,0	26,00
22 0806 0470 017	• 4,7	17	24	66	6,0	23,00
22 0806 0470 029	• 4,7	29	36	74	6,0	26,00
22 0806 0480 020	• 4,8	20	28	66	6,0	23,00
22 0806 0480 035	• 4,8	35	44	82	6,0	30,00
22 0806 0490 020	• 4,9	20	28	66	6,0	23,00
22 0806 0490 035	• 4,9	35	44	82	6,0	30,00

Art.	d1 h7	l3	l2	l1	d2 h6	€
22 0806 0500 020	• 5,0	20	28	66	6,0	23,00
22 0806 0500 035	• 5,0	35	44	82	6,0	30,00
22 0806 0510 020	• 5,1	20	28	66	6,0	23,00
22 0806 0510 035	• 5,1	35	44	82	6,0	30,00
22 0806 0520 020	• 5,2	20	28	66	6,0	23,00
22 0806 0520 035	• 5,2	35	44	82	6,0	30,00
22 0806 0530 020	• 5,3	20	28	66	6,0	23,00
22 0806 0530 035	• 5,3	35	44	82	6,0	30,00
22 0806 0540 020	• 5,4	20	28	66	6,0	23,00
22 0806 0540 035	• 5,4	35	44	82	6,0	30,00
22 0806 0550 020	• 5,5	20	28	66	6,0	23,00
22 0806 0550 035	• 5,5	35	44	82	6,0	31,00
22 0806 0560 020	• 5,6	20	28	66	6,0	24,00
22 0806 0560 035	• 5,6	35	44	82	6,0	31,00
22 0806 0570 020	• 5,7	20	28	66	6,0	24,00
22 0806 0570 035	• 5,7	35	44	82	6,0	31,00
22 0806 0580 020	• 5,8	20	28	66	6,0	24,00
22 0806 0580 035	• 5,8	35	44	82	6,0	31,00
22 0806 0590 020	• 5,9	20	28	66	6,0	24,00
22 0806 0590 035	• 5,9	35	44	82	6,0	31,00
22 0806 0600 020	• 6,0	20	28	66	6,0	24,00
22 0806 0600 035	• 6,0	35	44	82	6,0	31,00
22 0806 0610 024	• 6,1	24	34	79	8,0	34,00
22 0806 0610 043	• 6,1	43	53	91	8,0	38,00
22 0806 0620 024	• 6,2	24	34	79	8,0	34,00
22 0806 0620 043	• 6,2	43	53	91	8,0	38,00
22 0806 0630 024	• 6,3	24	34	79	8,0	34,00
22 0806 0630 043	• 6,3	43	53	91	8,0	38,00
22 0806 0640 024	• 6,4	24	34	79	8,0	34,00
22 0806 0640 043	• 6,4	43	53	91	8,0	38,00
22 0806 0650 024	• 6,5	24	34	79	8,0	34,00
22 0806 0650 043	• 6,5	43	53	91	8,0	38,00
22 0806 0660 024	• 6,6	24	34	79	8,0	34,00
22 0806 0660 043	• 6,6	43	53	91	8,0	38,00
22 0806 0670 024	• 6,7	24	34	79	8,0	34,00
22 0806 0670 043	• 6,7	43	53	91	8,0	38,00
22 0806 0680 024	• 6,8	24	34	79	8,0	34,00
22 0806 0680 043	• 6,8	43	53	91	8,0	38,00
22 0806 0690 024	• 6,9	24	34	79	8,0	34,00
22 0806 0690 043	• 6,9	43	53	91	8,0	38,00



Art.	d1 h7	l3	l2	l1	d2 h6	€
22 0806 0700 024	• 7,0	24	34	79	8,0	34,00
22 0806 0700 043	• 7,0	43	53	91	8,0	38,00
22 0806 0710 029	• 7,1	29	41	79	8,0	34,00
22 0806 0710 043	• 7,1	43	53	91	8,0	38,00
22 0806 0720 029	• 7,2	29	41	79	8,0	34,00
22 0806 0720 043	• 7,2	43	53	91	8,0	38,00
22 0806 0730 029	• 7,3	29	41	79	8,0	34,00
22 0806 0730 043	• 7,3	43	53	91	8,0	38,00
22 0806 0740 029	• 7,4	29	41	79	8,0	34,00
22 0806 0740 043	• 7,4	43	53	91	8,0	38,00
22 0806 0750 029	• 7,5	29	41	79	8,0	34,00
22 0806 0750 043	• 7,5	43	53	91	8,0	38,00
22 0806 0760 029	• 7,6	29	41	79	8,0	34,00
22 0806 0760 043	• 7,6	43	53	91	8,0	38,00
22 0806 0770 029	• 7,7	29	41	79	8,0	34,00
22 0806 0770 043	• 7,7	43	53	91	8,0	38,00
22 0806 0780 029	• 7,8	29	41	79	8,0	34,00
22 0806 0780 043	• 7,8	43	53	91	8,0	38,00
22 0806 0790 029	• 7,9	29	41	79	8,0	34,00
22 0806 0790 043	• 7,9	43	53	91	8,0	38,00
22 0806 0800 029	• 8,0	29	41	79	8,0	34,00
22 0806 0800 043	• 8,0	43	53	91	8,0	38,00
22 0806 0810 035	• 8,1	35	47	89	10,0	44,00
22 0806 0810 049	• 8,1	49	61	103	10,0	47,00
22 0806 0820 035	• 8,2	35	47	89	10,0	44,00
22 0806 0820 049	• 8,2	49	61	103	10,0	47,00
22 0806 0830 035	• 8,3	35	47	89	10,0	44,00
22 0806 0830 049	• 8,3	49	61	103	10,0	47,00
22 0806 0840 035	• 8,4	35	47	89	10,0	44,00
22 0806 0840 049	• 8,4	49	61	103	10,0	47,00
22 0806 0850 035	• 8,5	35	47	89	10,0	44,00
22 0806 0850 049	• 8,5	49	61	103	10,0	47,00
22 0806 0860 035	• 8,6	35	47	89	10,0	44,00
22 0806 0860 049	• 8,6	49	61	103	10,0	47,00
22 0806 0870 035	• 8,7	35	47	89	10,0	44,00
22 0806 0870 049	• 8,7	49	61	103	10,0	47,00
22 0806 0880 035	• 8,8	35	47	89	10,0	44,00
22 0806 0880 049	• 8,8	49	61	103	10,0	47,00
22 0806 0890 035	• 8,9	35	47	89	10,0	44,00
22 0806 0890 049	• 8,9	49	61	103	10,0	47,00
22 0806 0900 035	• 9,0	35	47	89	10,0	44,00
22 0806 0900 049	• 9,0	49	61	103	10,0	47,00
22 0806 0910 035	• 9,1	35	47	89	10,0	44,00
22 0806 0910 049	• 9,1	49	61	103	10,0	47,00
22 0806 0920 035	• 9,2	35	47	89	10,0	44,00
22 0806 0920 049	• 9,2	49	61	103	10,0	48,00
22 0806 0930 035	• 9,3	35	47	89	10,0	44,00
22 0806 0930 049	• 9,3	49	61	103	10,0	48,00
22 0806 0940 035	• 9,4	35	47	89	10,0	44,00
22 0806 0940 049	• 9,4	49	61	103	10,0	48,00
22 0806 0950 035	• 9,5	35	47	89	10,0	44,00
22 0806 0950 049	• 9,5	49	61	103	10,0	48,00
22 0806 0960 035	• 9,6	35	47	89	10,0	44,00
22 0806 0960 049	• 9,6	49	61	103	10,0	48,00
22 0806 0970 035	• 9,7	35	47	89	10,0	44,00
22 0806 0970 049	• 9,7	49	61	103	10,0	48,00
22 0806 0980 035	• 9,8	35	47	89	10,0	44,00
22 0806 0980 049	• 9,8	49	61	103	10,0	48,00
22 0806 0990 035	• 9,9	35	47	89	10,0	44,00
22 0806 0990 049	• 9,9	49	61	103	10,0	48,00
22 0806 1000 035	• 10,0	35	47	89	10,0	46,00
22 0806 1000 049	• 10,0	49	61	103	10,0	48,00
22 0806 1010 040	• 10,1	40	55	102	12,0	61,00
22 0806 1010 056	• 10,1	56	71	118	12,0	79,00
22 0806 1020 040	• 10,2	40	55	102	12,0	61,00
22 0806 1020 056	• 10,2	56	71	118	12,0	79,00
22 0806 1030 040	• 10,3	40	55	102	12,0	61,00
22 0806 1030 056	• 10,3	56	71	118	12,0	79,00
22 0806 1040 040	• 10,4	40	55	102	12,0	61,00
22 0806 1040 056	• 10,4	56	71	118	12,0	79,00
22 0806 1050 040	• 10,5	40	55	102	12,0	61,00
22 0806 1050 056	• 10,5	56	71	118	12,0	79,00
22 0806 1060 040	• 10,6	40	55	102	12,0	61,00
22 0806 1060 056	• 10,6	56	71	118	12,0	79,00
22 0806 1070 040	• 10,7	40	55	102	12,0	61,00
22 0806 1070 056	• 10,7	56	71	118	12,0	79,00
22 0806 1080 040	• 10,8	40	55	102	12,0	61,00
22 0806 1080 056	• 10,8	56	71	118	12,0	79,00
22 0806 1090 040	• 10,9	40	55	102	12,0	61,00
22 0806 1090 056	• 10,9	56	71	118	12,0	79,00

Art.	d1 h7	l3	l2	l1	d2 h6	€
22 0806 1100 040	• 11,0	40	55	102	12,0	62,00
22 0806 1100 056	• 11,0	56	71	118	12,0	79,00
22 0806 1110 040	• 11,1	40	55	102	12,0	62,00
22 0806 1110 056	• 11,1	56	71	118	12,0	79,00
22 0806 1120 040	• 11,2	40	55	102	12,0	62,00
22 0806 1120 056	• 11,2	56	71	118	12,0	79,00
22 0806 1130 040	• 11,3	40	55	102	12,0	62,00
22 0806 1130 056	• 11,3	56	71	118	12,0	79,00
22 0806 1140 040	• 11,4	40	55	102	12,0	62,00
22 0806 1140 056	• 11,4	56	71	118	12,0	79,00
22 0806 1150 040	• 11,5	40	55	102	12,0	62,00
22 0806 1150 056	• 11,5	56	71	118	12,0	79,00
22 0806 1160 040	• 11,6	40	55	102	12,0	62,00
22 0806 1160 056	• 11,6	56	71	118	12,0	79,00
22 0806 1170 040	• 11,7	40	55	102	12,0	62,00
22 0806 1170 056	• 11,7	56	71	118	12,0	79,00
22 0806 1180 040	• 11,8	40	55	102	12,0	62,00
22 0806 1180 056	• 11,8	56	71	118	12,0	79,00
22 0806 1190 040	• 11,9	40	55	102	12,0	62,00
22 0806 1190 056	• 11,9	56	71	118	12,0	79,00
22 0806 1200 040	• 12,0	40	55	102	12,0	62,00
22 0806 1200 056	• 12,0	56	71	118	12,0	80,00

Alternative 22 0406 auf Seite 262-263  
Alternative 22 0406 on page 262-263



22 0402

Vollhartmetall-Hochleistungsbohrer  
Solid carbide high performance twist drill

**STAHL**  
steel

**INOX**  
Edelstahl  
STAINLESS STEEL

**GJL**

**GJS**

**GTW**  
GTS

**HRC**  
< 52

kurz-  
spanend  
short chip

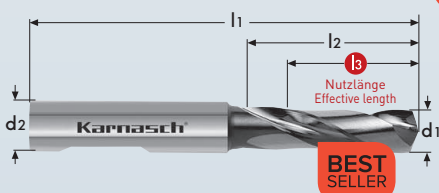
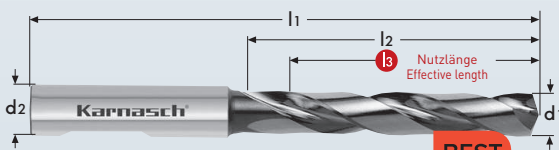

<b>MICRO GRAIN</b>	<b>DIN 6537</b>
<b>N</b>	<b>DIN 6535 Form HE</b>
	<b>HSC HPC</b>
	<b>DVC-X2</b>

Schnittdaten  
Cutting data

Zeichnungen  
Drawings



Bestseller - Preis reduziert · Bestseller - Price reduced

Art.	d1 m7	l3	l2	l1	d2 h6	€
22 0402 0300 014	• 3,0	14	20	62	6,0	33,00
22 0402 0300 023	• 3,0	23	28	66	6,0	41,00
22 0402 0310 014	• 3,1	14	20	62	6,0	33,00
22 0402 0310 023	• 3,1	23	28	66	6,0	41,00
22 0402 0320 014	• 3,2	14	20	62	6,0	33,00
22 0402 0320 023	• 3,2	23	28	66	6,0	41,00
22 0402 0330 014	• 3,3	14	20	62	6,0	33,00
22 0402 0330 023	• 3,3	23	28	66	6,0	41,00
22 0402 0340 014	• 3,4	14	20	62	6,0	33,00
22 0402 0340 023	• 3,4	23	28	66	6,0	41,00
22 0402 0350 014	• 3,5	14	20	62	6,0	33,00
22 0402 0350 023	• 3,5	23	28	66	6,0	41,00
22 0402 0360 014	• 3,6	14	20	62	6,0	33,00
22 0402 0360 023	• 3,6	23	28	66	6,0	41,00
22 0402 0370 014	• 3,7	14	20	62	6,0	33,00
22 0402 0370 023	• 3,7	23	28	66	6,0	41,00
22 0402 0380 017	• 3,8	17	24	66	6,0	33,00
22 0402 0380 029	• 3,8	29	36	74	6,0	41,00
22 0402 0390 017	• 3,9	17	24	66	6,0	33,00
22 0402 0390 029	• 3,9	29	36	74	6,0	41,00
22 0402 0400 017	• 4,0	17	24	66	6,0	33,00
22 0402 0400 029	• 4,0	29	36	74	6,0	41,00
22 0402 0410 017	• 4,1	17	24	66	6,0	33,00
22 0402 0410 029	• 4,1	29	36	74	6,0	41,00
22 0402 0420 017	• 4,2	17	24	66	6,0	33,00
22 0402 0420 029	• 4,2	29	36	74	6,0	41,00
22 0402 0430 017	• 4,3	17	24	66	6,0	33,00
22 0402 0430 029	• 4,3	29	36	74	6,0	41,00
22 0402 0440 017	• 4,4	17	24	66	6,0	33,00
22 0402 0440 029	• 4,4	29	36	74	6,0	41,00
22 0402 0450 017	• 4,5	17	24	66	6,0	33,00
22 0402 0450 029	• 4,5	29	36	74	6,0	41,00
22 0402 0460 017	• 4,6	17	24	66	6,0	33,00
22 0402 0460 029	• 4,6	29	36	74	6,0	41,00
22 0402 0470 017	• 4,7	17	24	66	6,0	33,00
22 0402 0470 029	• 4,7	29	36	74	6,0	41,00
22 0402 0480 020	• 4,8	20	28	66	6,0	33,00
22 0402 0480 035	• 4,8	35	44	82	6,0	41,00
22 0402 0490 020	• 4,9	20	28	66	6,0	33,00
22 0402 0490 035	• 4,9	35	44	82	6,0	41,00
22 0402 0500 020	• 5,0	20	28	66	6,0	33,00
22 0402 0500 035	• 5,0	35	44	82	6,0	41,00

Art.	d1 m7	l3	l2	l1	d2 h6	€
22 0402 0510 020	• 5,1	20	28	66	6,0	33,00
22 0402 0510 035	• 5,1	35	44	82	6,0	41,00
22 0402 0520 020	• 5,2	20	28	66	6,0	33,00
22 0402 0520 035	• 5,2	35	44	82	6,0	41,00
22 0402 0530 020	• 5,3	20	28	66	6,0	33,00
22 0402 0530 035	• 5,3	35	44	82	6,0	41,00
22 0402 0540 020	• 5,4	20	28	66	6,0	33,00
22 0402 0540 035	• 5,4	35	44	82	6,0	41,00
22 0402 0550 020	• 5,5	20	28	66	6,0	33,00
22 0402 0550 035	• 5,5	35	44	82	6,0	41,00
22 0402 0560 020	• 5,6	20	28	66	6,0	33,00
22 0402 0560 035	• 5,6	35	44	82	6,0	41,00
22 0402 0570 020	• 5,7	20	28	66	6,0	33,00
22 0402 0570 035	• 5,7	35	44	82	6,0	41,00
22 0402 0580 020	• 5,8	20	28	66	6,0	33,00
22 0402 0580 035	• 5,8	35	44	82	6,0	41,00
22 0402 0590 020	• 5,9	20	28	66	6,0	33,00
22 0402 0590 035	• 5,9	35	44	82	6,0	41,00
22 0402 0600 020	• 6,0	20	28	66	6,0	33,00
22 0402 0600 035	• 6,0	35	44	82	6,0	41,00
22 0402 0610 024	• 6,1	24	34	79	8,0	40,00
22 0402 0610 043	• 6,1	43	53	91	8,0	45,00
22 0402 0620 024	• 6,2	24	34	79	8,0	40,00
22 0402 0620 043	• 6,2	43	53	91	8,0	45,00
22 0402 0630 024	• 6,3	24	34	79	8,0	40,00
22 0402 0630 043	• 6,3	43	53	91	8,0	45,00
22 0402 0640 024	• 6,4	24	34	79	8,0	40,00
22 0402 0640 043	• 6,4	43	53	91	8,0	45,00
22 0402 0650 024	• 6,5	24	34	79	8,0	40,00
22 0402 0650 043	• 6,5	43	53	91	8,0	45,00
22 0402 0660 024	• 6,6	24	34	79	8,0	40,00
22 0402 0660 043	• 6,6	43	53	91	8,0	45,00
22 0402 0670 024	• 6,7	24	34	79	8,0	40,00
22 0402 0670 043	• 6,7	43	53	91	8,0	45,00
22 0402 0680 024	• 6,8	24	34	79	8,0	40,00
22 0402 0680 043	• 6,8	43	53	91	8,0	45,00
22 0402 0690 024	• 6,9	24	34	79	8,0	40,00
22 0402 0690 043	• 6,9	43	53	91	8,0	45,00
22 0402 0700 024	• 7,0	24	34	79	8,0	40,00
22 0402 0700 043	• 7,0	43	53	91	8,0	45,00
22 0402 0710 029	• 7,1	29	41	79	8,0	40,00
22 0402 0710 043	• 7,1	43	53	91	8,0	45,00

Art.	d1 m7	l3	l2	l1	d2 h6	€
22 0402 0720 029	• 7,2	29	41	79	8,0	40,00
22 0402 0720 043	• 7,2	43	53	91	8,0	45,00
22 0402 0730 029	• 7,3	29	41	79	8,0	40,00
22 0402 0730 043	• 7,3	43	53	91	8,0	45,00
22 0402 0740 029	• 7,4	29	41	79	8,0	40,00
22 0402 0740 043	• 7,4	43	53	91	8,0	45,00
22 0402 0750 029	• 7,5	29	41	79	8,0	40,00
22 0402 0750 043	• 7,5	43	53	91	8,0	45,00
22 0402 0760 029	• 7,6	29	41	79	8,0	40,00
22 0402 0760 043	• 7,6	43	53	91	8,0	45,00
22 0402 0770 029	• 7,7	29	41	79	8,0	40,00
22 0402 0770 043	• 7,7	43	53	91	8,0	45,00
22 0402 0780 029	• 7,8	29	41	79	8,0	40,00
22 0402 0780 043	• 7,8	43	53	91	8,0	45,00
22 0402 0790 029	• 7,9	29	41	79	8,0	40,00
22 0402 0790 043	• 7,9	43	53	91	8,0	45,00
22 0402 0800 029	• 8,0	29	41	79	8,0	40,00
22 0402 0800 043	• 8,0	43	53	91	8,0	45,00
22 0402 0810 035	• 8,1	35	47	89	10,0	45,00
22 0402 0810 049	• 8,1	49	61	103	10,0	51,00
22 0402 0820 035	• 8,2	35	47	89	10,0	45,00
22 0402 0820 049	• 8,2	49	61	103	10,0	51,00
22 0402 0830 035	• 8,3	35	47	89	10,0	45,00
22 0402 0830 049	• 8,3	49	61	103	10,0	51,00
22 0402 0840 035	• 8,4	35	47	89	10,0	45,00
22 0402 0840 049	• 8,4	49	61	103	10,0	51,00
22 0402 0850 035	• 8,5	35	47	89	10,0	45,00
22 0402 0850 049	• 8,5	49	61	103	10,0	51,00
22 0402 0860 035	• 8,6	35	47	89	10,0	45,00
22 0402 0860 049	• 8,6	49	61	103	10,0	51,00
22 0402 0870 035	• 8,7	35	47	89	10,0	45,00
22 0402 0870 049	• 8,7	49	61	103	10,0	51,00
22 0402 0880 035	• 8,8	35	47	89	10,0	45,00
22 0402 0880 049	• 8,8	49	61	103	10,0	51,00
22 0402 0890 035	• 8,9	35	47	89	10,0	45,00
22 0402 0890 049	• 8,9	49	61	103	10,0	51,00
22 0402 0900 035	• 9,0	35	47	89	10,0	45,00
22 0402 0900 049	• 9,0	49	61	103	10,0	51,00
22 0402 0910 035	• 9,1	35	47	89	10,0	45,00
22 0402 0910 049	• 9,1	49	61	103	10,0	51,00
22 0402 0920 035	• 9,2	35	47	89	10,0	45,00
22 0402 0920 049	• 9,2	49	61	103	10,0	51,00
22 0402 0930 035	• 9,3	35	47	89	10,0	45,00
22 0402 0930 049	• 9,3	49	61	103	10,0	51,00
22 0402 0940 035	• 9,4	35	47	89	10,0	45,00
22 0402 0940 049	• 9,4	49	61	103	10,0	51,00
22 0402 0950 035	• 9,5	35	47	89	10,0	45,00
22 0402 0950 049	• 9,5	49	61	103	10,0	51,00
22 0402 0960 035	• 9,6	35	47	89	10,0	45,00
22 0402 0960 049	• 9,6	49	61	103	10,0	51,00
22 0402 0970 035	• 9,7	35	47	89	10,0	45,00
22 0402 0970 049	• 9,7	49	61	103	10,0	51,00
22 0402 0980 035	• 9,8	35	47	89	10,0	45,00
22 0402 0980 049	• 9,8	49	61	103	10,0	51,00
22 0402 0990 035	• 9,9	35	47	89	10,0	45,00
22 0402 0990 049	• 9,9	49	61	103	10,0	51,00
22 0402 1000 035	• 10,0	35	47	89	10,0	45,00
22 0402 1000 049	• 10,0	49	61	103	10,0	51,00
22 0402 1010 040	• 10,1	40	55	102	12,0	67,00
22 0402 1010 056	• 10,1	56	71	118	12,0	75,00
22 0402 1020 040	• 10,2	40	55	102	12,0	67,00
22 0402 1020 056	• 10,2	56	71	118	12,0	75,00
22 0402 1030 040	• 10,3	40	55	102	12,0	67,00
22 0402 1030 056	• 10,3	56	71	118	12,0	75,00
22 0402 1040 040	• 10,4	40	55	102	12,0	67,00
22 0402 1040 056	• 10,4	56	71	118	12,0	75,00
22 0402 1050 040	• 10,5	40	55	102	12,0	67,00
22 0402 1050 056	• 10,5	56	71	118	12,0	75,00
22 0402 1060 040	• 10,6	40	55	102	12,0	67,00
22 0402 1060 056	• 10,6	56	71	118	12,0	75,00
22 0402 1070 040	• 10,7	40	55	102	12,0	67,00
22 0402 1070 056	• 10,7	56	71	118	12,0	75,00
22 0402 1080 040	• 10,8	40	55	102	12,0	67,00
22 0402 1080 056	• 10,8	56	71	118	12,0	75,00
22 0402 1090 040	• 10,9	40	55	102	12,0	67,00
22 0402 1090 056	• 10,9	56	71	118	12,0	75,00
22 0402 1100 040	• 11,0	40	55	102	12,0	67,00
22 0402 1100 056	• 11,0	56	71	118	12,0	75,00
22 0402 1110 040	• 11,1	40	55	102	12,0	67,00
22 0402 1110 056	• 11,1	56	71	118	12,0	75,00
22 0402 1120 040	• 11,2	40	55	102	12,0	67,00
22 0402 1120 056	• 11,2	56	71	118	12,0	75,00

Art.	d1 m7	l3	l2	l1	d2 h6	€
22 0402 1130 040	• 11,3	40	55	102	12,0	67,00
22 0402 1130 056	• 11,3	56	71	118	12,0	75,00
22 0402 1140 040	• 11,4	40	55	102	12,0	67,00
22 0402 1140 056	• 11,4	56	71	118	12,0	75,00
22 0402 1150 040	• 11,5	40	55	102	12,0	67,00
22 0402 1150 056	• 11,5	56	71	118	12,0	75,00
22 0402 1160 040	• 11,6	40	55	102	12,0	67,00
22 0402 1160 056	• 11,6	56	71	118	12,0	75,00
22 0402 1170 040	• 11,7	40	55	102	12,0	67,00
22 0402 1170 056	• 11,7	56	71	118	12,0	75,00
22 0402 1180 040	• 11,8	40	55	102	12,0	67,00
22 0402 1180 056	• 11,8	56	71	118	12,0	75,00
22 0402 1190 040	• 11,9	40	55	102	12,0	67,00
22 0402 1190 056	• 11,9	56	71	118	12,0	75,00
22 0402 1200 040	• 12,0	40	55	102	12,0	67,00
22 0402 1200 056	• 12,0	56	71	118	12,0	75,00
22 0402 1250 043	• 12,5	43	60	107	14,0	88,00
22 0402 1250 060	• 12,5	60	77	124	14,0	98,00
22 0402 1280 043	• 12,8	43	60	107	14,0	88,00
22 0402 1280 060	• 12,8	60	77	124	14,0	98,00
22 0402 1300 043	• 13,0	43	60	107	14,0	88,00
22 0402 1300 060	• 13,0	60	60	124	14,0	98,00
22 0402 1350 043	• 13,5	43	60	107	14,0	88,00
22 0402 1350 060	• 13,5	60	77	124	14,0	98,00
22 0402 1380 043	• 13,8	43	60	107	14,0	88,00
22 0402 1380 060	• 13,8	60	77	124	14,0	98,00
22 0402 1400 043	• 14,0	43	60	107	14,0	88,00
22 0402 1400 060	• 14,0	60	77	124	14,0	98,00
22 0402 1450 045	• 14,5	45	65	115	16,0	112,00
22 0402 1450 063	• 14,5	63	83	133	16,0	130,00
22 0402 1480 045	• 14,8	45	65	115	16,0	112,00
22 0402 1480 063	• 14,8	63	83	133	16,0	130,00
22 0402 1500 045	• 15,0	45	65	115	16,0	112,00
22 0402 1500 063	• 15,0	63	83	133	16,0	130,00
22 0402 1550 045	• 15,5	45	65	115	16,0	112,00
22 0402 1550 063	• 15,5	63	83	133	16,0	130,00
22 0402 1580 045	• 15,8	45	65	115	16,0	112,00
22 0402 1580 063	• 15,8	63	83	133	16,0	130,00
22 0402 1600 045	• 16,0	45	65	115	16,0	112,00
22 0402 1600 063	• 16,0	63	83	133	16,0	130,00
22 0402 1880 055	• 18,8	55	79	131	20,0	120,00

Nachfolgewerkzeug 22 0405 auf Seite 259-261  
 Replacement article 22 0405 on page 259-261

🎯 Sonderpreis / Sale Artikel. Lieferbar solange Vorrat.  
 Special price / sale article. While stocks last.

1  
2  
3  
4  
5  
6 MACHINERIE  
7 OIL  
8  
9  
Index

## 22 0403

Vollhartmetall-Hochleistungsbohrer / für Bohrung H7 / 2 Fasen  
Solid carbide twist drill / for drill hole tolerances H7 / 2 chamfer

- 1
- 2
- 3
- 4
- 5
- 6
- 7
- 8
- 9

**STAHL**  
steel

**INOX**  
Edelstahl  
STAINLESS STEEL

**GJL**

**GJS**

**GTW**  
GTS

**HRC**  
< 52

**kurz-**  
**spanend**  
short chip

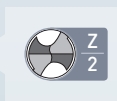
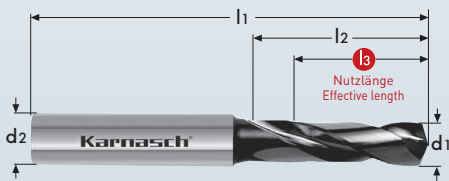

H7	Bohrungstoleranz Hole tolerance		
3-6	-0/+0,012	10-18	-0/+0,018
6-10	-0/+0,015	18-30	-0/+0,021

Art.	d1 H7	l3	l2	l1	d2 h6	€
22 0403 0300 014	• 3,0	14	20	62	6,0	41,00
22 0403 0400 017	• 4,0	17	24	66	6,0	41,00
22 0403 0500 020	• 5,0	20	28	66	6,0	41,00
22 0403 0600 020	• 6,0	20	28	66	6,0	41,00
22 0403 0700 024	• 7,0	24	34	79	8,0	49,00
22 0403 0800 029	• 8,0	29	41	79	8,0	49,00
22 0403 0900 035	• 9,0	35	47	89	10,0	54,00
22 0403 1000 035	• 10,0	35	47	89	10,0	54,00
22 0403 1200 040	• 12,0	40	55	102	12,0	83,00

<b>MICRO GRAIN</b>	<b>DIN 6537</b>
<b>N</b>	<b>DIN 6535 Form HA</b>
	<b>HSC HPC</b>
	<b>XFN-2 NANO</b>

Schnittdaten Cutting data	Zeichnungen Drawings
1252	DXF/STEP

## 22 0403



Vollhartmetall-Hochleistungsflachkopfborher für Stahl, 180°  
Solid carbide shallow drill 180° for steel

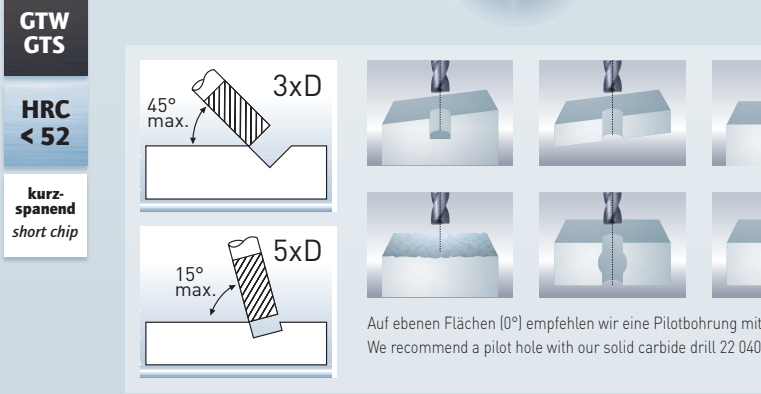
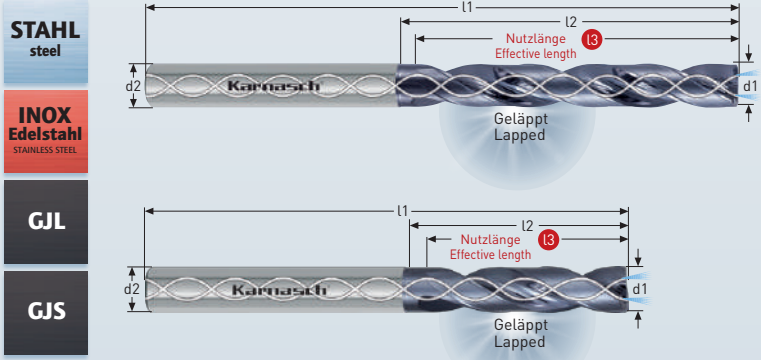

Auf ebenen Flächen [0°] empfehlen wir eine Pilotbohrung mit unserem VHM-Borher 22 0405 / 22 0406.  
We recommend a pilot hole with our solid carbide drill 22 0405 / 22 0406 on flat surfaces [0°].

**MICRO GRAIN**  
**KARNASCH NORM**

**N**  
**DIN 6535 Form HAK**

**HSC HPC**

**DMC-X2**

Schnittdaten  
Cutting data

Zeichnungen  
Drawings

**1242**

**DXF/STEP**

Art.	d1 m7	l3	l2	l1	d2 h6	€
22 0404 0300 014	• 3,00	14	20	62	6,0	91,00
22 0404 0300 023	• 3,00	23	28	66	6,0	109,00
22 0404 0320 014	• 3,20	14	20	62	6,0	91,00
22 0404 0320 023	• 3,20	23	28	66	6,0	109,00
22 0404 0330 014	• 3,30	14	20	62	6,0	91,00
22 0404 0330 023	• 3,30	23	28	66	6,0	109,00
22 0404 0340 014	• 3,40	14	20	62	6,0	91,00
22 0404 0340 023	• 3,40	23	28	66	6,0	109,00
22 0404 0350 014	• 3,50	14	20	62	6,0	91,00
22 0404 0350 023	• 3,50	23	28	66	6,0	109,00
22 0404 0370 017	• 3,70	17	20	62	6,0	91,00
22 0404 0370 023	• 3,70	23	28	66	6,0	109,00
22 0404 0380 017	• 3,80	17	24	66	6,0	91,00
22 0404 0380 029	• 3,80	29	36	74	6,0	109,00
22 0404 0390 017	• 3,90	17	24	66	6,0	91,00
22 0404 0390 029	• 3,90	29	36	74	6,0	109,00
22 0404 0400 017	• 4,00	17	24	66	6,0	91,00
22 0404 0400 029	• 4,00	29	36	74	6,0	109,00
22 0404 0420 017	• 4,20	17	24	66	6,0	91,00
22 0404 0420 029	• 4,20	29	36	74	6,0	109,00
22 0404 0430 017	• 4,30	17	24	66	6,0	91,00
22 0404 0430 029	• 4,30	29	36	74	6,0	109,00
22 0404 0450 017	• 4,50	17	24	66	6,0	91,00
22 0404 0450 029	• 4,50	29	36	74	6,0	109,00
22 0404 0465 017	• 4,65	17	24	66	6,0	91,00
22 0404 0465 029	• 4,65	29	36	74	6,0	109,00
22 0404 0480 020	• 4,80	20	28	66	6,0	91,00
22 0404 0480 035	• 4,80	35	44	82	6,0	109,00
22 0404 0500 020	• 5,00	20	28	66	6,0	91,00
22 0404 0500 035	• 5,00	35	44	82	6,0	109,00
22 0404 0510 020	• 5,10	20	28	66	6,0	91,00
22 0404 0510 035	• 5,10	35	44	82	6,0	109,00
22 0404 0520 020	• 5,20	20	28	66	6,0	91,00
22 0404 0520 035	• 5,20	35	44	82	6,0	109,00
22 0404 0530 020	• 5,30	20	28	66	6,0	91,00
22 0404 0530 035	• 5,30	35	44	82	6,0	109,00
22 0404 0540 020	• 5,40	20	28	66	6,0	91,00
22 0404 0540 035	• 5,40	35	44	82	6,0	109,00
22 0404 0550 020	• 5,50	20	28	66	6,0	91,00
22 0404 0550 035	• 5,50	35	44	82	6,0	109,00
22 0404 0555 020	• 5,55	20	28	66	6,0	91,00
22 0404 0555 035	• 5,55	35	44	82	6,0	109,00
22 0404 0560 020	• 5,60	20	28	66	6,0	91,00
22 0404 0560 035	• 5,60	35	44	82	6,0	109,00

Art.	d1 m7	l3	l2	l1	d2 h6	€
22 0404 0570 020	• 5,70	20	28	66	6,0	91,00
22 0404 0570 035	• 5,70	35	44	82	6,0	109,00
22 0404 0580 020	• 5,80	20	28	66	6,0	91,00
22 0404 0580 035	• 5,80	35	44	82	6,0	109,00
22 0404 0600 020	• 6,00	20	28	66	6,0	91,00
22 0404 0600 035	• 6,00	35	44	82	6,0	109,00
22 0404 0610 024	• 6,10	24	34	79	8,0	111,00
22 0404 0610 043	• 6,10	43	53	91	8,0	120,00
22 0404 0620 024	• 6,20	24	34	79	8,0	111,00
22 0404 0620 043	• 6,20	43	53	91	8,0	120,00
22 0404 0630 024	• 6,30	24	34	79	8,0	111,00
22 0404 0630 043	• 6,30	43	53	91	8,0	120,00
22 0404 0640 024	• 6,40	24	34	79	8,0	111,00
22 0404 0640 043	• 6,40	43	53	91	8,0	120,00
22 0404 0650 024	• 6,50	24	34	79	8,0	111,00
22 0404 0650 043	• 6,50	43	53	91	8,0	120,00
22 0404 0660 024	• 6,60	24	34	79	8,0	111,00
22 0404 0660 043	• 6,60	43	53	91	8,0	120,00
22 0404 0670 024	• 6,70	24	34	79	8,0	111,00
22 0404 0670 043	• 6,70	43	53	91	8,0	120,00
22 0404 0680 024	• 6,80	24	34	79	8,0	111,00
22 0404 0680 043	• 6,80	43	53	91	8,0	120,00
22 0404 0690 024	• 6,90	24	34	79	8,0	111,00
22 0404 0690 043	• 6,90	43	53	91	8,0	120,00
22 0404 0700 024	• 7,00	24	34	79	8,0	111,00
22 0404 0700 043	• 7,00	43	53	91	8,0	120,00
22 0404 0710 029	• 7,10	29	41	79	8,0	111,00
22 0404 0710 043	• 7,10	43	53	91	8,0	120,00
22 0404 0720 029	• 7,20	29	41	79	8,0	111,00
22 0404 0720 043	• 7,20	43	53	91	8,0	120,00
22 0404 0730 029	• 7,30	29	41	79	8,0	111,00
22 0404 0730 043	• 7,30	43	53	91	8,0	120,00
22 0404 0740 029	• 7,40	29	41	79	8,0	111,00
22 0404 0740 043	• 7,40	43	53	91	8,0	120,00
22 0404 0750 029	• 7,50	29	41	79	8,0	111,00
22 0404 0750 043	• 7,50	43	53	91	8,0	120,00
22 0404 0760 029	• 7,60	29	41	79	8,0	111,00
22 0404 0760 043	• 7,60	43	53	91	8,0	120,00
22 0404 0780 029	• 7,80	29	41	79	8,0	111,00
22 0404 0780 043	• 7,80	43	53	91	8,0	120,00
22 0404 0790 029	• 7,90	29	41	79	8,0	111,00
22 0404 0790 043	• 7,90	43	53	91	8,0	120,00
22 0404 0800 029	• 8,00	29	41	79	8,0	111,00
22 0404 0800 043	• 8,00	43	53	91	8,0	120,00

1

2

3

4

5

6

7

8

9



22 0404

Art.	d1 m7	l3	l2	l1	d2 h6	€
22 0404 0810 035	• 8,10	35	47	89	10,0	151,00
22 0404 0810 049	• 8,10	49	61	103	10,0	173,00
22 0404 0820 035	• 8,20	35	47	89	10,0	151,00
22 0404 0820 049	• 8,20	49	61	103	10,0	173,00
22 0404 0830 035	• 8,30	35	47	89	10,0	151,00
22 0404 0830 049	• 8,30	49	61	103	10,0	173,00
22 0404 0840 035	• 8,40	35	47	89	10,0	151,00
22 0404 0840 049	• 8,40	49	61	103	10,0	173,00
22 0404 0850 035	• 8,50	35	47	89	10,0	151,00
22 0404 0850 049	• 8,50	49	61	103	10,0	173,00
22 0404 0860 035	• 8,60	35	47	89	10,0	151,00
22 0404 0860 049	• 8,60	49	61	103	10,0	173,00
22 0404 0870 035	• 8,70	35	47	89	10,0	151,00
22 0404 0870 049	• 8,70	49	61	103	10,0	173,00
22 0404 0880 035	• 8,80	35	47	89	10,0	151,00
22 0404 0880 049	• 8,80	49	61	103	10,0	173,00
22 0404 0890 035	• 8,90	35	47	89	10,0	151,00
22 0404 0890 049	• 8,90	49	61	103	10,0	173,00
22 0404 0900 035	• 9,00	35	47	89	10,0	151,00
22 0404 0900 049	• 9,00	49	61	103	10,0	173,00
22 0404 0910 035	• 9,10	35	47	89	10,0	151,00
22 0404 0910 049	• 9,10	49	61	103	10,0	173,00
22 0404 0920 035	• 9,20	35	47	89	10,0	151,00
22 0404 0920 049	• 9,20	49	61	103	10,0	173,00
22 0404 0930 035	• 9,30	35	47	89	10,0	151,00
22 0404 0930 049	• 9,30	49	61	103	10,0	173,00
22 0404 0950 035	• 9,50	35	47	89	10,0	151,00
22 0404 0950 049	• 9,50	49	61	103	10,0	173,00
22 0404 0960 035	• 9,60	35	47	89	10,0	151,00
22 0404 0960 049	• 9,60	49	61	103	10,0	173,00
22 0404 0970 035	• 9,70	35	47	89	10,0	151,00
22 0404 0970 049	• 9,70	49	61	103	10,0	173,00
22 0404 0980 035	• 9,80	35	47	89	10,0	151,00
22 0404 0980 049	• 9,80	49	61	103	10,0	173,00
22 0404 1000 035	• 10,00	35	47	89	10,0	151,00
22 0404 1000 049	• 10,00	49	61	103	10,0	173,00
22 0404 1010 040	• 10,10	40	53	100	12,0	193,00
22 0404 1010 056	• 10,10	56	69	116	12,0	243,00
22 0404 1020 040	• 10,20	40	53	100	12,0	193,00
22 0404 1020 056	• 10,20	56	69	116	12,0	243,00
22 0404 1030 040	• 10,30	40	53	100	12,0	193,00
22 0404 1030 056	• 10,30	56	69	116	12,0	243,00
22 0404 1050 040	• 10,50	40	53	100	12,0	193,00
22 0404 1050 056	• 10,50	56	69	116	12,0	243,00
22 0404 1060 040	• 10,60	40	53	100	12,0	193,00
22 0404 1060 056	• 10,60	56	69	116	12,0	243,00
22 0404 1070 040	• 10,70	40	53	100	12,0	193,00
22 0404 1070 056	• 10,70	56	69	116	12,0	243,00
22 0404 1080 040	• 10,80	40	53	100	12,0	193,00
22 0404 1080 056	• 10,80	56	69	116	12,0	243,00
22 0404 1090 040	• 10,90	40	53	100	12,0	193,00
22 0404 1090 056	• 10,90	56	69	116	12,0	243,00
22 0404 1100 040	• 11,00	40	53	100	12,0	193,00
22 0404 1100 056	• 11,00	56	69	116	12,0	243,00
22 0404 1120 040	• 11,20	40	53	100	12,0	193,00
22 0404 1120 056	• 11,20	56	69	116	12,0	243,00
22 0404 1150 040	• 11,50	40	53	100	12,0	193,00
22 0404 1150 056	• 11,50	56	69	116	12,0	243,00
22 0404 1180 040	• 11,80	40	53	100	12,0	193,00
22 0404 1180 056	• 11,80	56	69	116	12,0	243,00
22 0404 1200 040	• 12,00	40	53	100	12,0	193,00
22 0404 1200 056	• 12,00	56	69	116	12,0	243,00



180° Spitzenwinkel  
180° Point angle

22 0404

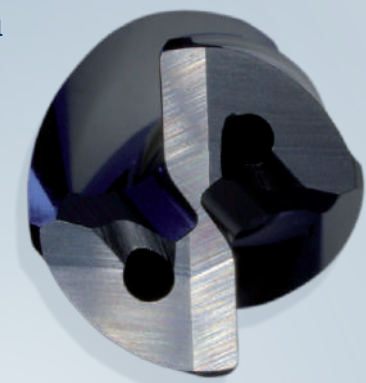
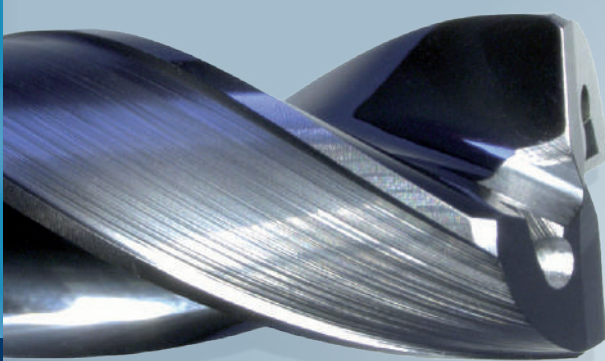

Vollhartmetall-Hochleistungsbohrer, DIN 6535 HEK  
Solid carbide high performance twist drill, DIN 6535 HEK

22 0405

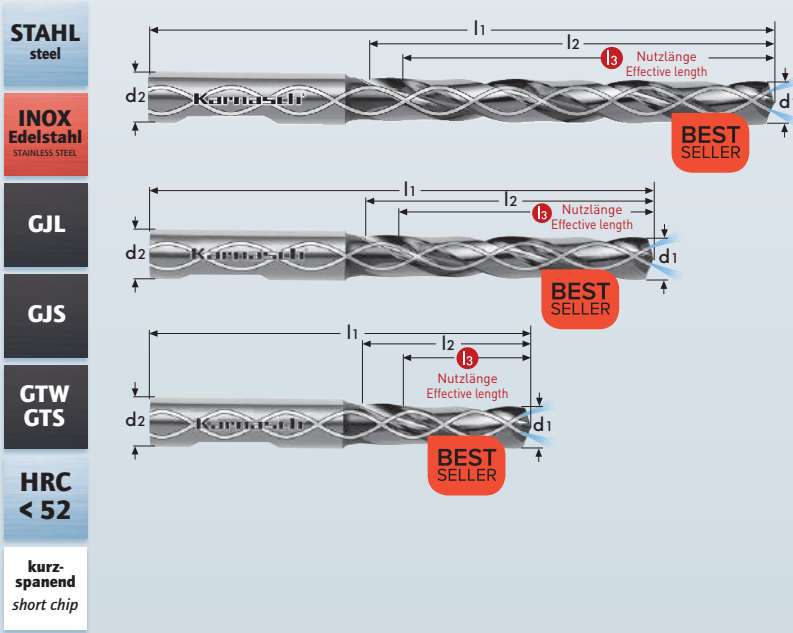

<b>MICRO GRAIN</b>	<b>DIN 6537</b>
<b>N</b>	<b>DIN 6535 Form HEK</b>
	<b>HSC HPC</b>
	<b>DVC-X2</b>

Schnittdaten Cutting data	Zeichnungen Drawings
1252	DXF/STEP

Bestseller - Preis reduziert - Bestseller - Price reduced

Art.	d1 m7	l3	l2	l1	d2 h6	€
22 0405 0300 014	• 3,0	14	20	62	6,0	61,00
22 0405 0300 023	• 3,0	23	28	66	6,0	64,00
22 0405 0300 029	• 3,0	29	34	72	6,0	85,00
22 0405 0310 014	• 3,1	14	20	62	6,0	61,00
22 0405 0310 023	• 3,1	23	28	66	6,0	64,00
22 0405 0310 029	• 3,1	29	34	72	6,0	85,00
22 0405 0320 014	• 3,2	14	20	62	6,0	61,00
22 0405 0320 023	• 3,2	23	28	66	6,0	64,00
22 0405 0320 029	• 3,2	29	34	72	6,0	85,00
22 0405 0330 014	• 3,3	14	20	62	6,0	61,00
22 0405 0330 023	• 3,3	23	28	66	6,0	64,00
22 0405 0330 029	• 3,3	29	34	72	6,0	85,00
22 0405 0340 014	• 3,4	14	20	62	6,0	61,00
22 0405 0340 023	• 3,4	23	28	66	6,0	64,00
22 0405 0340 029	• 3,4	29	34	72	6,0	85,00
22 0405 0350 014	• 3,5	14	20	62	6,0	61,00
22 0405 0350 023	• 3,5	23	28	66	6,0	64,00
22 0405 0350 029	• 3,5	29	34	72	6,0	85,00
22 0405 0360 014	• 3,6	14	20	62	6,0	61,00
22 0405 0360 023	• 3,6	23	28	66	6,0	64,00
22 0405 0360 029	• 3,6	29	34	72	6,0	85,00
22 0405 0370 014	• 3,7	14	20	62	6,0	61,00
22 0405 0370 023	• 3,7	23	28	66	6,0	64,00
22 0405 0370 029	• 3,7	29	34	72	6,0	85,00
22 0405 0380 017	• 3,8	17	24	66	6,0	61,00
22 0405 0380 029	• 3,8	29	36	74	6,0	64,00
22 0405 0380 036	• 3,8	36	43	81	6,0	90,00
22 0405 0390 017	• 3,9	17	24	66	6,0	61,00
22 0405 0390 029	• 3,9	29	36	74	6,0	64,00
22 0405 0390 036	• 3,9	36	43	81	6,0	90,00
22 0405 0400 017	• 4,0	17	24	66	6,0	61,00
22 0405 0400 029	• 4,0	29	36	74	6,0	64,00
22 0405 0400 036	• 4,0	36	43	81	6,0	90,00
22 0405 0410 017	• 4,1	17	24	66	6,0	61,00
22 0405 0410 029	• 4,1	29	36	74	6,0	64,00
22 0405 0410 036	• 4,1	36	43	81	6,0	90,00

Art.	d1 m7	l3	l2	l1	d2 h6	€
22 0405 0420 017	• 4,2	17	24	66	6,0	61,00
22 0405 0420 029	• 4,2	29	36	74	6,0	64,00
22 0405 0420 036	• 4,2	36	43	81	6,0	90,00
22 0405 0430 017	• 4,3	17	24	66	6,0	61,00
22 0405 0430 029	• 4,3	29	36	74	6,0	64,00
22 0405 0430 036	• 4,3	36	43	81	6,0	90,00
22 0405 0440 017	• 4,4	17	24	66	6,0	61,00
22 0405 0440 029	• 4,4	29	36	74	6,0	64,00
22 0405 0440 036	• 4,4	36	43	81	6,0	90,00
22 0405 0450 017	• 4,5	17	24	66	6,0	61,00
22 0405 0450 029	• 4,5	29	36	74	6,0	64,00
22 0405 0450 036	• 4,5	36	43	81	6,0	90,00
22 0405 0460 017	• 4,6	17	24	66	6,0	61,00
22 0405 0460 029	• 4,6	29	36	74	6,0	64,00
22 0405 0460 036	• 4,6	36	43	81	6,0	90,00
22 0405 0470 017	• 4,7	17	24	66	6,0	61,00
22 0405 0470 029	• 4,7	29	36	74	6,0	64,00
22 0405 0470 036	• 4,7	36	43	81	6,0	90,00
22 0405 0480 020	• 4,8	20	28	66	6,0	61,00
22 0405 0480 035	• 4,8	35	44	82	6,0	64,00
22 0405 0480 048	• 4,8	48	57	95	6,0	97,00
22 0405 0490 020	• 4,9	20	28	66	6,0	61,00
22 0405 0490 035	• 4,9	35	44	82	6,0	64,00
22 0405 0490 048	• 4,9	48	57	95	6,0	97,00
22 0405 0500 020	• 5,0	20	28	66	6,0	61,00
22 0405 0500 035	• 5,0	35	44	82	6,0	64,00
22 0405 0500 048	• 5,0	48	57	95	6,0	97,00
22 0405 0510 020	• 5,1	20	28	66	6,0	61,00
22 0405 0510 035	• 5,1	35	44	82	6,0	64,00
22 0405 0510 048	• 5,1	48	57	95	6,0	97,00
22 0405 0520 020	• 5,2	20	28	66	6,0	61,00
22 0405 0520 035	• 5,2	35	44	82	6,0	64,00
22 0405 0520 048	• 5,2	48	57	95	6,0	97,00
22 0405 0530 020	• 5,3	20	28	66	6,0	61,00
22 0405 0530 035	• 5,3	35	44	82	6,0	64,00
22 0405 0530 048	• 5,3	48	57	95	6,0	97,00

Alternative 22 0406 auf Seite 262-263  
Alternative 22 0406 on page 262-263



Index

22 0405

**STAHL**  
steel

**HRC**  
**< 52**

**INOX**  
Edelstahl  
STAINLESS STEEL

kurzspanend  
short chip

**GJL**

**GJS**

**GTW**  
GTS

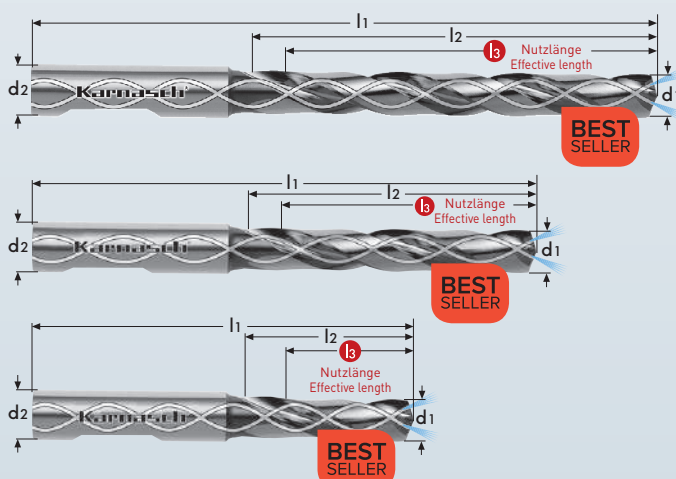

**MICRO**  
GRAIN

**DIN**  
6537

**N**

**DIN 6535**  
Form HEK



**HSC**  
**HPC**



**DVC-X2**



Bestseller - Preis reduziert · Bestseller - Price reduced

Art.	d1 m7	l3	l2	l1	d2 h6	€
22 0405 0540 020	• 5,4	20	28	66	6,0	61,00
22 0405 0540 035	• 5,4	35	44	82	6,0	64,00
22 0405 0540 048	• 5,4	48	57	95	6,0	97,00
22 0405 0550 020	• 5,5	20	28	66	6,0	61,00
22 0405 0550 035	• 5,5	35	44	82	6,0	64,00
22 0405 0550 048	• 5,5	48	57	95	6,0	97,00
22 0405 0560 020	• 5,6	20	28	66	6,0	61,00
22 0405 0560 035	• 5,6	35	44	82	6,0	64,00
22 0405 0560 048	• 5,6	48	57	95	6,0	97,00
22 0405 0570 020	• 5,7	20	28	66	6,0	61,00
22 0405 0570 035	• 5,7	35	44	82	6,0	64,00
22 0405 0570 048	• 5,7	48	57	95	6,0	97,00
22 0405 0580 020	• 5,8	20	28	66	6,0	61,00
22 0405 0580 035	• 5,8	35	44	82	6,0	64,00
22 0405 0580 048	• 5,8	48	57	95	6,0	97,00
22 0405 0590 020	• 5,9	20	28	66	6,0	61,00
22 0405 0590 035	• 5,9	35	44	82	6,0	64,00
22 0405 0590 048	• 5,9	48	57	95	6,0	97,00
22 0405 0600 020	• 6,0	20	28	66	6,0	61,00
22 0405 0600 035	• 6,0	35	44	82	6,0	64,00
22 0405 0600 048	• 6,0	48	57	95	6,0	97,00
22 0405 0610 024	• 6,1	24	34	79	8,0	69,00
22 0405 0610 043	• 6,1	43	53	91	8,0	72,00
22 0405 0610 064	• 6,1	64	76	114	8,0	128,00
22 0405 0620 024	• 6,2	24	34	79	8,0	69,00
22 0405 0620 043	• 6,2	43	53	91	8,0	72,00
22 0405 0620 064	• 6,2	64	76	114	8,0	128,00
22 0405 0630 024	• 6,3	24	34	79	8,0	69,00
22 0405 0630 043	• 6,3	43	53	91	8,0	72,00
22 0405 0630 064	• 6,3	64	76	114	8,0	128,00
22 0405 0640 024	• 6,4	24	34	79	8,0	69,00
22 0405 0640 043	• 6,4	43	53	91	8,0	72,00
22 0405 0640 064	• 6,4	64	76	114	8,0	128,00
22 0405 0650 024	• 6,5	24	34	79	8,0	69,00
22 0405 0650 043	• 6,5	43	53	91	8,0	72,00
22 0405 0650 064	• 6,5	64	76	114	8,0	128,00
22 0405 0660 024	• 6,6	24	34	79	8,0	69,00
22 0405 0660 043	• 6,6	43	53	91	8,0	72,00
22 0405 0660 064	• 6,6	64	76	114	8,0	128,00
22 0405 0670 024	• 6,7	24	34	79	8,0	69,00
22 0405 0670 043	• 6,7	43	53	91	8,0	72,00
22 0405 0670 064	• 6,7	64	76	114	8,0	128,00
22 0405 0680 024	• 6,8	24	34	79	8,0	69,00
22 0405 0680 043	• 6,8	43	53	91	8,0	72,00
22 0405 0680 064	• 6,8	64	76	114	8,0	128,00
22 0405 0690 024	• 6,9	24	34	79	8,0	69,00
22 0405 0690 043	• 6,9	43	53	91	8,0	72,00
22 0405 0690 064	• 6,9	64	76	114	8,0	128,00
22 0405 0700 024	• 7,0	24	34	79	8,0	69,00
22 0405 0700 043	• 7,0	43	53	91	8,0	72,00

Art.	d1 m7	l3	l2	l1	d2 h6	€
22 0405 0700 066	• 7,0	64	76	114	8,0	128,00
22 0405 0710 029	• 7,1	29	41	79	8,0	69,00
22 0405 0710 043	• 7,1	43	53	91	8,0	72,00
22 0405 0710 066	• 7,1	64	76	114	8,0	128,00
22 0405 0720 029	• 7,2	29	41	79	8,0	69,00
22 0405 0720 043	• 7,2	43	53	91	8,0	72,00
22 0405 0720 066	• 7,2	64	76	114	8,0	128,00
22 0405 0730 029	• 7,3	29	41	79	8,0	69,00
22 0405 0730 043	• 7,3	43	53	91	8,0	72,00
22 0405 0730 066	• 7,3	64	76	114	8,0	128,00
22 0405 0740 029	• 7,4	29	41	79	8,0	69,00
22 0405 0740 043	• 7,4	43	53	91	8,0	72,00
22 0405 0740 066	• 7,4	64	76	114	8,0	128,00
22 0405 0750 029	• 7,5	29	41	79	8,0	69,00
22 0405 0750 043	• 7,5	43	53	91	8,0	72,00
22 0405 0750 066	• 7,5	64	76	114	8,0	128,00
22 0405 0760 029	• 7,6	29	41	79	8,0	69,00
22 0405 0760 043	• 7,6	43	53	91	8,0	72,00
22 0405 0760 066	• 7,6	64	76	114	8,0	128,00
22 0405 0770 029	• 7,7	29	41	79	8,0	69,00
22 0405 0770 043	• 7,7	43	53	91	8,0	72,00
22 0405 0770 066	• 7,7	64	76	114	8,0	128,00
22 0405 0780 029	• 7,8	29	41	79	8,0	69,00
22 0405 0780 043	• 7,8	43	53	91	8,0	72,00
22 0405 0780 066	• 7,8	64	76	114	8,0	128,00
22 0405 0790 029	• 7,9	29	41	79	8,0	69,00
22 0405 0790 043	• 7,9	43	53	91	8,0	72,00
22 0405 0790 066	• 7,9	64	76	114	8,0	128,00
22 0405 0800 029	• 8,0	29	41	79	8,0	69,00
22 0405 0800 043	• 8,0	43	53	91	8,0	72,00
22 0405 0800 066	• 8,0	64	76	114	8,0	128,00
22 0405 0810 035	• 8,1	35	47	89	10,0	81,00
22 0405 0810 049	• 8,1	49	61	103	10,0	84,00
22 0405 0810 080	• 8,1	80	95	142	10,0	170,00
22 0405 0820 035	• 8,2	35	47	89	10,0	81,00
22 0405 0820 049	• 8,2	49	61	103	10,0	84,00
22 0405 0820 080	• 8,2	80	95	142	10,0	170,00
22 0405 0830 035	• 8,3	35	47	89	10,0	81,00
22 0405 0830 049	• 8,3	49	61	103	10,0	84,00
22 0405 0830 080	• 8,3	80	95	142	10,0	170,00
22 0405 0840 035	• 8,4	35	47	89	10,0	81,00
22 0405 0840 049	• 8,4	49	61	103	10,0	84,00
22 0405 0840 080	• 8,4	80	95	142	10,0	170,00
22 0405 0850 035	• 8,5	35	47	89	10,0	81,00
22 0405 0850 049	• 8,5	49	61	103	10,0	84,00
22 0405 0850 080	• 8,5	80	95	142	10,0	170,00
22 0405 0860 035	• 8,6	35	47	89	10,0	81,00
22 0405 0860 049	• 8,6	49	61	103	10,0	84,00
22 0405 0860 080	• 8,6	80	95	142	10,0	170,00
22 0405 0870 035	• 8,7	35	47	89	10,0	81,00

Alternative 22 0406 auf Seite 262-263  
Alternative 22 0406 on page 262-263

Art.	d1 m7	l3	l2	l1	d2 h6	€
22 0405 0870 049	• 8,7	49	61	103	10,0	84,00
22 0405 0870 080	• 8,7	80	95	142	10,0	170,00
22 0405 0880 035	• 8,8	35	47	89	10,0	81,00
22 0405 0880 049	• 8,8	49	61	103	10,0	84,00
22 0405 0880 080	• 8,8	80	95	142	10,0	170,00
22 0405 0890 035	• 8,9	35	47	89	10,0	81,00
22 0405 0890 049	• 8,9	49	61	103	10,0	84,00
22 0405 0890 080	• 8,9	80	95	142	10,0	170,00
22 0405 0900 035	• 9,0	35	47	89	10,0	81,00
22 0405 0900 049	• 9,0	49	61	103	10,0	84,00
22 0405 0900 080	• 9,0	80	95	142	10,0	170,00
22 0405 0910 035	• 9,1	35	47	89	10,0	81,00
22 0405 0910 049	• 9,1	49	61	103	10,0	84,00
22 0405 0910 080	• 9,1	80	95	142	10,0	170,00
22 0405 0920 035	• 9,2	35	47	89	10,0	81,00
22 0405 0920 049	• 9,2	49	61	103	10,0	84,00
22 0405 0920 080	• 9,2	80	95	142	10,0	170,00
22 0405 0930 035	• 9,3	35	47	89	10,0	81,00
22 0405 0930 049	• 9,3	49	61	103	10,0	84,00
22 0405 0930 080	• 9,3	80	95	142	10,0	170,00
22 0405 0940 035	• 9,4	35	47	89	10,0	81,00
22 0405 0940 049	• 9,4	49	61	103	10,0	84,00
22 0405 0940 080	• 9,4	80	95	142	10,0	170,00
22 0405 0950 035	• 9,5	35	47	89	10,0	81,00
22 0405 0950 049	• 9,5	49	61	103	10,0	84,00
22 0405 0950 080	• 9,5	80	95	142	10,0	170,00
22 0405 0960 035	• 9,6	35	47	89	10,0	81,00
22 0405 0960 049	• 9,6	49	61	103	10,0	84,00
22 0405 0960 080	• 9,6	80	95	142	10,0	170,00
22 0405 0970 035	• 9,7	35	47	89	10,0	81,00
22 0405 0970 049	• 9,7	49	61	103	10,0	84,00
22 0405 0970 080	• 9,7	80	95	142	10,0	170,00
22 0405 0980 035	• 9,8	35	47	89	10,0	81,00
22 0405 0980 049	• 9,8	49	61	103	10,0	84,00
22 0405 0980 080	• 9,8	80	95	142	10,0	170,00
22 0405 0990 035	• 9,9	35	47	89	10,0	81,00
22 0405 0990 049	• 9,9	49	61	103	10,0	84,00
22 0405 0990 080	• 9,9	80	95	142	10,0	170,00
22 0405 1000 035	• 10,0	35	47	89	10,0	81,00
22 0405 1000 049	• 10,0	49	61	103	10,0	84,00
22 0405 1000 080	• 10,0	80	95	142	10,0	170,00
22 0405 1010 040	• 10,1	40	55	102	12,0	114,00
22 0405 1010 056	• 10,1	56	71	118	12,0	119,00
22 0405 1010 096	• 10,1	96	114	162	12,0	236,00
22 0405 1020 040	• 10,2	40	55	102	12,0	114,00
22 0405 1020 056	• 10,2	56	71	118	12,0	119,00
22 0405 1020 096	• 10,2	96	114	162	12,0	236,00
22 0405 1030 040	• 10,3	40	55	102	12,0	114,00
22 0405 1030 056	• 10,3	56	71	118	12,0	119,00
22 0405 1030 096	• 10,3	96	114	162	12,0	236,00
22 0405 1040 040	• 10,4	40	55	102	12,0	114,00
22 0405 1040 056	• 10,4	56	71	118	12,0	119,00
22 0405 1040 096	• 10,4	96	114	162	12,0	236,00
22 0405 1050 040	• 10,5	40	55	102	12,0	114,00
22 0405 1050 056	• 10,5	56	71	118	12,0	119,00
22 0405 1050 096	• 10,5	96	114	162	12,0	236,00
22 0405 1060 040	• 10,6	40	55	102	12,0	114,00
22 0405 1060 056	• 10,6	56	71	118	12,0	119,00
22 0405 1060 096	• 10,6	96	114	162	12,0	236,00
22 0405 1060 142	• 10,6	142	156	204	12,0	178,20
22 0405 1070 040	• 10,7	40	55	102	12,0	114,00
22 0405 1070 056	• 10,7	56	71	118	12,0	119,00
22 0405 1070 096	• 10,7	96	114	162	12,0	236,00
22 0405 1070 142	• 10,7	142	156	204	12,0	178,20
22 0405 1080 040	• 10,8	40	55	102	12,0	114,00
22 0405 1080 056	• 10,8	56	71	118	12,0	119,00
22 0405 1080 096	• 10,8	96	114	162	12,0	236,00
22 0405 1090 040	• 10,9	40	55	102	12,0	114,00
22 0405 1090 056	• 10,9	56	71	118	12,0	119,00
22 0405 1090 096	• 10,9	96	114	162	12,0	236,00
22 0405 1090 142	• 10,9	142	156	204	12,0	178,20
22 0405 1100 040	• 11,0	40	55	102	12,0	114,00
22 0405 1100 056	• 11,0	56	71	118	12,0	119,00
22 0405 1100 096	• 11,0	96	114	162	12,0	236,00
22 0405 1110 040	• 11,1	40	55	102	12,0	114,00
22 0405 1110 056	• 11,1	56	71	118	12,0	119,00
22 0405 1110 096	• 11,1	96	114	162	12,0	236,00
22 0405 1120 040	• 11,2	40	55	102	12,0	114,00
22 0405 1120 056	• 11,2	56	71	118	12,0	119,00
22 0405 1120 096	• 11,2	96	114	162	12,0	236,00
22 0405 1130 040	• 11,3	40	55	102	12,0	114,00

Art.	d1 m7	l3	l2	l1	d2 h6	€
22 0405 1130 056	• 11,3	56	71	118	12,0	119,00
22 0405 1130 096	• 11,3	96	114	162	12,0	236,00
22 0405 1130 142	• 11,3	142	156	204	12,0	178,20
22 0405 1140 040	• 11,4	40	55	102	12,0	114,00
22 0405 1140 056	• 11,4	56	71	118	12,0	119,00
22 0405 1140 096	• 11,4	96	114	162	12,0	236,00
22 0405 1140 142	• 11,4	142	156	204	12,0	178,20
22 0405 1150 040	• 11,5	40	55	102	12,0	114,00
22 0405 1150 056	• 11,5	56	71	118	12,0	119,00
22 0405 1150 096	• 11,5	96	114	162	12,0	236,00
22 0405 1160 040	• 11,6	40	55	102	12,0	114,00
22 0405 1160 056	• 11,6	56	71	118	12,0	119,00
22 0405 1160 096	• 11,6	96	114	162	12,0	236,00
22 0405 1170 040	• 11,7	40	55	102	12,0	114,00
22 0405 1170 056	• 11,7	56	71	118	12,0	119,00
22 0405 1170 096	• 11,7	96	114	162	12,0	236,00
22 0405 1170 142	• 11,7	142	156	204	12,0	198,00
22 0405 1180 040	• 11,8	40	55	102	12,0	114,00
22 0405 1180 056	• 11,8	56	71	118	12,0	119,00
22 0405 1180 096	• 11,8	96	114	162	12,0	236,00
22 0405 1190 040	• 11,9	40	55	102	12,0	114,00
22 0405 1190 056	• 11,9	56	71	118	12,0	119,00
22 0405 1190 096	• 11,9	96	114	162	12,0	236,00
22 0405 1190 142	• 11,9	142	156	204	12,0	178,20
22 0405 1200 040	• 12,0	40	55	102	12,0	114,00
22 0405 1200 056	• 12,0	56	71	118	12,0	119,00
22 0405 1200 096	• 12,0	96	114	162	12,0	236,00
22 0405 1230 060	• 12,3	60	77	124	14,0	158,00
22 0405 1240 060	• 12,4	60	77	124	14,0	158,00
22 0405 1250 043	• 12,5	43	60	107	14,0	151,00
22 0405 1250 060	• 12,5	60	77	124	14,0	158,00
22 0405 1250 112	• 12,5	112	133	178	14,0	335,00
22 0405 1270 060	• 12,7	60	77	124	14,0	158,00
22 0405 1280 060	• 12,8	60	77	124	14,0	158,00
22 0405 1280 112	• 12,8	112	133	178	14,0	335,00
22 0405 1300 043	• 13,0	43	60	107	14,0	151,00
22 0405 1300 060	• 13,0	60	77	124	14,0	158,00
22 0405 1300 112	• 13,0	112	133	178	14,0	335,00
22 0405 1350 043	• 13,5	43	60	107	14,0	151,00
22 0405 1350 060	• 13,5	60	77	124	14,0	158,00
22 0405 1350 112	• 13,5	112	133	178	14,0	335,00
22 0405 1380 043	• 13,8	43	60	107	14,0	151,00
22 0405 1380 060	• 13,8	60	77	124	14,0	158,00
22 0405 1380 112	• 13,8	112	133	178	14,0	335,00
22 0405 1400 043	• 14,0	43	60	107	14,0	151,00
22 0405 1400 060	• 14,0	60	77	124	14,0	158,00
22 0405 1400 112	• 14,0	112	133	178	14,0	335,00
22 0405 1450 045	• 14,5	45	65	115	16,0	214,00
22 0405 1450 063	• 14,5	63	83	133	16,0	211,00
22 0405 1500 045	• 15,0	45	65	115	16,0	214,00
22 0405 1500 063	• 15,0	63	83	133	16,0	211,00
22 0405 1500 128	• 15,0	128	152	203	16,0	439,00
22 0405 1550 045	• 15,5	45	65	115	16,0	214,00
22 0405 1550 063	• 15,5	63	83	133	16,0	211,00
22 0405 1550 128	• 15,5	128	152	203	16,0	439,00
22 0405 1580 128	• 15,8	128	152	203	16,0	439,00
22 0405 1600 045	• 16,0	45	65	115	16,0	214,00
22 0405 1600 063	• 16,0	63	83	133	16,0	211,00
22 0405 1650 051	• 16,5	51	73	123	18,0	298,00
22 0405 1650 071	• 16,5	71	93	143	18,0	324,00
22 0405 1680 051	• 16,8	51	73	123	18,0	298,00
22 0405 1680 071	• 16,8	71	93	143	18,0	324,00
22 0405 1700 051	• 17,0	51	73	123	18,0	298,00
22 0405 1700 071	• 17,0	71	93	143	18,0	324,00
22 0405 1750 051	• 17,5	51	73	123	18,0	298,00
22 0405 1750 071	• 17,5	71	93	143	18,0	324,00
22 0405 1780 071	• 17,8	71	93	143	18,0	324,00
22 0405 1800 051	• 18,0	51	73	123	18,0	298,00
22 0405 1800 071	• 18,0	71	93	143	18,0	324,00
22 0405 1850 055	• 18,5	55	79	131	20,0	368,00
22 0405 1850 077	• 18,5	77	101	153	20,0	409,00
22 0405 1850 160	• 18,5	160	190	243	20,0	

## 22 0406

Vollhartmetall-Hochleistungsbohrer, DIN 6535 HAK  
Solid carbide high performance twist drill, DIN 6535 HAK

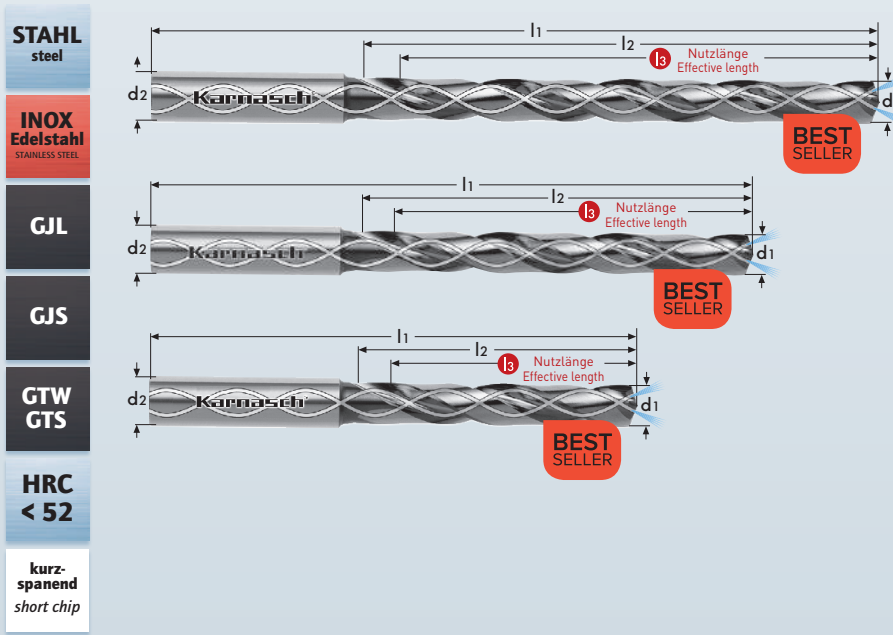

<b>MICRO GRAIN</b>	<b>DIN 6537</b>
<b>N</b>	<b>DIN 6535 Form HAK</b>
	<b>HSC HPC</b>
	<b>DVC-X2</b>

Schnittdaten Cutting data | Zeichnungen Drawings

1252 |

Bestseller - Preis reduziert · Bestseller - Price reduced

Art.	d1 m7	l3	l2	l1	d2 h6	€
22 0406 0300 023	• 3,0	23	28	66	6,0	64,00
22 0406 0300 029	• 3,0	29	34	72	6,0	85,00
22 0406 0300 048	• 3,0	48	54	92	6,0	105,00
22 0406 0310 023	• 3,1	23	28	66	6,0	64,00
22 0406 0310 029	• 3,1	29	34	72	6,0	85,00
22 0406 0310 048	• 3,1	48	54	92	6,0	106,00
22 0406 0320 023	• 3,2	23	28	66	6,0	64,00
22 0406 0320 029	• 3,2	29	34	72	6,0	85,00
22 0406 0320 048	• 3,2	48	54	92	6,0	106,00
22 0406 0330 023	• 3,3	23	28	66	6,0	64,00
22 0406 0330 029	• 3,3	29	34	72	6,0	85,00
22 0406 0330 048	• 3,3	48	54	92	6,0	106,00
22 0406 0340 023	• 3,4	23	28	66	6,0	64,00
22 0406 0340 029	• 3,4	29	34	72	6,0	85,00
22 0406 0340 048	• 3,4	48	54	92	6,0	106,00
22 0406 0350 023	• 3,5	23	28	66	6,0	64,00
22 0406 0350 029	• 3,5	29	34	72	6,0	85,00
22 0406 0350 048	• 3,5	48	54	92	6,0	106,00
22 0406 0360 023	• 3,6	23	28	66	6,0	64,00
22 0406 0360 029	• 3,6	29	34	72	6,0	85,00
22 0406 0360 048	• 3,6	48	54	92	6,0	106,00
22 0406 0365 023	• 3,65	23	28	66	6,0	64,00
22 0406 0370 023	• 3,7	23	28	66	6,0	64,00
22 0406 0370 029	• 3,7	29	34	72	6,0	85,00
22 0406 0370 048	• 3,7	48	54	92	6,0	106,00
22 0406 0380 029	• 3,8	29	36	74	6,0	64,00
22 0406 0380 036	• 3,8	36	43	81	6,0	90,00
22 0406 0380 058	• 3,8	58	64	102	6,0	106,00
22 0406 0390 029	• 3,9	29	36	74	6,0	64,00
22 0406 0390 036	• 3,9	36	43	81	6,0	90,00
22 0406 0390 058	• 3,9	58	64	102	6,0	106,00
22 0406 0400 029	• 4,0	29	36	74	6,0	64,00
22 0406 0400 036	• 4,0	36	43	81	6,0	90,00
22 0406 0400 058	• 4,0	58	64	102	6,0	106,00
22 0406 0410 029	• 4,1	29	36	74	6,0	64,00
22 0406 0410 036	• 4,1	36	43	81	6,0	90,00
22 0406 0410 058	• 4,1	58	64	102	6,0	106,00
22 0406 0420 029	• 4,2	29	36	74	6,0	64,00
22 0406 0420 036	• 4,2	36	43	81	6,0	90,00
22 0406 0420 058	• 4,2	58	64	102	6,0	106,00
22 0406 0430 029	• 4,3	29	36	74	6,0	64,00
22 0406 0430 036	• 4,3	36	43	81	6,0	90,00
22 0406 0430 058	• 4,3	58	64	102	6,0	106,00
22 0406 0440 029	• 4,4	29	36	74	6,0	64,00
22 0406 0440 036	• 4,4	36	43	81	6,0	90,00
22 0406 0440 058	• 4,4	58	64	102	6,0	106,00
22 0406 0450 029	• 4,5	29	36	74	6,0	64,00
22 0406 0450 036	• 4,5	36	43	81	6,0	90,00
22 0406 0450 058	• 4,5	58	64	102	6,0	106,00

Art.	d1 m7	l3	l2	l1	d2 h6	€
22 0406 0460 029	• 4,6	29	36	74	6,0	64,00
22 0406 0460 036	• 4,6	36	43	81	6,0	90,00
22 0406 0460 058	• 4,6	58	64	102	6,0	106,00
22 0406 0465 029	• 4,65	29	36	74	6,0	64,00
22 0406 0470 029	• 4,7	29	36	74	6,0	64,00
22 0406 0470 036	• 4,7	36	43	81	6,0	90,00
22 0406 0470 058	• 4,7	58	64	102	6,0	106,00
22 0406 0480 035	• 4,8	35	44	82	6,0	64,00
22 0406 0480 048	• 4,8	48	57	95	6,0	97,00
22 0406 0480 070	• 4,8	70	78	116	6,0	106,00
22 0406 0490 035	• 4,9	35	44	82	6,0	64,00
22 0406 0490 048	• 4,9	48	57	95	6,0	97,00
22 0406 0490 070	• 4,9	70	78	116	6,0	106,00
22 0406 0500 035	• 5,0	35	44	82	6,0	64,00
22 0406 0500 048	• 5,0	48	57	95	6,0	97,00
22 0406 0500 070	• 5,0	70	78	116	6,0	106,00
22 0406 0510 035	• 5,1	35	44	82	6,0	64,00
22 0406 0510 048	• 5,1	48	57	95	6,0	97,00
22 0406 0510 070	• 5,1	70	78	116	6,0	106,00
22 0406 0520 035	• 5,2	35	44	82	6,0	64,00
22 0406 0520 048	• 5,2	48	57	95	6,0	97,00
22 0406 0520 070	• 5,2	70	78	116	6,0	106,00
22 0406 0530 035	• 5,3	35	44	82	6,0	64,00
22 0406 0530 048	• 5,3	48	57	95	6,0	97,00
22 0406 0530 070	• 5,3	70	78	116	6,0	106,00
22 0406 0540 035	• 5,4	35	44	82	6,0	64,00
22 0406 0540 048	• 5,4	48	57	95	6,0	97,00
22 0406 0540 070	• 5,4	70	78	116	6,0	106,00
22 0406 0550 035	• 5,5	35	44	82	6,0	64,00
22 0406 0550 048	• 5,5	48	57	95	6,0	97,00
22 0406 0550 070	• 5,5	70	78	116	6,0	106,00
22 0406 0560 035	• 5,6	35	44	82	6,0	64,00
22 0406 0560 048	• 5,6	48	57	95	6,0	97,00
22 0406 0560 070	• 5,6	70	78	116	6,0	106,00
22 0406 0570 035	• 5,7	35	44	82	6,0	64,00
22 0406 0570 048	• 5,7	48	57	95	6,0	97,00
22 0406 0570 070	• 5,7	70	78	116	6,0	106,00
22 0406 0580 035	• 5,8	35	44	82	6,0	64,00
22 0406 0580 048	• 5,8	48	57	95	6,0	97,00
22 0406 0580 070	• 5,8	70	78	116	6,0	106,00
22 0406 0590 035	• 5,9	35	44	82	6,0	64,00
22 0406 0590 048	• 5,9	48	57	95	6,0	97,00
22 0406 0590 070	• 5,9	70	78	116	6,0	106,00
22 0406 0600 035	• 6,0	35	44	82	6,0	64,00
22 0406 0600 048	• 6,0	48	57	95	6,0	97,00
22 0406 0600 070	• 6,0	70	78	116	6,0	106,00



## 22 0409

Vollhartmetall-Hochleistungsbohrer  
Solid carbide high performance twist drill

<b>INOX</b> stainless steel < 900 N/mm <sup>2</sup> ferritic	<b>HASTELLOY</b>
<b>INOX</b> stainless steel > 900 N/mm <sup>2</sup> martensitic	<b>MONEL</b>
<b>INOX</b> stainless steel < 900 N/mm <sup>2</sup> austenitic	<b>NIMONIC</b>
<b>NI-ALLOYS</b> < 900 N/mm <sup>2</sup>	<b>Ampco</b>
<b>NI-CO ALLOYS</b> > 900 N/mm <sup>2</sup>	<b>NICKEL</b> < 500 N/mm <sup>2</sup>
<b>HARDOX</b>	<b>lang-spanend</b> long chip

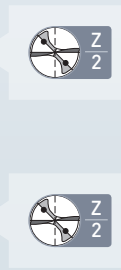
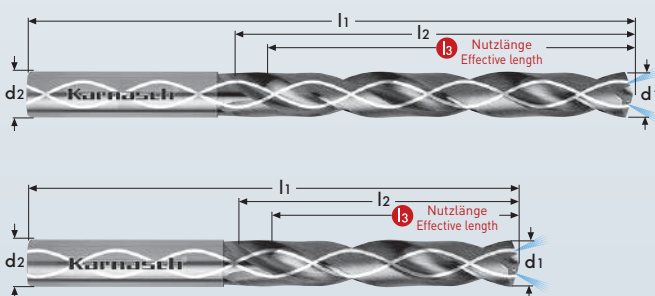

<b>MICRO GRAIN</b>	<b>DIN 6537</b>
<b>SPEZIAL</b> SPEZIAL	<b>DIN 6535</b> Form HAK
	<b>HSC</b> <b>HPC</b>
	<b>DVC-X1<sup>2</sup></b>

Schnittdaten  
Cutting data



Art.	d1 m7	l3	l2	l1	d2 h6	€
22 0409 0300 023	% 3,0	23	28	66	6,0	28,80
22 0409 0300 029	% 3,0	29	34	72	6,0	39,00
22 0409 0310 023	% 3,1	23	28	66	6,0	29,40
22 0409 0330 023	% 3,3	23	28	66	6,0	29,40
22 0409 0340 029	% 3,4	29	34	72	6,0	39,60
22 0409 0350 023	% 3,5	23	28	66	6,0	29,40
22 0409 0350 029	% 3,5	29	34	72	6,0	39,60
22 0409 0360 023	% 3,6	23	28	66	6,0	29,40
22 0409 0360 029	% 3,6	29	34	72	6,0	39,60
22 0409 0370 023	% 3,7	23	28	66	6,0	29,40
22 0409 0370 029	% 3,7	29	34	72	6,0	39,60
22 0409 0380 036	% 3,8	36	43	81	6,0	41,40
22 0409 0390 029	% 3,9	29	36	74	6,0	29,40
22 0409 0390 036	% 3,9	36	43	81	6,0	41,40
22 0409 0400 029	% 4,0	29	36	74	6,0	29,40
22 0409 0410 029	% 4,1	29	36	74	6,0	29,40
22 0409 0410 036	% 4,1	36	43	81	6,0	41,40
22 0409 0420 029	% 4,2	29	36	74	6,0	29,40
22 0409 0420 036	% 4,2	36	43	81	6,0	41,40
22 0409 0430 029	% 4,3	29	36	74	6,0	29,40
22 0409 0430 036	% 4,3	36	43	81	6,0	41,40
22 0409 0440 036	% 4,4	36	43	81	6,0	41,40
22 0409 0450 029	% 4,5	29	36	74	6,0	29,40
22 0409 0450 036	% 4,5	36	43	81	6,0	41,40
22 0409 0460 029	% 4,6	29	36	74	6,0	29,40
22 0409 0460 036	% 4,6	36	43	81	6,0	41,40
22 0409 0470 029	% 4,7	29	36	74	6,0	29,40
22 0409 0470 036	% 4,7	36	43	81	6,0	41,40
22 0409 0480 035	% 4,8	35	44	82	6,0	29,40
22 0409 0480 048	% 4,8	48	57	95	6,0	45,00
22 0409 0490 048	% 4,9	48	57	95	6,0	45,00
22 0409 0500 035	% 5,0	35	44	82	6,0	29,40
22 0409 0500 048	% 5,0	48	57	95	6,0	45,00
22 0409 0510 035	% 5,1	35	44	82	6,0	29,40
22 0409 0510 048	% 5,1	48	57	95	6,0	45,00
22 0409 0520 035	% 5,2	35	44	82	6,0	29,40
22 0409 0520 048	% 5,2	48	57	95	6,0	45,00
22 0409 0530 035	% 5,3	35	44	82	6,0	29,40

Art.	d1 m7	l3	l2	l1	d2 h6	€
22 0409 0530 048	% 5,3	48	57	95	6,0	45,00
22 0409 0540 035	% 5,4	35	44	82	6,0	29,40
22 0409 0540 048	% 5,4	48	57	95	6,0	45,00
22 0409 0550 035	% 5,5	35	44	82	6,0	29,40
22 0409 0550 048	% 5,5	48	57	95	6,0	45,00
22 0409 0560 035	% 5,6	35	44	82	6,0	29,40
22 0409 0560 048	% 5,6	48	57	95	6,0	45,00
22 0409 0570 035	% 5,7	35	44	82	6,0	29,40
22 0409 0570 048	% 5,7	48	57	95	6,0	45,00
22 0409 0580 035	% 5,8	35	44	82	6,0	29,40
22 0409 0580 048	% 5,8	48	57	95	6,0	45,00
22 0409 0590 035	% 5,9	35	44	82	6,0	29,40
22 0409 0590 048	% 5,9	48	57	95	6,0	45,00
22 0409 0600 035	% 6,0	35	44	82	6,0	29,40
22 0409 0600 048	% 6,0	48	57	95	6,0	45,00
22 0409 0610 043	% 6,1	43	53	91	8,0	33,60
22 0409 0610 064	% 6,1	64	76	114	8,0	58,80
22 0409 0620 043	% 6,2	43	53	91	8,0	33,60
22 0409 0620 064	% 6,2	64	76	114	8,0	58,80
22 0409 0630 043	% 6,3	43	53	91	8,0	33,60
22 0409 0630 064	% 6,3	64	76	114	8,0	58,80
22 0409 0640 043	% 6,4	43	53	91	8,0	33,60
22 0409 0640 064	% 6,4	64	76	114	8,0	58,80
22 0409 0650 043	% 6,5	43	53	91	8,0	33,60
22 0409 0650 064	% 6,5	64	76	114	8,0	58,80
22 0409 0660 064	% 6,6	64	76	114	8,0	58,80
22 0409 0670 043	% 6,7	43	53	91	8,0	33,60
22 0409 0670 064	% 6,7	64	76	114	8,0	58,80
22 0409 0680 043	% 6,8	43	53	91	8,0	33,60
22 0409 0680 064	% 6,8	64	76	114	8,0	58,80
22 0409 0690 043	% 6,9	43	53	91	8,0	33,60
22 0409 0690 064	% 6,9	64	76	114	8,0	58,80
22 0409 0700 043	% 7,0	43	53	91	8,0	33,60
22 0409 0700 064	% 7,0	64	76	114	8,0	58,80
22 0409 0710 043	% 7,1	43	53	91	8,0	33,60
22 0409 0710 064	% 7,1	64	76	114	8,0	58,80
22 0409 0720 043	% 7,2	43	53	91	8,0	33,60
22 0409 0720 064	% 7,2	64	76	114	8,0	58,80

Mindestbestellmenge für Zwischenabmessungen 5 Stück / Minimum order volume for intermediate dimensions 5 pieces ♦ auf Anfrage / on request

% Sonderpreis / Sale Artikel. Lieferbar solange Vorrat.  
Special price / sale article. While stocks last.

Art.	d1 m7	l3	l2	l1	d2 h6	€
22 0409 0730 043	% 7,3	43	53	91	8,0	33,60
22 0409 0730 064	% 7,3	64	76	114	8,0	58,80
22 0409 0740 043	% 7,4	43	53	91	8,0	33,60
22 0409 0740 064	% 7,4	64	76	114	8,0	58,80
22 0409 0750 043	% 7,5	43	53	91	8,0	33,60
22 0409 0750 064	% 7,5	64	76	114	8,0	58,80
22 0409 0760 043	% 7,6	43	53	91	8,0	33,60
22 0409 0760 064	% 7,6	64	76	114	8,0	58,80
22 0409 0770 043	% 7,7	43	53	91	8,0	33,60
22 0409 0770 064	% 7,7	64	76	114	8,0	58,80
22 0409 0780 043	% 7,8	43	53	91	8,0	33,60
22 0409 0780 064	% 7,8	64	76	114	8,0	58,80
22 0409 0790 043	% 7,9	43	53	91	8,0	33,60
22 0409 0790 064	% 7,9	64	76	114	8,0	58,80
22 0409 0800 043	% 8,0	43	53	91	8,0	33,60
22 0409 0800 064	% 8,0	64	76	114	8,0	58,80
22 0409 0810 049	% 8,1	49	61	103	10,0	38,40
22 0409 0810 080	% 8,1	80	95	142	10,0	78,60
22 0409 0820 049	% 8,2	49	61	103	10,0	38,40
22 0409 0820 080	% 8,2	80	95	142	10,0	78,60
22 0409 0830 049	% 8,3	49	61	103	10,0	38,40
22 0409 0830 080	% 8,3	80	95	142	10,0	78,60
22 0409 0840 049	% 8,4	49	61	103	10,0	38,40
22 0409 0840 080	% 8,4	80	95	142	10,0	78,60
22 0409 0850 080	% 8,5	80	95	142	10,0	78,60
22 0409 0870 049	% 8,7	49	61	103	10,0	38,40
22 0409 0870 080	% 8,7	80	95	142	10,0	78,60
22 0409 0880 049	% 8,8	49	61	103	10,0	38,40
22 0409 0880 080	% 8,8	80	95	142	10,0	78,60
22 0409 0890 049	% 8,9	49	61	103	10,0	38,40
22 0409 0890 080	% 8,9	80	95	142	10,0	78,60
22 0409 0900 049	% 9,0	49	61	103	10,0	38,40
22 0409 0900 080	% 9,0	80	95	142	10,0	78,60
22 0409 0910 049	% 9,1	49	61	103	10,0	38,40
22 0409 0910 080	% 9,1	80	95	142	10,0	78,60
22 0409 0920 049	% 9,2	49	61	103	10,0	38,40
22 0409 0930 049	% 9,3	49	61	103	10,0	38,40
22 0409 0930 080	% 9,3	80	95	142	10,0	78,60
22 0409 0940 049	% 9,4	49	61	103	10,0	38,40
22 0409 0940 080	% 9,4	80	95	142	10,0	78,60
22 0409 0950 049	% 9,5	49	61	103	10,0	38,40
22 0409 0960 049	% 9,6	49	61	103	10,0	38,40
22 0409 0960 080	% 9,6	80	95	142	10,0	78,60
22 0409 0970 049	% 9,7	49	61	103	10,0	38,40
22 0409 0970 080	% 9,7	80	95	142	10,0	78,60
22 0409 0980 049	% 9,8	49	61	103	10,0	38,40
22 0409 0980 080	% 9,8	80	95	142	10,0	78,60
22 0409 0990 049	% 9,9	49	61	103	10,0	38,40
22 0409 0990 080	% 9,9	80	95	142	10,0	78,60
22 0409 1000 049	% 10,0	49	61	103	10,0	38,40
22 0409 1000 080	% 10,0	80	95	142	10,0	79,09
22 0409 1010 056	% 10,1	56	71	118	12,0	54,60
22 0409 1010 096	% 10,1	96	114	162	12,0	106,80
22 0409 1020 056	% 10,2	56	71	118	12,0	54,60
22 0409 1020 096	% 10,2	96	114	162	12,0	106,80
22 0409 1030 056	% 10,3	56	71	118	12,0	54,60
22 0409 1030 096	% 10,3	96	114	162	12,0	106,80
22 0409 1040 056	% 10,4	56	71	118	12,0	54,60
22 0409 1040 096	% 10,4	96	114	162	12,0	106,80
22 0409 1050 056	% 10,5	56	71	118	12,0	54,60
22 0409 1050 096	% 10,5	96	114	162	12,0	106,80
22 0409 1060 056	% 10,6	56	71	118	12,0	54,60
22 0409 1060 096	% 10,6	96	114	162	12,0	106,80
22 0409 1070 056	% 10,7	56	71	118	12,0	54,60
22 0409 1070 096	% 10,7	96	114	162	12,0	106,80
22 0409 1080 056	% 10,8	56	71	118	12,0	54,60
22 0409 1080 096	% 10,8	96	114	162	12,0	106,80
22 0409 1090 056	% 10,9	56	71	118	12,0	54,60
22 0409 1090 096	% 10,9	96	114	162	12,0	106,80
22 0409 1100 056	% 11,0	56	71	118	12,0	54,60
22 0409 1100 096	% 11,0	96	114	162	12,0	106,80
22 0409 1110 056	% 11,1	56	71	118	12,0	54,60
22 0409 1110 096	% 11,1	96	114	162	12,0	106,80
22 0409 1120 056	% 11,2	56	71	118	12,0	54,60
22 0409 1120 096	% 11,2	96	114	162	12,0	106,80
22 0409 1130 056	% 11,3	56	71	118	12,0	54,60
22 0409 1130 096	% 11,3	96	114	162	12,0	106,80
22 0409 1140 056	% 11,4	56	71	118	12,0	54,60

Art.	d1 m7	l3	l2	l1	d2 h6	€
22 0409 1140 096	% 11,4	96	114	162	12,0	106,80
22 0409 1150 056	% 11,5	56	71	118	12,0	54,60
22 0409 1150 096	% 11,5	96	114	162	12,0	106,80
22 0409 1160 056	% 11,6	56	71	118	12,0	54,60
22 0409 1160 096	% 11,6	96	114	162	12,0	106,80
22 0409 1170 056	% 11,7	56	71	118	12,0	54,60
22 0409 1170 096	% 11,7	96	114	162	12,0	106,80
22 0409 1180 056	% 11,8	56	71	118	12,0	54,60
22 0409 1180 096	% 11,8	96	114	162	12,0	106,80
22 0409 1190 056	% 11,9	56	71	118	12,0	54,60
22 0409 1190 096	% 11,9	96	114	162	12,0	106,80
22 0409 1200 056	% 12,0	56	71	118	12,0	54,60
22 0409 1200 096	% 12,0	96	114	162	12,0	106,80
22 0409 1250 060	% 12,5	60	77	124	14,0	73,20
22 0409 1250 112	% 12,5	112	133	178	14,0	152,40
22 0409 1280 060	% 12,8	60	77	124	14,0	73,20
22 0409 1280 112	% 12,8	112	133	178	14,0	152,40
22 0409 1300 060	% 13,0	60	77	124	14,0	73,20
22 0409 1300 112	% 13,0	112	133	178	14,0	152,40
22 0409 1350 060	% 13,5	60	77	124	14,0	73,20
22 0409 1350 112	% 13,5	112	133	178	14,0	152,40
22 0409 1380 060	% 13,8	60	77	124	14,0	73,20
22 0409 1380 112	% 13,8	112	133	178	14,0	152,40
22 0409 1400 060	% 14,0	60	77	124	14,0	73,20
22 0409 1400 112	% 14,0	112	133	178	14,0	152,40
22 0409 1450 063	% 14,5	63	83	133	16,0	97,80
22 0409 1450 128	% 14,5	128	152	203	16,0	200,40
22 0409 1480 063	% 14,8	63	83	133	16,0	97,80
22 0409 1480 128	% 14,8	128	152	203	16,0	200,40
22 0409 1500 063	% 15,0	63	83	133	16,0	97,80
22 0409 1500 128	% 15,0	128	152	203	16,0	200,40
22 0409 1550 128	% 15,5	128	152	203	16,0	200,40
22 0409 1600 063	% 16,0	63	83	133	16,0	97,80
22 0409 1600 128	% 16,0	128	152	203	16,0	200,40

% Sonderpreis / Sale Artikel. Lieferbar solange Vorrat.  
Special price / sale article. While stocks last.





22 0410

VHM-Hochleistungsbohrer mit Innenkühlung für INCONEL  
Solid carbide high performance twist drill with interior cooling for INCONEL

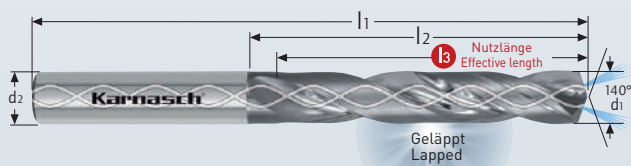

<b>MICRO GRAIN</b>	<b>DIN 6537 5xD</b>
<b>SPEZIAL SPECIAL</b>	<b>DIN 6535 Form HAK</b>
	<b>HSC HPC</b>
	<b>GELÄPFT LAPPED</b>

### Empfohlene Schnittdaten / Recommended cutting data

Werkstoffgruppe Material group	Werkstoff Material	Festigkeit Closeness	Schnittgeschwindigkeit Cutting speed Vc m/min	Vorschub pro Umdrehung Feed per revolution mm		
				Ø3 - Ø5	Ø5 - Ø8	Ø8 - Ø12
5.1 5.2 5.3	Nickel 100% Nickel-Legierung / Nickel alloy Nickel-Legierung / Nickel alloy	<900 N/mm <sup>2</sup> >900 N/mm <sup>2</sup>	25-35	0,04 - 0,09	0,06 - 0,16	0,13 - 0,22

Schnittdaten  
Cutting data

Zeichnungen  
Drawings

266	DXF/STEP

Art.	d1 h7	l3	l2	l1	d2 h6	€
22 0410 0300 023	• 3,0	23	28	66	6	123,00
22 0410 0320 023	• 3,2	23	28	66	6	123,00
22 0410 0330 023	• 3,3	23	28	66	6	123,00
22 0410 0340 023	• 3,4	23	28	66	6	123,00
22 0410 0350 023	• 3,5	23	28	66	6	123,00
22 0410 0370 023	• 3,7	23	28	66	6	123,00
22 0410 0380 029	• 3,8	29	36	74	6	123,00
22 0410 0390 029	• 3,9	29	36	74	6	123,00
22 0410 0400 029	• 4,0	29	36	74	6	123,00
22 0410 0420 029	• 4,2	29	36	74	6	123,00
22 0410 0430 029	• 4,3	29	36	74	6	123,00
22 0410 0450 029	• 4,5	29	36	74	6	123,00
22 0410 0465 029	• 4,65	29	36	74	6	123,00
22 0410 0480 035	• 4,8	35	44	82	6	123,00
22 0410 0500 035	• 5,0	35	44	82	6	123,00
22 0410 0510 035	• 5,1	35	44	82	6	123,00
22 0410 0520 035	• 5,2	35	44	82	6	123,00
22 0410 0530 035	• 5,3	35	44	82	6	123,00
22 0410 0540 035	• 5,4	35	44	82	6	123,00
22 0410 0550 035	• 5,5	35	44	82	6	123,00
22 0410 0555 035	• 5,55	35	44	82	6	123,00
22 0410 0560 035	• 5,6	35	44	82	6	123,00
22 0410 0570 035	• 5,7	35	44	82	6	123,00
22 0410 0580 035	• 5,8	35	44	82	6	123,00
22 0410 0600 035	• 6,0	35	44	82	6	123,00
22 0410 0610 043	• 6,1	43	53	91	8	134,00
22 0410 0620 043	• 6,2	43	53	91	8	134,00
22 0410 0630 043	• 6,3	43	53	91	8	134,00
22 0410 0640 043	• 6,4	43	53	91	8	134,00
22 0410 0650 043	• 6,5	43	53	91	8	134,00
22 0410 0660 043	• 6,6	43	53	91	8	134,00
22 0410 0670 043	• 6,7	43	53	91	8	134,00
22 0410 0680 043	• 6,8	43	53	91	8	134,00
22 0410 0690 043	• 6,9	43	53	91	8	134,00
22 0410 0700 043	• 7,0	43	53	91	8	134,00
22 0410 0710 043	• 7,1	43	53	91	8	134,00
22 0410 0720 043	• 7,2	43	53	91	8	134,00
22 0410 0730 043	• 7,3	43	53	91	8	134,00

Art.	d1 h7	l3	l2	l1	d2 h6	€
22 0410 0740 043	• 7,4	43	53	91	8	134,00
22 0410 0750 043	• 7,5	43	53	91	8	134,00
22 0410 0760 043	• 7,6	43	53	91	8	134,00
22 0410 0780 043	• 7,8	43	53	91	8	134,00
22 0410 0790 043	• 7,9	43	53	91	8	134,00
22 0410 0800 043	• 8,0	43	53	91	8	134,00
22 0410 0810 049	• 8,1	49	61	103	10	203,00
22 0410 0820 049	• 8,2	49	61	103	10	203,00
22 0410 0830 049	• 8,3	49	61	103	10	203,00
22 0410 0840 049	• 8,4	49	61	103	10	203,00
22 0410 0850 049	• 8,5	49	61	103	10	203,00
22 0410 0860 049	• 8,6	49	61	103	10	203,00
22 0410 0870 049	• 8,7	49	61	103	10	203,00
22 0410 0880 049	• 8,8	49	61	103	10	203,00
22 0410 0890 049	• 8,9	49	61	103	10	203,00
22 0410 0900 049	• 9,0	49	61	103	10	203,00
22 0410 0910 049	• 9,1	49	61	103	10	203,00
22 0410 0920 049	• 9,2	49	61	103	10	203,00
22 0410 0930 049	• 9,3	49	61	103	10	203,00
22 0410 0950 049	• 9,5	49	61	103	10	203,00
22 0410 0960 049	• 9,6	49	61	103	10	203,00
22 0410 0970 049	• 9,7	49	61	103	10	203,00
22 0410 0980 049	• 9,8	49	61	103	10	203,00
22 0410 1000 049	• 10,0	49	61	103	10	203,00
22 0410 1010 056	• 10,1	56	69	116	12	276,00
22 0410 1020 056	• 10,2	56	69	116	12	276,00
22 0410 1030 056	• 10,3	56	69	116	12	276,00
22 0410 1050 056	• 10,5	56	69	116	12	276,00
22 0410 1060 056	• 10,6	56	69	116	12	276,00
22 0410 1070 056	• 10,7	56	69	116	12	276,00
22 0410 1080 056	• 10,8	56	69	116	12	276,00
22 0410 1090 056	• 10,9	56	69	116	12	276,00
22 0410 1100 056	• 11,0	56	69	116	12	276,00
22 0410 1120 056	• 11,2	56	69	116	12	276,00
22 0410 1150 056	• 11,5	56	69	116	12	276,00
22 0410 1180 056	• 11,8	56	69	116	12	276,00
22 0410 1200 056	• 12,0	56	69	116	12	276,00

VHM-Hochleistungsbohrer mit Innenkühlung für **TITAN**  
 Solid carbide high performance twist drill with interior cooling for **TITANIUM**

22 0412

- TITAN titanium
- TITAN titanium < 1200 N/mm<sup>2</sup>
- TITAN GRADE 1 TITANIUM GRADE 1
- TITAN GRADE 2 TITANIUM GRADE 2
- TITAN GRADE 3 TITANIUM GRADE 3
- TITAN GRADE 4 TITANIUM GRADE 4
- TITAN GRADE 5 TITANIUM GRADE 5
- TITAN GRADE 12 TITANIUM GRADE 12

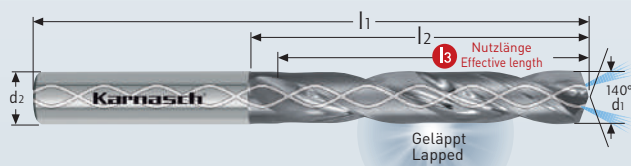

MICRO GRAIN	DIN 6537 5xD
SPEZIAL SPECIAL	DIN 6535 Form HAK
	HSC HPC
	GELÄPPT LAPPED

Empfohlene Schnittdaten / Recommended cutting data

Werkstoffgruppe Material group	Werkstoff Material	Festigkeit Closeness	Schnitt- geschwindigkeit Cutting speed Vc m/min	Vorschub pro Umdrehung Feed per revolution mm		
				Ø3 - Ø5	Ø5 - Ø8	Ø8 - Ø12
4.1 4.2 4.3	Reintitan / Pure Titanium 3.7105-3.7115-3.7124 3.7154-3.7164-3.7124	<900 N/mm <sup>2</sup> >900 N/mm <sup>2</sup>	30-45	0,10 - 0,17	0,14 - 0,26	0,20 - 0,40

Schnittdaten  
Cutting data

Zeichnungen  
Drawings

267

DXF/STEP

Art.	d1 h7	l3	l2	l1	d2 h6	€
22 0412 0300 023	• 3,0	23	28	66	6	123,00
22 0412 0320 023	• 3,2	23	28	66	6	123,00
22 0412 0330 023	• 3,3	23	28	66	6	123,00
22 0412 0340 023	• 3,4	23	28	66	6	123,00
22 0412 0350 023	• 3,5	23	28	66	6	123,00
22 0412 0370 023	• 3,7	23	28	66	6	123,00
22 0412 0380 029	• 3,8	29	36	74	6	123,00
22 0412 0390 029	• 3,9	29	36	74	6	123,00
22 0412 0400 029	• 4,0	29	36	74	6	123,00
22 0412 0420 029	• 4,2	29	36	74	6	123,00
22 0412 0430 029	• 4,3	29	36	74	6	123,00
22 0412 0450 029	• 4,5	29	36	74	6	123,00
22 0412 0465 029	• 4,65	29	36	74	6	123,00
22 0412 0480 035	• 4,8	35	44	82	6	123,00
22 0412 0500 035	• 5,0	35	44	82	6	123,00
22 0412 0510 035	• 5,1	35	44	82	6	123,00
22 0412 0520 035	• 5,2	35	44	82	6	123,00
22 0412 0530 035	• 5,3	35	44	82	6	123,00
22 0412 0540 035	• 5,4	35	44	82	6	123,00
22 0412 0550 035	• 5,5	35	44	82	6	123,00
22 0412 0555 035	• 5,55	35	44	82	6	123,00
22 0412 0560 035	• 5,6	35	44	82	6	123,00
22 0412 0570 035	• 5,7	35	44	82	6	123,00
22 0412 0580 035	• 5,8	35	44	82	6	123,00
22 0412 0600 035	• 6,0	35	44	82	6	123,00
22 0412 0610 043	• 6,1	43	53	91	8	134,00
22 0412 0620 043	• 6,2	43	53	91	8	134,00
22 0412 0630 043	• 6,3	43	53	91	8	134,00
22 0412 0640 043	• 6,4	43	53	91	8	134,00
22 0412 0650 043	• 6,5	43	53	91	8	134,00
22 0412 0660 043	• 6,6	43	53	91	8	134,00
22 0412 0670 043	• 6,7	43	53	91	8	134,00
22 0412 0680 043	• 6,8	43	53	91	8	134,00
22 0412 0690 043	• 6,9	43	53	91	8	134,00
22 0412 0700 043	• 7,0	43	53	91	8	134,00
22 0412 0710 043	• 7,1	43	53	91	8	134,00
22 0412 0720 043	• 7,2	43	53	91	8	134,00
22 0412 0730 043	• 7,3	43	53	91	8	134,00

Art.	d1 h7	l3	l2	l1	d2 h6	€
22 0412 0740 043	• 7,4	43	53	91	8	134,00
22 0412 0750 043	• 7,5	43	53	91	8	134,00
22 0412 0760 043	• 7,6	43	53	91	8	134,00
22 0412 0780 043	• 7,8	43	53	91	8	134,00
22 0412 0790 043	• 7,9	43	53	91	8	134,00
22 0412 0800 043	• 8,0	43	53	91	8	134,00
22 0412 0810 049	• 8,1	49	61	103	10	203,00
22 0412 0820 049	• 8,2	49	61	103	10	203,00
22 0412 0830 049	• 8,3	49	61	103	10	203,00
22 0412 0840 049	• 8,4	49	61	103	10	203,00
22 0412 0850 049	• 8,5	49	61	103	10	203,00
22 0412 0860 049	• 8,6	49	61	103	10	203,00
22 0412 0870 049	• 8,7	49	61	103	10	203,00
22 0412 0880 049	• 8,8	49	61	103	10	203,00
22 0412 0890 049	• 8,9	49	61	103	10	203,00
22 0412 0900 049	• 9,0	49	61	103	10	203,00
22 0412 0910 049	• 9,1	49	61	103	10	203,00
22 0412 0920 049	• 9,2	49	61	103	10	203,00
22 0412 0930 049	• 9,3	49	61	103	10	203,00
22 0412 0950 049	• 9,5	49	61	103	10	203,00
22 0412 0960 049	• 9,6	49	61	103	10	203,00
22 0412 0970 049	• 9,7	49	61	103	10	203,00
22 0412 0980 049	• 9,8	49	61	103	10	203,00
22 0412 1000 049	• 10,0	49	61	103	10	203,00
22 0412 1010 056	• 10,1	56	69	116	12	276,00
22 0412 1020 056	• 10,2	56	69	116	12	276,00
22 0412 1030 056	• 10,3	56	69	116	12	276,00
22 0412 1050 056	• 10,5	56	69	116	12	276,00
22 0412 1060 056	• 10,6	56	69	116	12	276,00
22 0412 1070 056	• 10,7	56	69	116	12	276,00
22 0412 1080 056	• 10,8	56	69	116	12	276,00
22 0412 1090 056	• 10,9	56	69	116	12	276,00
22 0412 1100 056	• 11,0	56	69	116	12	276,00
22 0412 1120 056	• 11,2	56	69	116	12	276,00
22 0412 1150 056	• 11,5	56	69	116	12	276,00
22 0412 1180 056	• 11,8	56	69	116	12	276,00
22 0412 1200 056	• 12,0	56	69	116	12	276,00

- 1
- 2
- 3
- 4
- 5
- 6
- 7
- 8
- 9

22 0419

IQ-DRILL 4-Fasen Bohrer für H7- Bohrung 5xD und 8xD mit/ohne Innenkühlung. Wir optimieren Ihre Fertigung. IQ-DRILL 4-chamfer 5xD and 8xD with/without interior cooling supply. We optimize your production.

22 0424

22 0425

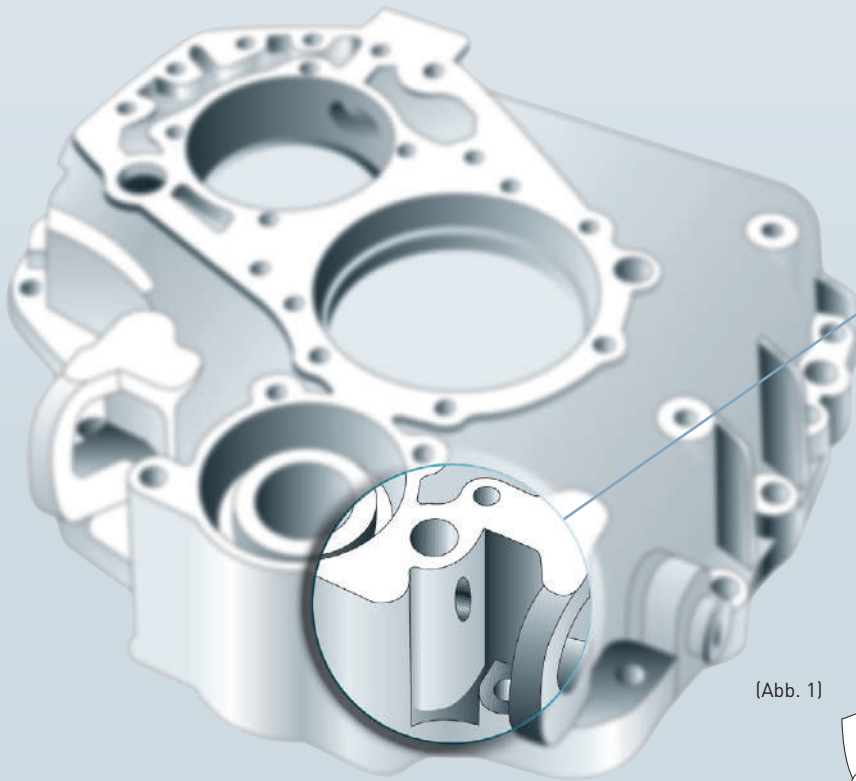

(Abb. 3)

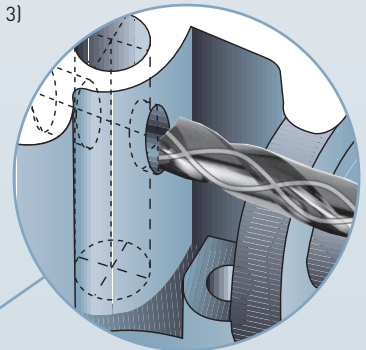

(Abb. 2)

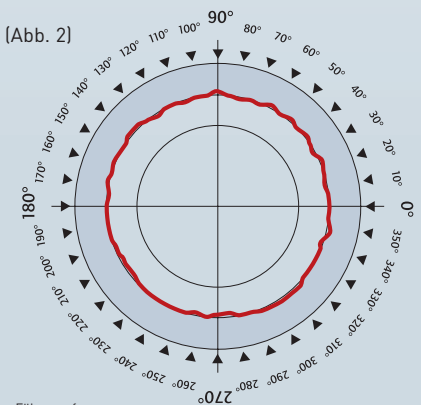

(Abb. 1)

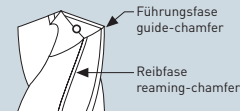

1 Diese Neuentwicklung aus unserem Hause erfüllt höchste Anforderungen an die Bohrungsqualität. Auf Reiboperationen kann in vielen Fällen verzichtet werden.

This new development from Karnasch meets highest demands on drill quality. Reaming after drilling is often not necessary any more.

2 4 Fasen optimal am Bohrumfang positioniert (Abb. 1) erschließen neue Anwendungen. Diese zusätzlichen Führungsfasen stabilisieren bereits in der Anbohrfase entscheidend das weitere Bohrverhalten.

4 chamfer are optimal ajustet on the drill-diameter (see picture 1) develops new application. This additional guide-chamfer stabilizes already on the very beginning of drilling and is responsible for the further drilling process.

3 Mit IQ-Drill garantieren wir eine maximale Fluchtungsgenauigkeit (Abb. 2) und Koaxialität bei extremen Bohrtiefen besonders über 5xD Bohrtiefe.

IQ-Drill guarantees maximal alignment accuracy (see picture 2) and coaxiality in particular for drilling depths exceeding 5xD.

4 Durch das einzigartige Eigenzentrierverhalten, auch bei unterbrochenem Schnitt, (Abb. 3) bleibt die Rundheit und Fluchtungsgenauigkeit mit IQ-Drill nahezu konstant.

Because of the extraordinary self-centering-ability, also by interrupting drill holes (see picture 3), the alignment and concentricity stays almost constant.

5 Vorteile beim Einsatz mit IQ-Drill · Advantages IQ-Drill:

- kein Anzentrieren / no center drilling
- kein Vorbohren / no predrilling
- kein Aufbohren / no counterboring
- keine Bohrbuchse / no drill bushing
- hohe Oberflächenqualität / Reibqualität
- high surface quality / reamer quality
- hohe Fluchtungsgenauigkeit / high alignment accuracy
- Toleranz H7 / tolerance H7

H7	Bohrungstoleranz / Hole tolerance		
3-6	-0/+0,012	10-18	-0/+0,018
6-10	-0/+0,015	18-30	-0/+0,021

m7	Bohrertoleranz / Drill tolerance		
3-6	+0,004	10-18	+0,007
	+0,016		+0,025
6-10	+0,006	18-30	+0,008
	+0,021		+0,029

**IQ-DRILL** Vollhartmetall-Hochleistungsbohrer für Bohrung H7, 4 Fasenbohrer  
Solid carbide twist IQ-drill for drill hole tolerances H7, 4 chamfer drill

22 0419

- UNI
- STAHL  
steel
- INOX  
Edelstahl  
STAINLESS STEEL
- GJL
- GJS
- GTW  
GTS
- kurz-  
spanend  
short chip

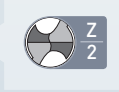
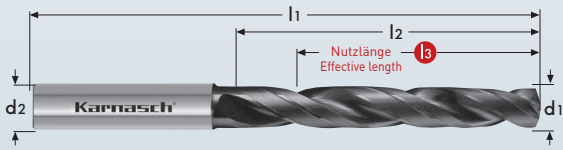

H7	Bohrungstoleranz Hole tolerance			
3-6	-0/+0,012	10-18	-0/+0,018	
6-10	-0/+0,015	18-30	-0/+0,021	

Art.	d1 H7	l3	l2	l1	d2 h6	€
22 0419 0300 023	• 3,0	23	28	66	6,0	63,00
22 0419 0400 029	• 4,0	29	36	74	6,0	63,00
22 0419 0500 035	• 5,0	35	44	82	6,0	63,00
22 0419 0600 035	• 6,0	35	44	82	6,0	63,00
22 0419 0800 043	• 8,0	43	53	91	8,0	75,00
22 0419 1000 049	• 10,0	49	61	103	10,0	81,00
22 0419 1200 056	• 12,0	56	71	118	12,0	118,00

Zwischenabmessungen sind kurzfristig lieferbar  
Intermediate sizes are available at short notice

<b>MICRO GRAIN</b>	<b>DIN 6537</b>
<b>N</b>	<b>DIN 6535 Form HA</b>
	<b>HSC HPC</b>
	<b>XFN-2 NANO</b>

Schnittdaten Cutting data	Zeichnungen Drawings
1252	DXF/STEP

**IQ-DRILL** Vollhartmetall-Hochleistungsbohrer für Bohrung H7, 4 Fasen  
Solid carbide twist IQ-drill for drill hole tolerances H7, 4 chamfer drill

22 0425

- UNI
- STAHL  
steel
- INOX  
Edelstahl  
STAINLESS STEEL
- GJL
- GJS
- GTW  
GTS
- kurz-  
spanend  
short chip

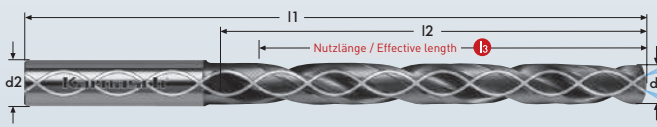

H7	Bohrungstoleranz Hole tolerance			
3-6	-0/+0,012	10-18	-0/+0,018	
6-10	-0/+0,015	18-30	-0/+0,021	

Art.	d1 H7	l3	l2	l1	d2 h6	€
22 0425 0800 064	• 8,0	64	76	114	8,0	60,00

% Sonderpreis / Sale Artikel. Lieferbar solange Vorrat.  
Special price / sale article. While stocks last.

<b>MICRO GRAIN</b>	<b>DIN 6537</b>
<b>N</b>	<b>DIN 6535 Form HAK</b>
	<b>HSC HPC</b>
	<b>XFN-2 NANO</b>

Schnittdaten Cutting data
1252

- 1
- 2
- 3
- 4
- 5
- 6
- 7
- 8
- 9

Index

22 0424

IQ-DRILL

Vollhartmetall-Hochleistungsbohrer für Bohrungen H7, Übermaß und Untermaß, 4 Fasen  
Solid carbide twist IQ-drill for drill hole tolerances H7, 4 chamfer drill

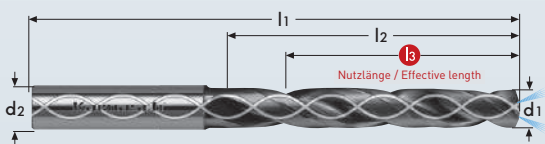

<b>MICRO GRAIN</b>	<b>DIN 6537</b>
<b>N</b>	<b>DIN 6535 Form HAK</b>
	<b>HSC HPC</b>
	<b>XFN-2 NANO</b>

**UNI**

**STAHL**  
steel  
< 1000 N/mm<sup>2</sup>

**HRC < 52**

**INOX**  
stainless steel  
< 900 N/mm<sup>2</sup> ferritic

**GJL**

**GJS**

**GTW GTS**

**kurz-spanend**  
short chip

Art.	d1	l3	l2	l1	d2 h6	€
22 0424 0298 023	• 2,98 -0,002/+0,004	23	28	66	6	137,00
22 0424 0299 023	• 2,99 -0,002/+0,004	23	28	66	6	137,00
22 0424 0300 023	• 3,00 H7	23	28	66	6	137,00
22 0424 0301 023	• 3,01 -0,002/+0,004	23	28	66	6	137,00
22 0424 0302 023	• 3,02 -0,002/+0,004	23	28	66	6	137,00
22 0424 0398 029	• 3,98 -0,002/+0,004	29	36	74	6	137,00
22 0424 0399 029	• 3,99 -0,002/+0,004	29	36	74	6	137,00
22 0424 0400 029	• 4,00 H7	29	36	74	6	137,00
22 0424 0401 029	• 4,01 -0,002/+0,004	29	36	74	6	137,00
22 0424 0402 029	• 4,02 -0,002/+0,004	29	36	74	6	137,00
22 0424 0498 035	• 4,98 -0,002/+0,004	35	44	82	6	137,00
22 0424 0499 035	• 4,99 -0,002/+0,004	35	44	82	6	137,00
22 0424 0500 035	• 5,00 H7	35	44	82	6	137,00
22 0424 0501 035	• 5,01 -0,002/+0,004	35	44	82	6	137,00
22 0424 0502 035	• 5,02 -0,002/+0,004	35	44	82	6	137,00
22 0424 0598 035	• 5,98 -0,002/+0,004	35	44	82	6	137,00
22 0424 0599 035	• 5,99 -0,002/+0,004	35	44	82	6	137,00
22 0424 0600 035	• 6,00 H7	35	44	82	6	137,00
22 0424 0601 035	• 6,01 -0,002/+0,004	35	44	82	6	135,00
22 0424 0602 035	• 6,02 -0,002/+0,004	35	44	82	6	135,00
22 0424 0700 043	• 7,00 H7	43	53	91	8	175,00
22 0424 0798 043	• 7,98 -0,002/+0,004	43	53	91	8	175,00
22 0424 0799 043	• 7,99 -0,002/+0,004	43	53	91	8	175,00
22 0424 0800 043	• 8,00 H7	43	53	91	8	175,00
22 0424 0801 043	• 8,01 -0,002/+0,004	43	53	91	8	175,00
22 0424 0802 043	• 8,02 -0,002/+0,004	43	53	91	8	175,00
22 0424 0900 049	• 9,00 H7	49	61	103	10	198,00
22 0424 0998 049	• 9,98 -0,002/+0,004	49	61	103	10	198,00
22 0424 0999 049	• 9,99 -0,002/+0,004	49	61	103	10	198,00
22 0424 1000 049	• 10,00 H7	49	61	103	10	198,00
22 0424 1001 049	• 10,01 -0,002/+0,004	49	61	103	10	198,00
22 0424 1002 049	• 10,02 -0,002/+0,004	49	61	103	10	198,00
22 0424 1100 056	• 11,00 H7	56	71	118	12	255,00
22 0424 1200 056	• 12,00 H7	56	71	118	12	255,00

Schnittdaten  
Cutting data

Zeichnungen  
Drawings

270

DXF/STEP

H7	Bohrungstoleranz Hole tolerance
> 3-6	-0,000 +0,012
> 6-10	-0,000 +0,015
> 10-18	-0,000 +0,018
> 18-30	-0,000 +0,021

Richtwerte für den Einsatz der KARNASCH VHM-Hochleistungsbohrer mit Innenkühlung  
Recommended cutting data for solid carbide twist drill, with interior cooling supply

Werkstoffgruppe Material group	Werkstoff	Festigkeit N/mm <sup>2</sup>	Schnittgeschwindigkeit Vc m/min ±10%	Ø 2,98 - Ø 5,02		Ø 5,98 - Ø 9,00			Ø 9,98 - Ø 12,0			
				f = mm/U	n = min <sup>-1</sup>	f = mm/min	f = mm/U	n = min <sup>-1</sup>	f = mm/min	f = mm/U	n = min <sup>-1</sup>	f = mm/min
1.1	36Mn 6	< 450	110	0,18	7.000	1.260	0,24	4.200	1.000	0,30	3.100	930
1.2	CM45	<650	90	0,18	6.500	1.170	0,24	3.800	920	0,30	2.700	810
1.3	24CrMo5	<850	110	0,18	7.000	1.260	0,24	4.200	1.000	0,30	3.100	930
1.4	43CrMo4	<950	90	0,18	6.500	1.170	0,24	3.800	920	0,30	2.700	810
2.1	21MnCr5	<600	80	0,15	5.400	800	0,22	3.200	700	0,28	2.300	650
2.2	26CrMo4	<950	80	0,16	5.400	870	0,22	3.200	700	0,28	2.300	650
2.3	41CrALMo7	<1.100	60	0,15	4.200	630	0,20	2.600	520	0,26	1.800	470
2.5	34CrALS5	<1.000	80	0,15	5.400	800	0,20	3.200	640	0,26	2.300	600
2.6	31CrMoV9	>1.000	80	0,15	5.400	800	0,20	3.200	640	0,26	2.300	600
3.1	X36CrMo17	<700-1.000	45	0,08	2.800	220	0,12	1.700	200	0,18	1.000	180
3.2	X12CrS13	<700	45	0,08	2.800	220	0,12	1.700	200	0,18	1.000	180
7.1	GG15	<260 HB	110	0,24	8.000	1.900	0,30	5.200	1.550	0,40	3.400	1.350
7.2	GG40	<200 HB	90	0,24	6.700	1.600	0,30	4.200	1.250	0,40	2.800	1.120
7.3	GG650	<250 HB	80	0,20	6.400	1.300	0,25	4.000	1.000	0,35	2.600	910
7.4	GG670	<250 HB	70	0,10	4.800	480	0,12	3.000	360	0,15	2.000	300

Vollhartmetall-Hochleistungsbohrer 55-70 HRC  
Solid carbide twist drill 55-70 HRC

22 0468

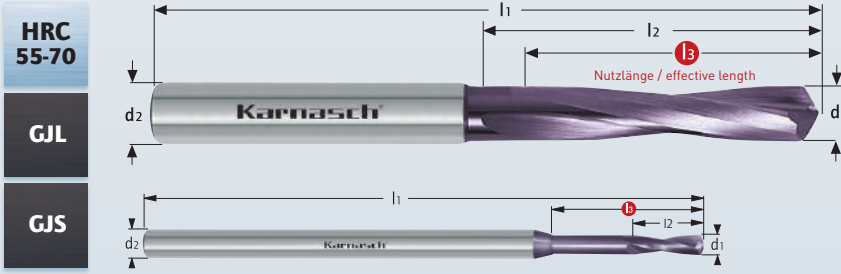

**HRC 55-70**  
**GJL**  
**GJS**  
**GTW GTS**  
kurzspanend  
short chip

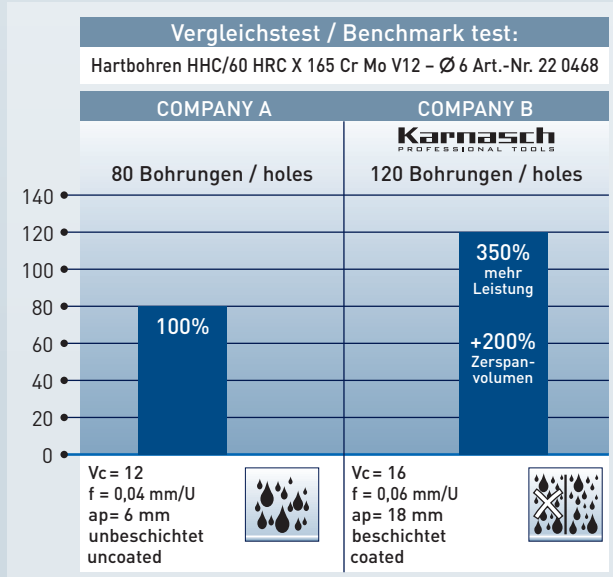

**MICRO GRAIN** **KARNASCH NORM**

**H** **DIN 6535 Form HA**

15° 140°

**HHC**

**DVC-X1**

Schnittdaten Cutting data **i** 1254

Zeichnungen Drawings **DXF/STEP**

Art.	d1 m7	l3	d2 h6	l1	l2	€
22 0468 0030	• 0,3	2,5	3	38	0,9	74,00
22 0468 0040	• 0,4	3	3	38	1,2	74,00
22 0468 0050	• 0,5	4	3	38	1,5	74,00
22 0468 0060	• 0,6	4,5	3	38	1,8	74,00
22 0468 0070	• 0,7	5,5	3	38	2,1	74,00
22 0468 0080	• 0,8	6,5	3	38	2,4	74,00
22 0468 0090	• 0,9	7,5	3	38	2,7	74,00
22 0468 0100	• 1,0	8	3	38	3,0	74,00
22 0468 0110	• 1,1	8	3	50	3,3	78,00
22 0468 0120	• 1,2	10	3	50	3,6	78,00
22 0468 0130	• 1,3	12	3	50	3,9	78,00
22 0468 0140	• 1,4	12	3	50	4,2	78,00
22 0468 0150	• 1,5	12	3	50	4,5	78,00
22 0468 0160	• 1,6	15	3	50	4,8	78,00
22 0468 0170	• 1,7	15	3	50	5,1	78,00
22 0468 0180	• 1,8	15	3	50	5,4	78,00
22 0468 0190	• 1,9	15	3	50	5,8	78,00
22 0468 0200	• 2,0	16	3	50	6,0	78,00
22 0468 0260	• 2,6/M3 x 0,5	6	3	46	16	64,00
22 0468 0300	• 3,0	6	3	46	16	64,00
22 0468 0320	• 3,2	6	4	48	16	64,00
22 0468 0330	• 3,3	6	4	48	16	64,00
22 0468 0340	• 3,4	10	4	50	20	64,00
22 0468 0350	• 3,5/M4 x 0,7	10	4	50	20	64,00
22 0468 0380	• 3,8	12	4	52	22	64,00
22 0468 0390	• 3,9	12	4	52	22	64,00
22 0468 0400	• 4,0	12	4	52	22	64,00
22 0468 0410	• 4,1	15	6	65	25	73,50
22 0468 0420	• 4,2	15	6	65	25	73,50
22 0468 0430	• 4,3	15	6	68	28	73,50
22 0468 0440	• 4,4/M5 x 0,8	15	6	68	28	73,50
22 0468 0450	• 4,5	15	6	68	28	73,50
22 0468 0470	• 4,7	15	6	68	28	73,50
22 0468 0480	• 4,8	18	6	72	32	76,50
22 0468 0490	• 4,9	18	6	72	32	76,50
22 0468 0500	• 5,0	18	6	72	32	76,50
22 0468 0510	• 5,1	18	6	72	32	76,50
22 0468 0520	• 5,2	18	6	72	32	76,50
22 0468 0530	• 5,3/M6 x 1	18	6	72	32	76,50
22 0468 0550	• 5,5	18	6	75	35	76,50

Art.	d1 m7	l3	d2 h6	l1	l2	€
22 0468 0560	• 5,6	18	6	75	35	76,50
22 0468 0570	• 5,7	18	6	75	35	76,50
22 0468 0580	• 5,8	18	6	75	35	76,50
22 0468 0590	• 5,9	18	6	75	35	76,50
22 0468 0600	• 6,0	18	6	75	35	76,50
22 0468 0610	• 6,1	25	8	80	40	95,50
22 0468 0640	• 6,4	25	8	80	40	95,50
22 0468 0650	• 6,5	25	8	80	40	95,50
22 0468 0660	• 6,6	25	8	80	40	95,50
22 0468 0670	• 6,7	25	8	80	40	95,50
22 0468 0680	• 6,8	30	8	85	45	99,00
22 0468 0690	• 6,9	30	8	85	45	99,00
22 0468 0700	• 7,0	30	8	85	45	99,00
22 0468 0710	• 7,1/M8 x 1,25	30	8	85	45	99,00
22 0468 0720	• 7,2	30	8	85	45	99,00
22 0468 0730	• 7,3/M8 x 1	30	8	85	45	99,00
22 0468 0750	• 7,5	30	8	85	45	99,00
22 0468 0760	• 7,6	35	8	98	50	125,50
22 0468 0780	• 7,8	35	8	98	50	125,50
22 0468 0800	• 8,0	35	8	98	50	125,50
22 0468 0850	• 8,5	35	10	98	50	125,50
22 0468 0860	• 8,6	42	10	105	57	125,50
22 0468 0880	• 8,8/M10 x 1,5	42	10	105	57	125,50
22 0468 0930	• 9,3/M10 x 1,0	42	10	105	57	125,50
22 0468 0950	• 9,5	42	10	105	57	75,31
22 0468 0970	• 9,7	45	10	111	63	125,50
22 0468 0980	• 9,8	45	10	111	63	125,50
22 0468 1000	• 10,0	45	10	111	63	125,50
22 0468 1020	• 10,2	45	10	111	63	152,00
22 0468 1030	• 10,3	45	10	111	63	152,00
22 0468 1050	• 10,5/M12 x 1,75	45	12	111	63	152,00
22 0468 1080	• 10,8/M12 x 1,5	50	12	111	63	154,00
22 0468 1100	• 11,0	50	12	119	71	154,00
22 0468 1150	• 11,5	50	12	119	71	94,80
22 0468 1190	• 11,9	50	12	119	71	158,00
22 0468 1200	• 12,0	50	12	119	71	158,00
22 0468 1300	• 13,0	55	14	125	77	187,00
22 0468 1400	• 14,0	55	14	125	77	187,00

% Sonderpreis / Sale Artikel. Lieferbar solange Vorrat.  
Special price / sale article. While stocks last.

1

2

3

4

5

6

7

8

9

**Index**

## 22 0471

### Hochleistungs-Vollhartmetall-Stufenbohrer High capacity solid carbide twist drill

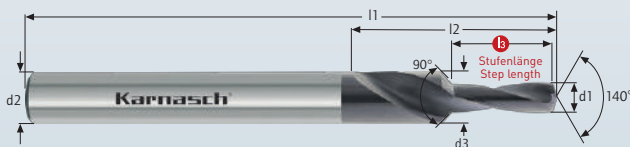

- UNI
- STAHL  
steel
- INOX  
Edelstahl  
STAINLESS STEEL
- GJL
- GJS
- GTW  
GTS
- HRC  
< 52
- kurz-  
spanend  
short chip

Art.	Gewinde Ø	d1 m7	d2 h6	d3 h8	l3	l2	l1	€
22 0471 03	% M 3	2,5	6,0	6	8,8	20	62	21,00
22 0471 04	% M 4	3,3	6,0	6	11,4	24	62	24,00
22 0471 05	% M 5	4,2	6,0	6	13,6	28	66	27,60
22 0471 06	% M 6	5,0	8,0	8	16,5	34	79	34,20
22 0471 08	% M 8	6,8	10,0	10	21,0	47	89	55,20
22 0471 10	% M 10	8,5	12,0	12	25,5	55	102	67,80
22 0471 12	% M 12	10,2	14,0	14	30,0	60	107	95,40
22 0471 14	% M 14	12,0	16,0	16	34,5	65	115	111,60
22 0471 16	% M 16	14,0	18,0	18	38,5	73	123	119,40

% Sonderpreis / Sale Artikel. Lieferbar solange Vorrat.  
Special price / sale article. While stocks last.  
Weitere Stufenbohrer in Qualität HSS-XE siehe Seite 274-279  
More subland drills in quality HSS-XE see page 274-279

MICRO GRAIN	KARNASCH NORM
N	DIN 6535 Form HA
	HSC HPC
	DVC-X2

Schnittdaten  
Cutting data

1252

## 22 0473

### Hochleistungs-Vollhartmetall-Mehrfasen-Stufenbohrer, mit Innenkühlung High capacity Solid carbide subland twist drill, with interior cooling

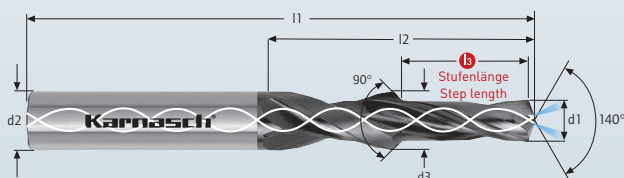

- UNI
- STAHL  
steel
- INOX  
Edelstahl  
STAINLESS STEEL
- GJL
- GJS
- GTW  
GTS
- HRC  
< 45
- kurz-  
spanend  
short chip

Art.	Gewinde Ø	d1 m7	d2 h6	d3 h8	l3	l2	l1	€
22 0473 04	• M 4	3,3	6,0	6	11,4	24	62	70,00
22 0473 05	• M 5	4,2	6,0	6	13,6	28	66	78,00
22 0473 06	• M 6	5,0	8,0	8	16,5	34	79	98,00
22 0473 08	• M 8	6,8	10,0	10	21,0	47	89	155,00
22 0473 10	• M 10	8,5	12,0	12	25,5	55	102	189,00
22 0473 12	• M 12	10,2	14,0	14	30,0	60	107	256,00
22 0473 14	% M 14	12,0	16,0	16	34,5	65	115	178,20
22 0473 16	% M 16	14,0	18,0	18	38,5	73	123	201,00

% Sonderpreis / Sale Artikel. Lieferbar solange Vorrat.  
Special price / sale article. While stocks last.  
Weitere Stufenbohrer in Qualität HSS-XE siehe Seite 274-279  
More subland drills in quality HSS-XE see page 274-279

MICRO GRAIN	KARNASCH NORM
N	DIN 6535 Form HAK
	HSC HPC
	DVC-X2

Schnittdaten  
Cutting data

Zeichnungen  
Drawings

1252

DXF/STEP

Vollhartmetall-Hochleistungsbohrer und Aufbohrer, 3 Schneiden  
Solid carbide twist drill/cordrill, 3 cutting edges

22 0520

- GJL**
- GJS**
- GTW  
GTS**
- GRAPHIT  
graphite**
- HRC  
< 52**
- kurz-  
spanend  
short chip**

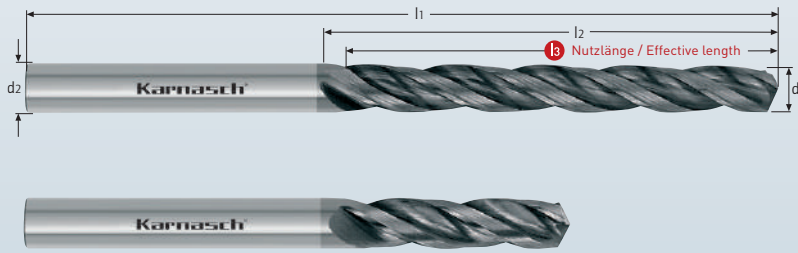

Art.	d1 h7	l3	l2	l1	d2 <sup>-0,002</sup> / <sub>-0,005</sub>	€
22 0520 0300 012	3,0	12	16	46	3	13,51
22 0520 0400 017	4,0	17	22	55	4	13,51
22 0520 0400 038	4,0	38	43	75	4	14,71
22 0520 0600 021	6,0	21	28	66	6	17,40
22 0520 0600 050	6,0	50	57	93	6	23,71
22 0520 0700 026	7,0	26	34	74	7	20,40
22 0520 0800 065	8,0	65	75	117	8	37,80
22 0520 0900 029	9,0	29	40	84	9	30,00
22 0520 0900 070	9,0	70	80	125	9	56,71
22 0520 1000 031	10,0	31	44	90	10	37,80
22 0520 1000 075	10,0	75	87	135	10	69,60
22 0520 1200 037	12,0	37	50	102	12	65,71
22 0520 1200 088	12,0	88	100	150	12	99,31

% Sonderpreis / Sale Artikel. Lieferbar solange Vorrat.  
Special price / sale article. While stocks last.

- MICRO GRAIN** KARNASCH NORM
- SPEZIAL** DIN 6535 Form HA
- 30° 140°
- HSC HPC
- DVC-X2

Schnittdaten  
Cutting data

**i**  
1250



Vollhartmetall-Hochleistungsbohrer und Aufbohrer, 3 Schneiden  
Solid carbide twist drill/cordrill, 3 cutting edges

22 0525

- GJL**
- GJS**
- GTW  
GTS**
- GRAPHIT  
graphite**
- HRC  
< 52**
- kurz-  
spanend  
short chip**

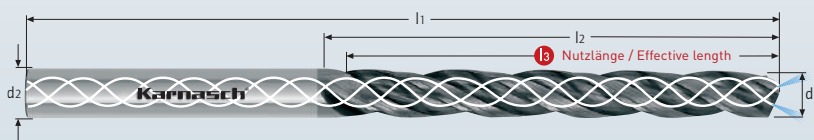

Art.	d1 h7	l3	l2	l1	d2 <sup>-0,002</sup> / <sub>-0,005</sub>	€
22 0525 0400 040	4,0	40	43	82	6	48,60
22 0525 0500 045	5,0	45	52	92	6	48,60
22 0525 0600 050	6,0	50	57	95	6	48,60
22 0525 0800 065	8,0	65	75	115	8	72,00
22 0525 1200 088	12,0	88	100	150	12	141,91

% Sonderpreis / Sale Artikel. Lieferbar solange Vorrat.  
Special price / sale article. While stocks last.

- MICRO GRAIN** KARNASCH NORM
- SPEZIAL** DIN 6535 Form HAK
- 30° 140°
- HSC HPC
- DVC-X2

Schnittdaten  
Cutting data

**i**  
1250





## ANWENDUNG · APPLICATION

Stahl	Edelstahl	Grauguss	Alu	Kupfer, Messing, Zinn	Kunststoffe
Steel	Stainless	Grey cast iron	Alu	Copper, brass, tin	GFK/CFK
< 900 N	< 900 N		> 10% Si		Plastics GRP/CRP

## EIGENSCHAFTEN · PROPERTIES

### HSS-XE Stahl

Gefertigt aus hochlegiertem Spezialstahl "XE" für wesentlich höhere Standzeiten gegenüber HSS-Stähle.

### Zum Senken in folgende Materialien:

- Edelstähle (V2A)
- Stahl
- Guss
- Bunt- und Leichtmetalle

Bohr- und Senkstufe sind jeweils mit eigenen Span-Nuten und Führungsfasen gefertigt. Dadurch mehrmaliges Nachschleifen möglich.

### HSS-XE steel

Made of high-alloyed special steel „XE“ for considerably longer service life than HSS-steel.

### For countersinking in materials:

- High-alloyed chromium steel such as stainless (V2A)
- Steel
- Cast iron
- Non ferrous metals

Drill and counterbore each with its own chip flutes and guide chamfers. This means it can be reground many times.

## 40 1010

HSS-XE Mehrfasen-Stufenbohrer, DIN 8374, 90°, Gütegrad fein für Durchgangsloch  
HSS-XE subland drill, DIN 8374, 90°, fine grade for through holes

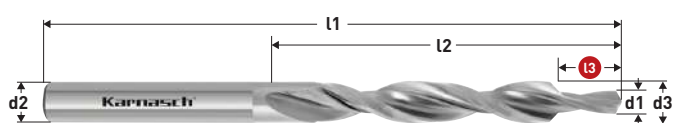

Art.	Für Gewinde For thread Ø	d1 h9 mm	d2 h8 mm	d3 h8 mm	L3 mm	L2 mm	L1 mm	€
40 1010 030	M 3	• 3,2	6,0	6,0	9,0	57,0	93,0	23,45
40 1010 040	M 4	• 4,3	8,0	8,0	11,0	75,0	117,0	26,70
40 1010 050	M 5	• 5,3	10,0	10,0	13,0	87,0	133,0	33,80
40 1010 060	M 6	• 6,4	11,5	11,5	15,0	94,0	142,0	37,80
40 1010 080	M 8	• 8,4	15,0	15,0	19,0	114,0	169,0	62,85
40 1010 100	M 10	• 10,5	19,0	19,0	23,0	135,0	198,0	96,45



**Verwendung:** Für Schrauben- und Durchgangslöcher nach DIN-ISO 273 und Senkungen nach DIN 74 Blatt 1, Form A, Gütegrad fein. Für Senkschrauben nach ISO 2009, 2010, 7046 / DIN 963, 964, 965, 966.

**Use:** For through holes for screws DIN-ISO 273 and countersinks to DIN 74 sheet 1, form A, fine grade. For countersunk screws to ISO 2009, 2010, 7046 / DIN 963, 964, 965, 966.

## 40 1020

HSS-XE Mehrfasen-Stufenbohrer, DIN 8376, 180°, Gütegrad mittel für Durchgangsloch  
HSS-XE subland drill, DIN 8376, 180°, medium grade for through holes



Art.	Für Gewinde For thread Ø	d1 h9 mm	d2 h8 mm	d3 h8 mm	L3 mm	L2 mm	L1 mm	€
40 1020 030	M 3	• 3,4	6,5	6,5	9,0	63,0	101,0	24,85
40 1020 040	M 4	• 4,5	8,0	8,0	11,0	75,0	117,0	26,50
40 1020 050	M 5	• 5,5	10,0	10,0	13,0	87,0	133,0	31,85
40 1020 060	M 6	• 6,6	11,0	11,0	15,0	94,0	142,0	36,75
40 1020 080	M 8	• 9,0	15,0	15,0	19,0	114,0	169,0	46,70
40 1020 100	M 10	• 11,0	18,0	18,0	23,0	130,0	191,0	96,05



**Verwendung:** Für Schrauben- und Durchgangslöcher nach DIN-ISO 273 und Schraubkopfsenkungen Form H, J, K. Gütegrad mittel nach DIN 74 Blatt 2.

**Use:** For screw through holes to DIN-ISO 273 and screw head counterbores shape H, J, K. Medium grade to DIN 74 sheet 2.

## 40 1030

HSS-XE Mehrfasen-Stufenbohrer, DIN 8378, für Kernloch, 90° Ansenkung  
HSS-XE subland drill, DIN 8378, for tapping holes, 90° countersink

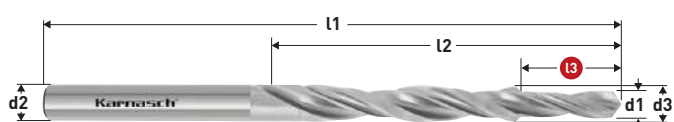

Art.	Für Gewinde For thread Ø	d1 h9 mm	d2 h8 mm	d3 h8 mm	L3 mm	L2 mm	L1 mm	€
40 1030 030	M 3	• 2,5	3,4	3,4	8,8	39,0	70,0	19,45
40 1030 040	M 4	• 3,3	4,5	4,5	11,4	47,0	80,0	21,10
40 1030 050	M 5	• 4,2	5,5	5,5	13,6	57,0	93,0	21,65
40 1030 060	M 6	• 5,0	6,6	6,6	16,5	63,0	101,0	24,60
40 1030 080	M 8	• 6,8	9,0	9,0	21,0	81,0	125,0	28,15
40 1030 100	M 10	• 8,5	11,0	11,0	25,5	94,0	142,0	36,10
40 1030 120	M 12	• 10,2	13,5	13,5	30,0	108,0	160,0	46,15



**Verwendung:** Gewindekernloch und Ansenkung werden genau fluchtend zueinander in einem Arbeitsgang gefertigt. Für Gewinde-Kernloch-Bohrungen nach DIN 336 Blatt 1 mit Ansenkungen 90° (ähnlich DIN 69, Gütegrad mittel).

**Use:** Tapping hole and countersink are produced in one operation. For drilling tapping holes to DIN 336 sheet 1 with 90° countersinking (similar DIN 69, medium grade).

Schnittdaten  
Cutting data

Film  
Movie



1319

**ANWENDUNG · APPLICATION**

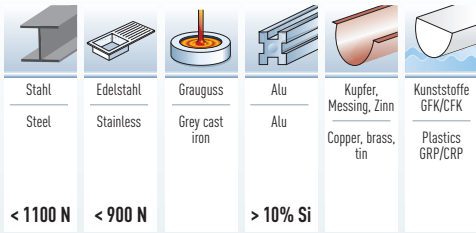

Bohr- und Senkstufe sind jeweils mit eigenen Span-Nuten und Führungsfasen gefertigt. Dadurch mehrmaliges Nachschleifen möglich.  
 Drill and counterbore each with its own chip flutes and guide chamfers. This means it can be reground many times.

**EIGENSCHAFTEN · PROPERTIES**

**HSS-XE Stahl + TITAN-TEC beschichtet**  
 Gefertigt aus hochlegiertem Spezialstahl „XE“ für wesentlich höhere Standzeiten gegenüber HSS-Stähle.  
 TITAN-TEC Beschichtung für eine nochmalige wesentliche Erhöhung der Standzeit auch bei Trockenbearbeitung (ohne/wenig Kühlung)

- Zum Senken in folgende Materialien:**
- Edelstähle (V2A / V4A)
  - Stahl
  - Guss
  - Bunt- und Leichtmetalle

**HSS-XE steel + TITAN-TEC coated**  
 Made of high-alloyed special steel „XE“ for considerably longer service life than HSS-steel.  
 TITAN-TEC coating for a further substantial increase in service life also when machining dry (no/less cooling)

- For countersinking in materials:**
- High-alloyed chromium steel such as stainless (V2A / V4A)
  - Acid resistant steel
  - Steel
  - Cast iron
  - Non ferrous metals

**HSS-XE + TITAN-TEC Mehrfasen-Stufenbohrer, DIN 8374, 90°, Gütegrad fein für Durchgangsloch**  
**HSS-XE + TITAN-TEC subland drill, DIN 8374, 90°, fine grade for through holes**

**40 2010**

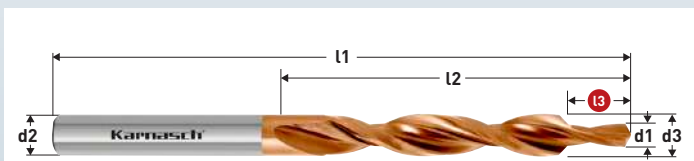

Art.	Für Gewinde Ø For thread	d1 h9 mm	d2 h8 mm	d3 h8 mm	L3 mm	L2 mm	L1 mm	€
40 2010 030	M 3	• 3,2	6,0	6,0	9,0	57,0	93,0	29,30
40 2010 040	M 4	• 4,3	8,0	8,0	11,0	75,0	117,0	33,35
40 2010 050	M 5	• 5,3	10,0	10,0	13,0	87,0	133,0	42,25
40 2010 060	M 6	• 6,4	11,5	11,5	15,0	94,0	142,0	47,20
40 2010 080	M 8	• 8,4	15,0	15,0	19,0	114,0	169,0	78,55
40 2010 100	M 10	• 10,5	19,0	19,0	23,0	135,0	198,0	120,55



**Verwendung:** Für Schrauben- und Durchgangslöcher nach DIN-ISO 273 und Senkungen nach DIN 74 Blatt 1, Form A, Gütegrad fein. Für Senkschrauben nach ISO 2009, 2010, 7046 / DIN 963, 964, 965, 966.

**Use:** For through holes for screws DIN-ISO 273 and countersinks to DIN 74 sheet 1, form A, fine grade. For countersunk screws to ISO 2009, 2010, 7046 / DIN 963, 964, 965, 966.

**HSS-XE + TITAN-TEC Mehrfasen-Stufenbohrer, DIN 8376, 180°, Gütegrad mittel für Durchgangsloch**  
**HSS-XE + TITAN-TEC subland drill, DIN 8376, 180°, medium grade for through holes**

**40 2020**

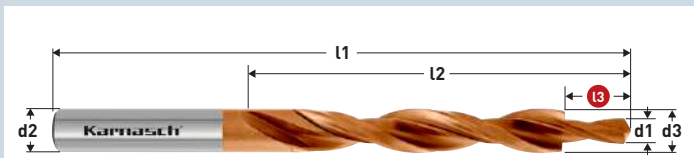

Art.	Für Gewinde Ø For thread	d1 h9 mm	d2 h8 mm	d3 h8 mm	L3 mm	L2 mm	L1 mm	€
40 2020 030	M 3	• 3,4	6,5	6,5	9,0	63,0	101,0	31,05
40 2020 040	M 4	• 4,5	8,0	8,0	11,0	75,0	117,0	33,10
40 2020 050	M 5	• 5,5	10,0	10,0	13,0	87,0	133,0	39,80
40 2020 060	M 6	• 6,6	11,0	11,0	15,0	94,0	142,0	45,95
40 2020 080	M 8	• 9,0	15,0	15,0	19,0	114,0	169,0	58,40
40 2020 100	M 10	• 11,0	18,0	18,0	23,0	130,0	191,0	120,05



**Verwendung:** Für Schrauben- und Durchgangslöcher nach DIN-ISO 273 und Schraubenkopfsenkungen Form H, J, K. Gütegrad mittel nach DIN 74 Blatt 2.

**Use:** For screw through holes to DIN-ISO 273 and screw head counterbores shape H, J, K. Medium grade to DIN 74 sheet 2.

**HSS-XE + TITAN-TEC Mehrfasen-Stufenbohrer, DIN 8378, für Kernloch, 90° Ansenkung**  
**HSS-XE + TITAN-TEC subland drill, DIN 8378, for tapping holes, 90° countersink**

**40 2030**

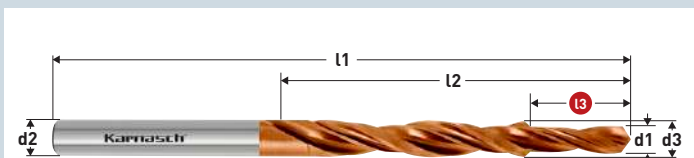

Art.	Für Gewinde Ø For thread	d1 h9 mm	d2 h8 mm	d3 h8 mm	L3 mm	L2 mm	L1 mm	€
40 2030 030	M 3	• 2,5	3,4	3,4	8,8	39,0	70,0	24,35
40 2030 040	M 4	• 3,3	4,5	4,5	11,4	47,0	80,0	26,35
40 2030 050	M 5	• 4,2	5,5	5,5	13,6	57,0	93,0	27,05
40 2030 060	M 6	• 5,0	6,6	6,6	16,5	63,0	101,0	30,70
40 2030 080	M 8	• 6,8	9,0	9,0	21,0	81,0	125,0	35,15
40 2030 100	M 10	• 8,5	11,0	11,0	25,5	94,0	142,0	45,15
40 2030 120	M 12	• 10,2	13,5	13,5	30,0	108,0	160,0	57,70



**Verwendung:** Gewindekernloch und Ansenkung werden genau fluchtend zueinander in einem Arbeitsgang gefertigt. Für Gewinde-Kernloch-Bohrungen nach DIN 336 Blatt 1 mit Ansenkungen 90° (ähnlich DIN 69, Gütegrad mittel).

**Use:** Tapping hole and countersink are produced in one operation. For drilling tapping holes to DIN 336 sheet 1 with 90° countersinking (similar DIN 69, medium grade).

Schnittdaten  
Cutting data

Film  
Movie



1319

275



## ANWENDUNG · APPLICATION

Stahl	Edelstahl	Grauguss	Alu	Kupfer, Messing, Zinn	Kunststoffe
Steel	Stainless	Grey cast iron	Alu	Copper, brass, tin	GFK/CFK
< 900 N	< 900 N		> 10% Si		Plastics GRP/CRP

## EIGENSCHAFTEN · PROPERTIES

### HSS-XE Stahl

Fertigt aus hochlegiertem Spezialstahl "XE" für wesentlich höhere Standzeiten gegenüber HSS-Stähle.

#### Zum Senken in folgende Materialien:

- Edelstähle (V2A)
- Stahl
- Guss
- Bunt- und Leichtmetalle

### HSS-XE steel

Made of high-alloyed special steel „XE“ for considerably longer service life than HSS-steel.

#### For countersinking in materials:

- High-alloyed chromium steel such as stainless (V2A)
- Steel
- Cast iron
- Non ferrous metals

## 40 1040

HSS-XE Kurzstufenbohrer für Durchgangsloch 90° (Senkschrauben)  
HSS-XE stub subland drill for through holes 90° (countersunk screws)

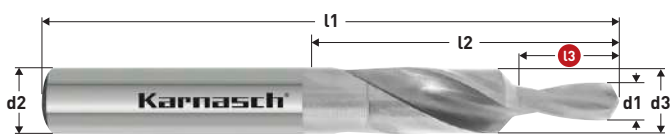

Art.	Für Gewinde Ø For thread Ø	d1 h8 mm	d2 h8 mm	d3 h8 mm	L3 mm	L2 mm	L1 mm	€
40 1040 030	M 3	• 3,2	6,0	6,0	9,0	28,0	66,0	15,45
40 1040 040	M 4	• 4,3	8,0	8,0	11,0	37,0	79,0	17,70
40 1040 050	M 5	• 5,3	10,0	10,0	13,0	43,0	89,0	22,05
40 1040 060	M 6	• 6,4	11,5	11,5	15,0	47,0	95,0	25,90
40 1040 080	M 8	• 8,4	15,0	15,0	19,0	56,0	111,0	30,25
40 1040 100	M 10	• 10,5	19,0	19,0	23,0	64,0	127,0	45,25



**Verwendung:** Besonders geeignet für NC-Maschinen, da hohe Positionsgenauigkeit, beste Zentriereigenschaft und sehr stabil. Das vorherige Zentrieren kann deshalb oft entfallen. Sehr stabile und enge Rundlauf-toleranzen zwischen Bohr- und Senkdurchmesser garantieren exakte Fluchtung. Für Schrauben-Durchgangslöcher nach DIN-ISO 273 und Senkungen nach DIN 74, Blatt 1, Form A, Gütegrad fein. Für Schrauben nach ISO 2009, 2010, 7046, 7047 (DIN 963, 964, 965, 966).

**Use:** Particular suitable for NC machines due to high positional accuracy, excellent centering properties and great sturdiness. The preceding centering operation can thus often be omitted. Very sturdy and tight concentricity tolerances between drill Ø and counterbore Ø guarantee exact alignment. For through holes for screws to DIN-ISO 273 and counter-sinks to DIN 74, sheet 1 form A fine grade. For screws to ISO 2009, 2010, 7046, 7047 (DIN 963, 964, 965, 966).

## 40 1050

HSS-XE Kurzstufenbohrer für Durchgangsloch 180° (Zylinderkopf-Schrauben)  
HSS-XE stub subland drill for through holes 180° (socket-head screws)

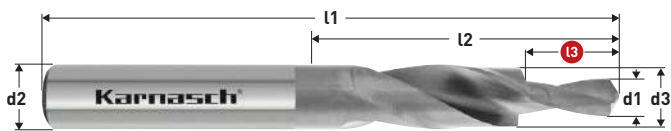

Art.	Für Gewinde Ø For thread Ø	d1 h8 mm	d2 h8 mm	d3 h8 mm	L3 mm	L2 mm	L1 mm	€
40 1050 030	M 3	• 3,4	6,0	6,0	9,0	28,0	66,0	15,15
40 1050 040	M 4	• 4,5	8,0	8,0	11,0	37,0	79,0	17,20
40 1050 050	M 5	• 5,5	10,0	10,0	13,0	43,0	89,0	21,10
40 1050 060	M 6	• 6,6	11,0	11,0	15,0	47,0	95,0	24,55
40 1050 080	M 8	• 9,0	15,0	15,0	19,0	56,0	111,0	30,85
40 1050 100	M 10	• 11,0	18,0	18,0	23,0	62,0	123,0	47,05



**Verwendung:** Sehr stabile und enge Rundlauf-toleranzen zwischen Bohr- und Senkdurchmesser garantieren exakte Fluchtung. Für Schrauben-Durchgangslöcher nach DIN-ISO 273 und Senkungen nach DIN 74, Blatt 2, Form H, J, K, Gütegrad mittel. Für Schrauben nach DIN 912, 6912, 7984, ISO 1207 (DIN 84).

**Use:** Very sturdy and tight concentricity tolerances between drill Ø and counterbore Ø guarantee exact alignment. For through holes for screws to DIN-ISO 273 and countersinking to DIN 74, sheet 2 form H, J, K, medium grade. For screws to DIN 912, 6912, 7984, ISO 1207 (DIN 84).

Schnittdaten  
Cutting data

Film  
Movie



1319



**ANWENDUNG · APPLICATION**

Stahl	Edelstahl	Grauguss	Alu	Kupfer, Messing, Zinn	Kunststoffe GFK/CFK
Steel	Stainless	Grey cast iron	Alu	Copper, brass, tin	Plastics GRP/CRP
< 1100 N	< 900 N		> 10% Si		

**EIGENSCHAFTEN · PROPERTIES**

**HSS-XE Stahl + TITAN-TEC beschichtet**  
 Gefertigt aus hochlegiertem Spezialstahl „XE“ für wesentlich höhere Standzeiten gegenüber HSS-Stähle.  
 TITAN-TEC Beschichtung für eine nochmalige wesentliche Erhöhung der Standzeit auch bei Trockenbearbeitung (ohne/wenig Kühlung)

- Zum Senken in folgende Materialien:**
- Edelstähle (V2A / V4A)
  - Stahl
  - Guss
  - Bunt- und Leichtmetalle

**HSS-XE steel + TITAN-TEC coated**  
 Made of high-alloyed special steel „XE“ for considerably longer service life than HSS-steel.  
 TITAN-TEC coating for a further substantial increase in service life also when machining dry (no/less cooling)

- For countersinking in materials:**
- High-alloyed chromium steel such as stainless (V2A / V4A)
  - Acid resistant steel
  - Steel
  - Cast iron
  - Non ferrous metals

**HSS-XE + TITAN-TEC Kurzstufenbohrer für Durchgangsloch 90° (Senkschrauben)**  
**HSS-XE + TITAN-TEC stub subland drill for through holes 90° (countersunk screws)**

**40 2040**

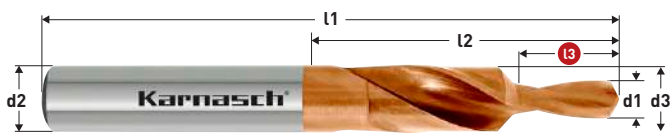

Art.	Für Gewinde Ø For thread Ø	d1 h8 mm	d2 h8 mm	d3 h8 mm	L3 mm	L2 mm	L1 mm	€
40 2040 030	M 3	• 3,2	6,0	6,0	9,0	28,0	66,0	19,30
40 2040 040	M 4	• 4,3	8,0	8,0	11,0	37,0	79,0	22,15
40 2040 050	M 5	• 5,3	10,0	10,0	13,0	43,0	89,0	27,55
40 2040 060	M 6	• 6,4	11,5	11,5	15,0	47,0	95,0	32,35
40 2040 080	M 8	• 8,4	15,0	15,0	19,0	56,0	111,0	37,80
40 2040 100	M 10	• 10,5	19,0	19,0	23,0	64,0	127,0	56,55



**Verwendung:** Besonders geeignet für NC-Maschinen, da hohe Positionsgenauigkeit, beste Zentriereigenschaft und sehr stabil. Das vorherige Zentrieren kann deshalb oft entfallen. Sehr stabile und enge Rundlauf-toleranzen zwischen Bohr- und Senkdurchmesser garantieren exakte Fluchtung. Für Schrauben-Durchgangslöcher nach DIN-ISO 273 und Senkungen nach DIN 74, Blatt 1, Form A, Gütegrad fein. Für Schrauben nach ISO 2009, 2010, 7046, 7047 (DIN 963, 964, 965, 966).

**Use:** Particular suitable for NC machines due to high positional accuracy, excellent centering properties and great sturdiness. The preceding centering operation can thus often be omitted. Very sturdy and tight concentricity tolerances between drill Ø and counterbore Ø guarantee exact alignment. For through holes for screws to DIN-ISO 273 and countersinks to DIN 74, sheet 1 form A fine grade. For screws to ISO 2009, 2010, 7046, 7047 (DIN 963, 964, 965, 966)

**HSS-XE + TITAN-TEC Kurzstufenbohrer für Durchgangsloch 180° (Zylinderkopf-Schrauben)**  
**HSS-XE + TITAN-TEC stub subland drill for through holes 180° (socket-head screws)**

**40 2050**

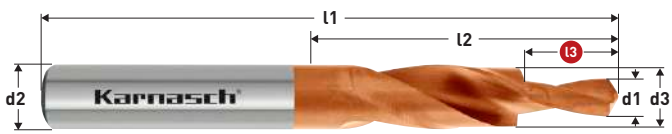

Art.	Für Gewinde Ø For thread Ø	d1 h8 mm	d2 h8 mm	d3 h8 mm	L3 mm	L2 mm	L1 mm	€
40 2050 030	M 3	• 3,4	6,0	6,0	9,0	28,0	66,0	18,95
40 2050 040	M 4	• 4,5	8,0	8,0	11,0	37,0	79,0	21,50
40 2050 050	M 5	• 5,5	10,0	10,0	13,0	43,0	89,0	26,35
40 2050 060	M 6	• 6,6	11,0	11,0	15,0	47,0	95,0	30,70
40 2050 080	M 8	• 9,0	15,0	15,0	19,0	56,0	111,0	38,55
40 2050 100	M 10	• 11,0	18,0	18,0	23,0	62,0	123,0	58,80



**Verwendung:** Sehr stabile und enge Rundlauf-toleranzen zwischen Bohr- und Senkdurchmesser garantieren exakte Fluchtung. Für Schrauben-Durchgangslöcher nach DIN-ISO 273 und Senkungen nach DIN 74, Blatt 2, Form H, J, K, Gütegrad mittel. Für Schrauben nach DIN 912, 6912, 7984, ISO 1207 (DIN 84).

**Use:** Very sturdy and tight concentricity tolerances between drill Ø and counterbore Ø guarantee exact alignment. For through holes for screws to DIN-ISO 273 and countersinking to DIN 74, sheet 2 form H, J, K, medium grade. For screws to DIN 912, 6912, 7984, ISO 1207 (DIN 84).

Schnittdaten  
Cutting data



1319

Film  
Movie



277



## ANWENDUNG · APPLICATION

Stahl Steel	Edelstahl Stainless	Grauguss Grey cast iron	Alu Alu	Kupfer, Messing, Zinn Copper, brass, tin	Kunststoffe GFK/CFK Plastics GRP/CRP
< 900 N	< 900 N		> 10% Si		

## EIGENSCHAFTEN · PROPERTIES

### HSS-XE Stahl

Gefertigt aus hochlegiertem Spezialstahl "XE" für wesentlich höhere Standzeiten gegenüber HSS-Stählen.

#### Zum Senken in folgende Materialien:

- Edelstähle (V2A)
- Stahl
- Guss
- Bunt- und Leichtmetalle

### HSS-XE steel

Made of high-alloyed special steel „XE“ for considerably longer service life than HSS-steel.

#### For countersinking in materials:

- High-alloyed chromium steel such as stainless (V2A)
- Steel
- Cast iron
- Non ferrous metals

### 40 1060

HSS-XE Kurzstufenbohrer für Kernloch, 90° Ansenkung  
HSS-XE stub jobber drills for tapping holes, 90° countersink

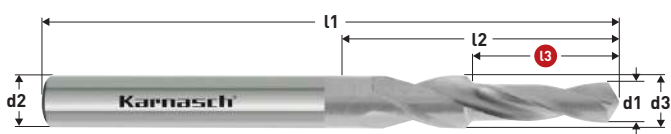

Art.	Für Gewinde Ø For thread Ø	d1 h8 mm	d2 h8 mm	d3 h8 mm	L3 mm	L2 mm	L1 mm	€
40 1060 030	M 3	• 2,5	3,4	3,4	8,8	20,0	52,0	13,65
40 1060 040	M 4	• 3,3	4,5	4,5	11,4	24,0	58,0	13,95
40 1060 050	M 5	• 4,2	5,5	5,5	13,6	28,0	66,0	14,90
40 1060 060	M 6	• 5,0	6,6	6,6	16,5	31,0	70,0	15,50
40 1060 080	M 8	• 6,8	9,0	9,0	21,0	40,0	84,0	18,30
40 1060 100	M 10	• 8,5	11,0	11,0	25,5	47,0	95,0	23,50
40 1060 120	M 12	• 10,2	13,5	13,5	30,0	54,0	107,0	30,20



**Verwendung:** Bohrung und Senkung werden in einem Arbeitsgang genau fluchtend zueinander gefertigt. Daher sehr stabile und enge Rundlauf-toleranzen.

Besonders geeignet für NC-Maschinen, da hohe Positionsgenauigkeit, beste Zentriereigenschaft und sehr stabil. Das vorherige Zentrieren kann deshalb oft entfallen. Für Gewindekernlochbohrungen nach DIN 336 Blatt 1 mit Ansenkung 90°. Der nachfolgende Gewindebohrer schneidet dadurch nicht an der scharfen Bohrkante an.

**Use:** Hole and countersink are produced in one operation and precisely aligned. Therefore very sturdy and tight concentricity tolerances. Particular suitable for NC machines due to high positional accuracy, excellent centering properties and great sturdiness. The preceding centering operation can thus often be omitted. For thread tapping drill holes to DIN 336 sheet 1 with 90° countersink. In the following operation, the tap therefore does not have to cut into the sharp edge of the hole

### 40 1070

HSS-XE Kurzstufenbohrer mit langer Bohrstufe für Durchgangsloch 90°  
HSS-XE stub subland drill with long drilling step for through holes 90°

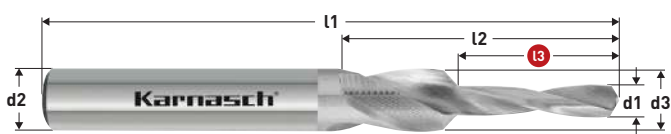

Art.	Für Gewinde Ø For thread Ø	d1 ± 0,05 mm	d2 h8 mm	d3 h9 mm	L3 mm	L2 mm	L1 mm	€
40 1070 040	M 4	• 4,3	8,6	8,6	30,0	55,0	110,0	31,05
40 1070 050	M 5	• 5,3	10,4	10,4	30,0	55,0	110,0	33,40
40 1070 060	M 6	• 6,4	12,4	12,4	30,0	55,0	110,0	36,30
40 1070 080	M 8	• 8,4	12,5	16,4	30,0	70,0	110,0	56,40
40 1070 100	M 10	• 10,5	12,5	20,4	30,0	70,0	110,0	71,00



**Verwendung:** Für Schrauben- und Durchgangslöcher nach DIN-ISO 273 und Senkungen nach DIN 74 Blatt 1 Form A, Ausführung mittel. Für Schrauben nach ISO 2009, 2010, 7046, 7047 (DIN 963, 964, 966). Besonders geeignet für Bohrungen mit gleichzeitiger Ansenkung in Profilmaterial.

**Use:** For through holes for screws DIN-ISO 273 and countersinks to DIN 74, sheet 1 form A, medium grade. For screws to ISO 2009, 2010, 7047 (DIN 963, 964, 966). Especially suitable for holes with simultaneous countersinking in profile material.

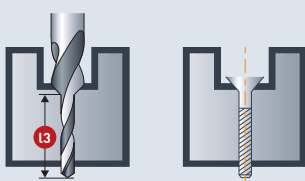

Durchgangsloch mit Senkung für Schraubenkopf in einem Arbeitsgang gebohrt.

Through hole with counterbore for screw head drilled in one operation.

Schnittdaten  
Cutting data

Film  
Movie



1319

**ANWENDUNG · APPLICATION**

Stahl	Edelstahl	Grauguss	Alu	Kupfer, Messing, Zinn	Kunststoffe GFK/CFK
Steel	Stainless	Grey cast iron	Alu	Copper, brass, tin	Plastics GRP/CRP
< 900 N	< 900 N		> 10% Si		

**EIGENSCHAFTEN · PROPERTIES**

**HSS-XE Stahl + TITAN-TEC beschichtet**  
 Gefertigt aus hochlegiertem Spezialstahl „XE“ für wesentlich höhere Standzeiten gegenüber HSS-Stähle.  
 TITAN-TEC Beschichtung für eine nochmalige wesentliche Erhöhung der Standzeit auch bei Trockenbearbeitung (ohne/wenig Kühlung)

- Zum Senken in folgende Materialien:**
- Edelstähle (V2A / V4A)
  - Stahl
  - Guss
  - Bunt- und Leichtmetalle

**HSS-XE steel + TITAN-TEC coated**  
 Made of high-alloyed special steel „XE“ for considerably longer service life than HSS-steel.  
 TITAN-TEC coating for a further substantial increase in service life also when machining dry (no/less cooling)

- For countersinking in materials:**
- High-alloyed chromium steel such as stainless (V2A / V4A)
  - Acid resistant steel
  - Steel
  - Cast iron
  - Non ferrous metals

**HSS-XE + TITAN-TEC Kurzstufenbohrer für Kernloch, 90° Ansenkung**  
**HSS-XE + TITAN-TEC stub jobber drills for tapping holes, 90° countersink**

**40 2060**

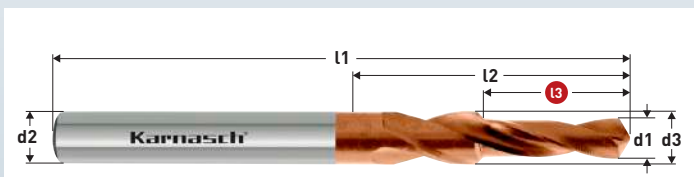

Art.	Für Gewinde For thread Ø	d1 h8 mm	d2 h8 mm	d3 h8 mm	L3 mm	L2 mm	L1 mm	€
40 2060 030	M 3	• 2,5	3,4	3,4	8,8	20,0	52,0	16,65
40 2060 040	M 4	• 3,3	4,5	4,5	11,4	24,0	58,0	17,05
40 2060 050	M 5	• 4,2	5,5	5,5	13,6	28,0	66,0	18,25
40 2060 060	M 6	• 5,0	6,6	6,6	16,5	31,0	70,0	18,95
40 2060 080	M 8	• 6,8	9,0	9,0	21,0	40,0	84,0	22,50
40 2060 100	M 10	• 8,5	11,0	11,0	25,5	47,0	95,0	28,95
40 2060 120	M 12	• 10,2	13,5	13,5	30,0	54,0	107,0	37,35

**HSS-XE** **90°** **TITAN-TEC** beschichtet / coated **DIN 1897** **118°** **Z 2**

**Verwendung:** Bohrung und Senkung werden in einem Arbeitsgang genau fluchtend zueinander gefertigt. Daher sehr stabile und enge Rundlauf toleranzen.  
 Besonders geeignet für NC-Maschinen, da hohe Positionsgenauigkeit, beste Zentriereigenschaft und sehr stabil. Das vorherige Zentrieren kann deshalb oft entfallen. Für Gewindekernlochbohrungen nach DIN 336 Blatt 1 mit Ansenkung 90°. Der nachfolgende Gewindebohrer schneidet dadurch nicht an der scharfen Bohrkante an.

**Use:** Hole and countersink are produced in one operation and precisely aligned. Therefore very sturdy and tight concentricity tolerances. Particular suitable for NC machines due to high positional accuracy, excellent centering properties and great sturdiness. The preceding operation can thus often be omitted. For thread tapping drill holes to DIN 336 sheet 1 with 90° countersink. In the following tapping operation, the tap therefore does not have to cut into the sharp edge of the hole

**HSS-XE + TITAN-TEC Kurzstufenbohrer mit langer Bohrstufe für Durchgangsloch 90°**  
**HSS-XE + TITAN-TEC stub subland drill with long drilling step for through holes 90°**

**40 2070**

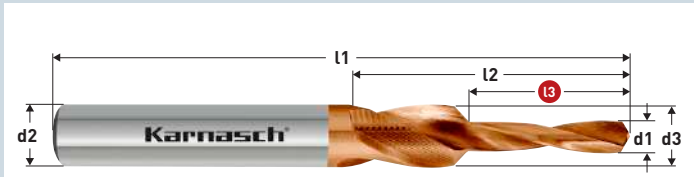

Art.	Für Gewinde For thread Ø	d1 ± 0,05 mm	d2 h8 mm	d3 h9 mm	L3 mm	L2 mm	L1 mm	€
40 2070 040	M 4	• 4,3	8,6	8,6	30,0	55,0	110,0	37,25
40 2070 050	M 5	• 5,3	10,4	10,4	30,0	55,0	110,0	40,05
40 2070 060	M 6	• 6,4	12,4	12,4	30,0	55,0	110,0	43,55
40 2070 080	M 8	• 8,4	12,5	16,4	30,0	70,0	110,0	67,65
40 2070 100	M 10	• 10,5	12,5	20,4	30,0	70,0	110,0	85,20

**HSS-XE** **90°** **KARNASCH NORM** **TITAN-TEC** beschichtet / coated **118°** **Z 2**

**Verwendung:** Für Schrauben- und Durchgangslöcher nach DIN-ISO 273 und Senkungen nach DIN 74 Blatt 1 Form A, Ausführung mittel. Für Schrauben nach ISO 2009, 2010, 7046, 7047 (DIN 963, 964, 966). Besonders geeignet für Bohrungen mit gleichzeitiger Ansenkung in Profilmaterial.

**Use:** For through holes for screws DIN-ISO 273 and countersinks to DIN 74, sheet 1 form A, medium grade. For screws to ISO 2009, 2010, 7047 (DIN 963, 964, 966). Especially suitable for holes with simultaneous countersinking in profile material.

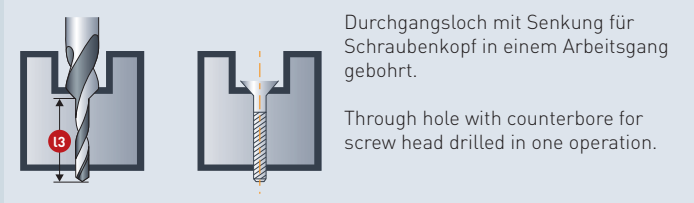

Schnittdaten Cutting data **i** 1319  
 Film Movie **▶** 279



22 0526

PKD-bestückte Vollhartmetall-Hochleistungsbohrer Vierfasenbohrer  
Solid carbide four-phase drill with PCD tips

Aluminium > 6% Si	<b>DURO-PLASTE</b> DURO-PLASTICS
Aluminium < 6% Si	<b>Aramid fiber</b> AFK-SFK
Aluminium	<b>Hybridstoffe</b> hybrid materials
MESSING brass	<b>CFK-ALU</b> Composite <b>CFRP-ALU</b> Composites
Kupfer copper	<b>GRAPHIT</b> graphite
GFK-CFK GFRP-CFRP	<b>NE METALLE</b> non-ferrous
<b>THERMO-PLAST</b> THERMO-PLASTICS	

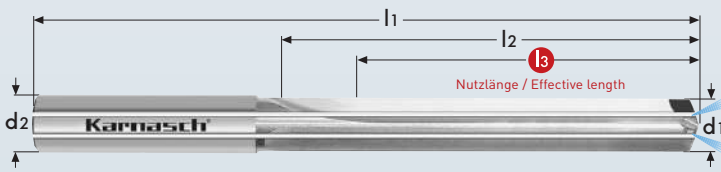

<b>PKD PCD</b> MICRO-GRAIN	<b>DIN 6537</b>
<b>SPEZIAL</b> SPECIAL	<b>DIN 6535</b> Form HAK
	<b>HSC</b> High-Speed-Cutting
	<b>GELÄPPT</b> LAPPED

Art.	d1 H7	l3	l2	l1	d2 $\begin{smallmatrix} -0,002 \\ +0,005 \end{smallmatrix}$	€
22 0526 0800 094	8,0	94	108	146	8,0	349,80
22 0526 1000 080	10,0	80	95	142	10,0	353,11
22 0526 1000 110	10,0	110	120	162	10,0	445,20
22 0526 1200 056	12,0	56	71	118	12,0	321,31
22 0526 1200 096	12,0	96	114	162	12,0	483,60
22 0526 1200 142	12,0	142	156	204	12,0	616,80

% Sonderpreis / Sale Artikel. Lieferbar solange Vorrat.  
Special price / sale article. While stocks last.

Schnittdaten  
Cutting data

1254

Diamantbestückte Qualitätsprodukte.  
Diamond tipped quality products.

**Karnasch®**  
PROFESSIONAL TOOLS

## DIAMOND TOOLS

Diamond tools



CBN



PKD  
PCD



Naturdiamant  
Natural Diamond  
ND



Monokristallin Diamant  
Monocrystalline  
diamond MCD



CVD /  
Diamant Beschichtung  
Diamond coating

PKD/PCD **EXTREME**

# High-Precision-Werkzeuge aus dem Hause Karnasch

## High-Precision-Tools from Karnasch



Metallverarbeitende Unternehmen brauchen die absolute Gewissheit, mit hochwertigen, leistungsstarken und prozesssicheren Werkzeugen zu arbeiten. Karnasch Professional Tools bietet das, worauf es ankommt!

Wir sind ein weltweit agierendes Unternehmen mit Hauptsitz im badischen Heddeshheim sowie in Görsdorf (Brandenburg), das

- Hochleistungswerkzeuge zur Metallverarbeitung von herausragender Qualität produziert und vertreibt,
- seit 1961 auf dem Markt tätig ist und dementsprechend über große Erfahrung, umfassendes Know-how sowie überdurchschnittliche Kundenorientierung verfügt,
- durch intelligente Lagerhaltung jederzeit die sofortige Lieferbarkeit seiner Produkte garantiert,
- in vielen Regionen der Welt Vertriebspartner hat, damit auch für Ihre Auslandsniederlassungen eine permanente Versorgung und begleitender Service gewährleistet ist,
- Support groß schreibt und diesen Anspruch u.a. durch eine Service-Hotline auch erfüllt,
- mit der Eröffnung einer Niederlassung in Görsdorf (Brandenburg) bereits im Jahr 1992 auf gesamtdeutsche Präsenz gesetzt hat.

Weltweit zählen Kunden aus folgenden Bereichen auf Karnasch Professional Tools:

- Werkzeug- und Formenbau,
- Luft- und Raumfahrt,
- Automobilindustrie,
- Schiff- und Eisenbahnbau,
- Hoch-, Stahl- und Brückenbau,
- Dental.

Metal working companies require absolute certainty to work with high-quality, high-performance and reliable tools. Karnasch Professional Tools offers all that matters!

We are a family-run business that is actively involved on a worldwide scale, with our head office in Heddeshheim in Baden and Görsdorf (Brandenburg), which

- produces and distributes excellent quality, high performance tools for metal working,
- has been active in the market since 1961 and has accordingly obtained invaluable experience, comprehensive know-how and above average customer orientation,
- guarantees immediate availability of our products at any time thanks to intelligent stock-keeping,
- has sales partners in many regions of the world, and can thus also ensure a continuous and accompanying service for your overseas branches.
- places an emphasis on support and fulfils this claim via, amongst other things, a service hotline.
- cemented our presence throughout Germany with the opening of a branch in Görsdorf (Brandenburg) in 1992.

Our customers predominantly come from the following sectors:

- Tool and mould making,
- Aviation and astronautics,
- The automotive industry,
- Shipbuilding and railway construction,
- Structural engineering, steel construction and bridge building,
- Dental.



Weitere Informationen zu unserer kompletten Produktpalette erhalten Sie auch im Internet unter:

[WWW.KARNASCH.TOOLS](http://WWW.KARNASCH.TOOLS)



Index



## 22 2025

Vollhartmetall-Maschinengewindebohrer 50 - 63 HRC, < 1,5xD  
Solid carbide machine taps, metric 50 - 63 HRC

**HRC 50-63**

**GJL**

**GJS**

**GTW GTS**

**GRAPHIT graphite**

**kurz-spanend short chip**

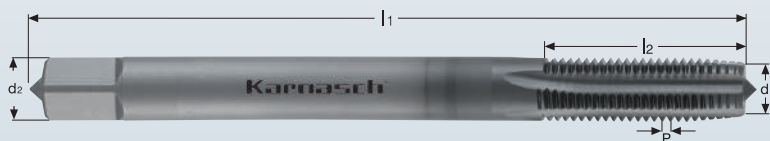

**Bearbeitungshinweis:** Verwenden Sie ausschließlich Schneidpaste mit Hochdruckzusätzen wie Karnasch Art.-Nr. 60 1157 + 60 1159. Alternativ geeignetes Schneidöl, keine Emulsion.

**Machining indication:** Please use exclusively our cutting paste with the extreme pressure additive Karnasch art.-no. 60 1157 + 60 1159. Alternative suitable cutting oil, no emulsion.

**Richtwerte für den Einsatz von VHM-Maschinengewindebohrern 50 - 63 HRC**  
Recommended cutting data for Micro Grain Maschine Taps 50 - 63 HRC

50 - 54 HRC Vc = 4 - 6 m/min	55 - 59 HRC Vc = 3 - 5 m/min	60 - 63 HRC Vc = 2 - 4 m/min
---------------------------------	---------------------------------	---------------------------------

Vorausgesetzt werden stabile Maschinenverhältnisse. Wir empfehlen Synchronspindel. Keinesfalls von Hand schneiden. Prerequisite are stabil machines. Absolutely no manual use. We recommend Syncronspindl. Only with machine.

**MICRO GRAIN**

**DIN 371 376**

**M**

**ISO 2 6HX**

**50-63 HRC**

**4-5 x P**  
**Form D**



**HHC**



**XXM-1**



Art.	d1 Gewinde	P	l1	l2	d2 h6	k	Ø	€
22 2025 03	• M 3	0,5	56	14	3,5	2,7	2,6	193,00
22 2025 04	• M 4	0,7	63	14	4,5	3,4	3,5	197,00
22 2025 05	• M 5	0,8	70	20	6,0	4,9	4,4	205,00
22 2025 06	• M 6	1,0	80	24	6,0	4,9	5,3	201,00
22 2025 08	• M 8	1,25	90	24	8,0	6,2	7,1	216,00
22 2025 10	• M 10	1,5	100	26	10,0	8,0	8,8	249,00

## 22 2215

Vollhartmetall-Maschinengewindebohrer Feingewinde 50 - 63 HRC, < 1,5xD  
Solid carbide machine taps, metric fine thread 50 - 63 HRC

**HRC 50-63**

**GJL**

**GJS**

**GTW GTS**

**GRAPHIT graphite**

**kurz-spanend short chip**

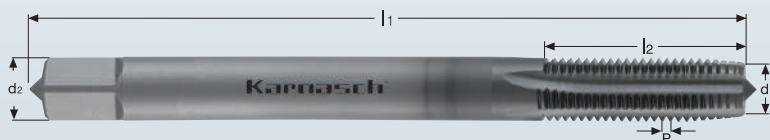
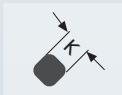

**Bearbeitungshinweis:** Verwenden Sie ausschließlich Schneidpaste mit Hochdruckzusätzen wie Karnasch Art.-Nr. 60 1157 + 60 1159. Alternativ geeignetes Schneidöl, keine Emulsion.

**Machining indication:** Please use exclusively our cutting paste with the extreme pressure additive Karnasch art.-no. 60 1157 + 60 1159. Alternative suitable cutting oil, no emulsion.

**Richtwerte für den Einsatz von VHM-Maschinengewindebohrern 50 - 63 HRC**  
Recommended cutting data for Micro Grain Maschine Taps 50 - 63 HRC

50 - 54 HRC Vc = 4 - 6 m/min	55 - 59 HRC Vc = 3 - 5 m/min	60 - 63 HRC Vc = 2 - 4 m/min
---------------------------------	---------------------------------	---------------------------------

Vorausgesetzt werden stabile Maschinenverhältnisse. Wir empfehlen Synchronspindel. Keinesfalls von Hand schneiden. Prerequisite are stabil machines. Absolutely no manual use. We recommend Syncronspindl. Only with machine.

**MICRO GRAIN**

**DIN 371 376**

**MF**

**ISO 2 6HX**

**50-63 HRC**

**4,5 - P**  
**Form B**



**HHC**



**XXM-1**



Art.	d1 Gewinde	P	l1	l2	d2	k	Ø	€
22 2215 1215	% M 12	1,5	100	18	9	7,0	10,8	390,00

% Sonderpreis / Sale Artikel. Lieferbar solange Vorrat. Special price / sale article. While stocks last.

Vollhartmetall-Whitworth Rohrgewinde-Gewindebohrer 50 - 63 HRC, < 1,5xD  
Solid carbide Whitworth screw tap 50 - 63 HRC

22 2239

- HRC 50-63**
- GJL**
- GJS**
- GTW GTS**
- GRAPHIT graphite**
- kurz-spanend short chip**



**Bearbeitungshinweis:** Verwenden Sie ausschließlich Schneidpaste mit Hochdruckzusätzen wie Karnasch Art.-Nr. 60 1157 + 60 1159. Alternativ geeignetes Schneidöl, keine Emulsion.

**Machining indication:** Please use exclusively our cutting paste with the extreme pressure additive Karnasch art.-no. 60 1157 + 60 1159. Alternative suitable cutting oil, no emulsion.

**Richtwerte für den Einsatz von VHM-Maschinengewindebohrern 50 - 63 HRC**  
Recommended cutting data for Micro Grain Maschine Taps 50 - 63 HRC

50 - 54 HRC Vc = 4 - 6 m/min	55 - 59 HRC Vc = 3 - 5 m/min	60 - 63 HRC Vc = 2 - 4 m/min
---------------------------------	---------------------------------	---------------------------------

Vorausgesetzt werden stabile Maschinenverhältnisse. Wir empfehlen Synchronspindel. Keinesfalls von Hand schneiden. Prerequisite are stabil machines. Absolutely no manual use. We recommend Synchronspindl. Only with machine.

<b>MICRO GRAIN</b>	<b>DIN 5156</b>
<b>G</b>	<b>ISO 228/BSP</b>
<b>HRC 50-63</b>	<b>4-5 x P Form D</b>
	<b>HHC</b>
	<b>XXM-1</b>

Art.	d1 Gewinde	P	l1	l2	d2/h6	k		€
22 2239 1/8	<b>% G 1/8</b>	28	90	24	7	5,5	8,8	<b>337,20</b>

**%** Sonderpreis / Sale Artikel. Lieferbar solange Vorrat. Special price / sale article. While stocks last.

Schmierstoffe & Schneidöl  
Lubricant & Cutting oil

60 1159 60 1157

**125 g**  
**Universal-SCHNEIDPASTE**  
Universal cutting paste  
**chlorfrei / silikonfrei**  
chlorine free / silicone free

60 1159

**750 g**  
**Universal-SCHNEIDPASTE**  
Universal cutting-paste  
**chlorfrei / silikonfrei**  
chlorine free / silicone free

60 1157

- Paste haftet am Werkzeug.
- Kein Tropfen und Umherspritzen.

Ideal zum Arbeiten in Zwangslagen wie z.B. „Überkopfeinsatz“ und bei Maschinen ohne Kühlmittleinrichtung.

**Verwendung:** Erhöht signifikant die Standzeiten und Oberflächengüte beim: Sägen, Fräsen, Gewindeschneiden, Reiben, Bohren, Drehen.

Zum Zerspanen aller Stähle sowie schwierigster Materialien wie Titan-, Mangan-, Stahlguss-, Chrom-Nickel oder Molybdän-Stählen.

Hervorragend auch für alle Nichteisenmetalle wie Alu, Kupfer, Messing.

- The paste sticks to the tool.
- No dripping or splashing

Ideal for working under difficult circumstances e.g. "Overhead use" and for machines without cooling device.

**Application:** Increases tool life and surface finish significantly when: sawing, milling, tapping, grinding, drilling.

For machining all kind of steels. Also excellent for extremely difficult materials such as titanium-, manganese-, cast steel-, chrome-nickel or molybdenum steels.

Also excellent for all non-ferrous metals such as aluminum, copper, brass.

Art.	g/Dose	Stück/piece	€
60 1159	• 125 g	1	6,95

Art.	g/Dose	Stück/piece	€
60 1157	• 750 g	1	25,45

- 1
- 2
- 3
- 4
- 5
- 6
- 7
- 8
- 9

Index

## 29 0060

PKD-Vollhartmetall-Micro-Hochleistungsbohrer  
PCD equipped solid carbide high performance micro drill



<b>PKD PCD</b>	KARNASCH NORM
<b>SPEZIAL SPECIAL</b>	DIN 6535 Form HA
	25° 130°
	<b>HSC</b> High-Speed-Cutting
	<b>POLIERT POLISHED</b>
	OIL Emul MMKS

<b>COMPO-SITES</b>	<b>Sand-wich</b>
Aramid fiber AFK-SFK	<b>GF GF25</b>
<b>Hybrid-stoffe</b> hybrid materials	<b>PVDF GF25</b>
CFK-ALU Composite CFRP-ALU Composites	<b>GFK GFRP</b>
Schicht-stoffe Laminates	<b>CFK CFRP</b>
<b>Kevlar</b>	<b>PMMA GS</b>
<b>PA66 GF30</b>	Aluminium < 12% Si
<b>PVDF GF30</b>	Aluminium > 12% Si
<b>PEEK GF30</b>	<b>GRAPHIT</b> graphite
<b>PEEK CF30</b>	<b>ZIRKON OXID</b> ZIRCONIA

Art.	d1 h7	l3	l2	l1	d2 h5	€
29 0060 0080 080	0,80	8	9	38	3	193,20
29 0060 0090 080	0,90	8	9	38	3	193,20
29 0060 0110 090	1,10	9	10	38	3	193,20
29 0060 0120 090	1,20	9	10	38	3	201,60
29 0060 0130 080	1,30	8	10	38	3	201,60

% Sonderpreis / Sale Artikel. Lieferbar solange Vorrat.  
Special price / sale article. While stocks last.

## 22 0415

Diamantbeschichtete VHM-Hochleistungsbohrer mit Innenkühlung geeignet für  
Gewindefräser Art. 23 2005 / 23 2006

Diamond coated solid carbide high performance twist drill with internal cooling,  
suitable for thread milling cutter article 23 2005 / 23 2006

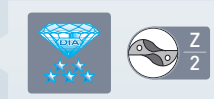
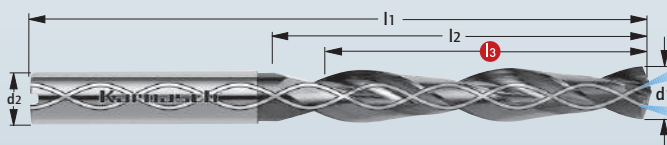

<b>DIAMANT DIAMOND</b>	<b>DIN 6537</b>
<b>W</b>	DIN 6535 Form HA
	30° 130°
	<b>HSC HPC</b>
	<b>DIAMANT DIAMOND DCC 0312</b>
	Air

Richtwerte für den Einsatz von Karnasch diamantbeschichtete Hochleistungsbohrer  
Recommended cutting data for twist drill with diamond coating

Werkstoffgruppe Material group	Werkstoff Workpiece material	Schnittgeschwindigkeit Vc (m/min.)	VORSCHUB PRO UMDREHUNG (mm)		
			Ø 3,0 - 5,0	Ø 5,1 - 8,0	Ø 8,1 - 12,0
14	Graphit < Grad 10	250	0,10 - 0,20	0,15 - 0,25	0,30 - 0,45

Art.	d1 m7	l3	l2	l1	d2 h6	€
22 0415 0330 023	3,3 / M4 × 0,7	23	28	66	6	51,60
22 0415 0680 043	6,8 / M8 × 1,25	43	53	91	8	73,80
22 0415 0850 049	8,5 / M10 × 1,50	49	61	103	10	85,20
22 0415 1030 056	10,3 / M12 × 1,75	56	71	118	12	111,00

% Sonderpreis / Sale Artikel. Lieferbar solange Vorrat.  
Special price / sale article. While stocks last.

Nachfolgewerkzeug / Replacement article 29 0120 + 29 0121 + 29 0122 auf Seite / on page 288-291

Schnittdaten  
Cutting data

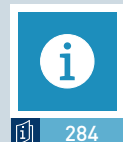

Diamantbeschichteter Vollhartmetall Gewindefräser, spiralisiert 30° für Innengewinde ohne Innenkühlung, ohne Senkstufe, metrisches ISO-Gewinde DIN 13 – 2,5xD

23 2005

Diamond coated solid carbide thread milling cutter, 30° spiral for internal threads, without internal cooling and without counter sunk stage, metric ISO-thread DIN 13 – 2,5xD

<b>COMPO-SITES</b>	<b>TI-CFK</b> TI-CFRP
<b>GRAPHIT</b> graphite	<b>PA66</b> GF30
<b>GFK</b> GFRP	<b>PVDF</b> GF30
<b>CFK</b> CFRP	<b>PEEK</b> GF30
<b>Hybridstoffe</b> hybrid materials	<b>PEEK</b> CF30
<b>CFK-ALU</b> Composite <b>CFRP-ALU</b> Composites	<b>ZIRKON OXID</b> ZIRCONIA
<b>Schichtstoffe</b> Laminates	



<b>DIAMANT DIAMOND</b>	<b>DIN 13</b>
<b>M</b>	<b>DIN 6535</b> Form HA
	<b>HSC</b> High-Speed-Cutting
	<b>DCC 0318</b>

Art.	M	Stg	x D	l2	l1	d1	d2 h5	Z	€
23 2005 04 070 25	• M 4	0,7	2,5xD	10,85	55	3,15	6	3	163,00
23 2005 05 080 25	• M 5	0,8	2,5xD	13,15	55	4,00	6	3	166,00
23 2005 06 100 25	• M 6	1,0	2,5xD	16,50	55	4,80	6	3	172,00
23 2005 08 125 25	• M 8	1,25	2,5xD	21,80	55	6,00	6	3	183,00
23 2005 10 150 25	• M 10	1,50	2,5xD	26,20	65	8,00	8	3	218,00
23 2005 12 175 25	• M 12	1,75	2,5xD	30,60	75	9,90	10	4	257,00

PKD - CVD Gewindefräser kurzfristig lieferbar!

Schnittdaten Cutting data 1271

Zeichnungen Drawings DXF/STEP

Diamantbeschichteter Vollhartmetall-Gewindefräser, spiralisiert für Innengewinde ohne Innenkühlung, mit 90° Senkstufe, metrisches ISO-Gewinde DIN 13 – 2,0xD

23 2006

Diamond coated solid carbide thread milling cutter, 30° spiral for internal threads, without internal cooling with 90° counter sunk stage, metric ISO-thread DIN 13 – 2,0xD

<b>COMPO-SITES</b>	<b>TI-CFK</b> TI-CFRP
<b>GRAPHIT</b> graphite	<b>PA66</b> GF30
<b>GFK</b> GFRP	<b>PVDF</b> GF30
<b>CFK</b> CFRP	<b>PEEK</b> GF30
<b>Hybridstoffe</b> hybrid materials	<b>PEEK</b> CF30
<b>CFK-ALU</b> Composite <b>CFRP-ALU</b> Composites	<b>ZIRKON OXID</b> ZIRCONIA
<b>Schichtstoffe</b> Laminates	

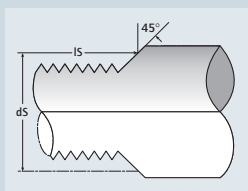
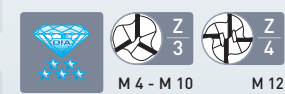
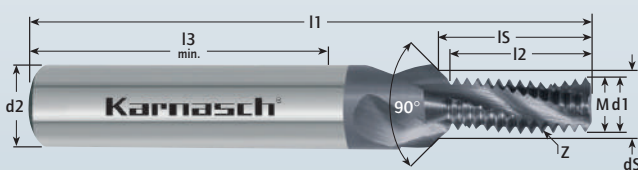

<b>DIAMANT DIAMOND</b>	<b>DIN 13</b>
<b>M</b>	<b>DIN 6535</b> Form HA
	<b>HSC</b> High-Speed-Cutting
	<b>DCC 0318</b>

Art.	M	Stg	x D	l2	l3/min.	l1	ds	ls	d1	d2 h5	Z	€
23 2006 04 070 20	• M 4	0,7	2,0xD	8,75	36	55	4,2	9,3	3,14	6	3	169,00
23 2006 05 080 20	• M 5	0,8	2,0xD	10,75	36	55	5,3	11,3	4,00	6	3	177,00
23 2006 06 100 20	• M 6	1,0	2,0xD	12,40	36	65	6,3	13,1	4,80	8	3	194,00
23 2006 08 125 20	• M 8	1,25	2,0xD	16,80	40	75	8,3	17,6	6,50	10	3	236,00
23 2006 10 150 20	• M 10	1,50	2,0xD	20,10	45	80	10,3	21,2	8,20	12	3	319,00
23 2006 12 175 20	• M 12	1,75	2,0xD	25,20	45	90	12,3	26,4	9,90	14	4	370,00

PKD - CVD Gewindefräser kurzfristig lieferbar!

Schnittdaten Cutting data 1271

Zeichnungen Drawings DXF/STEP

## 29 0080 A

## 29 0080 B

Vollhartmetall-Hochleistungsbohrer GFK/CFK  
Solid carbide twist drill GFK/CFK

<b>COMPOSITES</b>	CFK-ALU Composite CFRP-ALU Composites	PVDF GF30
GFK-CFK GFRP-CFRP	Schichtstoffe Laminates	PEEK GF30
THERMOPLAST THERMOPLASTICS	Kevlar	PEEK CF30
DUROPLASTE DUROPLASTICS	AL/TI	GF GF25
Aramid fiber AFK-SFK	TI-CFK TI-CFRP	PVDF GF25
Hybridstoffe hybrid materials	PA66 GF30	

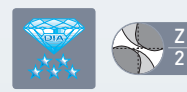
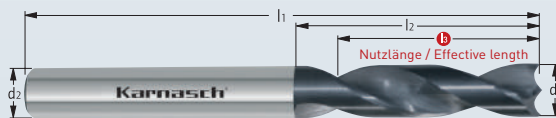

<b>MICRO GRAIN</b>	KARNASCH NORM
<b>SPEZIAL</b> SPECIAL	Form HA
	<b>HSC</b> High-Speed-Cutting
	<b>DCA-06</b> Polished

GFK-CFK GFRP-CFRP	CFK-ALU Composite CFRP-ALU Composites	Kevlar
Kunststoff plastic	Schichtstoffe Laminates	Plexiglas acrylic glass

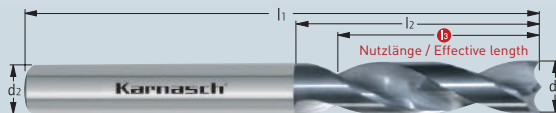

Schnittdaten  
Cutting data

Zeichnungen  
Drawings



d1 <sup>⊕</sup>	l3	l2	l1	d2h5	Art.	DIAMANT DIAMOND DCA-06		POLIERT POLISHED	
						29 0080 A		29 0080 B	
						€	Art.	€	
• 3,0	12	16	45	3,0	29 0080A 0300 012	48,00	29 0080B 0300 012	27,00	
• 3,2	14	18	50	3,2	29 0080A 0320 014	61,00	29 0080B 0320 014	27,00	
• 3,3	14	18	50	3,2	-	-	29 0080B 0330 014	27,00	
• 3,5	15	20	50	3,5	29 0080A 0350 015	61,00	29 0080B 0350 015	27,00	
• 3,7	15	20	52	3,7	-	-	29 0080B 0370 015	27,00	
• 4,0	17	22	55	4,0	29 0080A 0400 017	61,00	29 0080B 0400 017	27,00	
• 4,2	17	22	55	4,2	-	-	29 0080B 0420 017	32,00	
• 4,5	18	25	57	4,5	29 0080A 0450 018	80,00	29 0080B 0450 018	32,00	
• 4,7	18	24	58	4,7	-	-	29 0080B 0470 018	39,00	
• 5,0	20	25	62	5,0	29 0080A 0500 020	87,00	29 0080B 0500 020	39,00	
• 5,3	20	26	62	5,3	-	-	29 0080B 0530 020	39,00	
• 5,5	20	28	65	5,5	29 0080A 0550 020	94,00	29 0080B 0550 020	46,00	
• 5,8	20	28	66	5,8	-	-	29 0080B 0580 020	46,00	
• 6,0	20	28	65	6,0	29 0080A 0600 020	94,00	29 0080B 0600 020	46,00	
• 6,5	22	30	70	6,5	29 0080A 0650 022	116,00	29 0080B 0650 022	50,00	
• 7,0	25	33	75	7,0	29 0080A 0700 025	122,00	29 0080B 0700 025	56,00	
• 7,5	25	33	74	7,5	-	-	29 0080B 0750 025	56,00	
• 8,0	27	36	80	8,0	29 0080A 0800 027	133,00	29 0080B 0800 027	67,00	
• 8,5	27	36	80	8,5	29 0080A 0850 027	149,00	29 0080B 0850 027	74,00	
• 9,0	30	40	85	9,0	29 0080A 0900 030	154,00	29 0080B 0900 030	78,00	
• 9,5	30	37	84	9,5	-	-	29 0080B 0950 030	86,00	
• 10,0	32	42	90	10,0	29 0080A 1000 032	166,00	29 0080B 1000 032	90,00	
• 10,5	32	42	90	10,5	-	-	29 0080B 1050 032	102,00	
• 11,0	34	47	95	11,0	-	-	29 0080B 1100 034	116,00	
• 11,5	34	47	95	11,5	-	-	29 0080B 1150 034	129,00	
• 12,0	35	50	100	12,0	29 0080A 1200 035	216,00	29 0080B 1200 035	129,00	
• 13,0	35	50	100	13,0	-	-	29 0080B 1300 035	129,00	
• 14,0	37	54	105	14,0	-	-	29 0080B 1400 037	129,00	
• 15,0	38	56	110	15,0	-	-	29 0080B 1500 038	129,00	
• 16,0	38	58	115	16,0	-	-	29 0080B 1600 038	129,00	

d1 tol. <sup>⊕</sup>	29 0080 A		29 0080 B	
	Bohrertoleranz Drill tolerance	Bohrertoleranz Drill tolerance	Bohrertoleranz Drill tolerance	Bohrertoleranz Drill tolerance
> 3,0	+ 0,005		+ 0,000	
6,0	- 0,008		- 0,012	
> 6,0	+ 0,005		+ 0,000	
10,0	- 0,010		- 0,015	
> 10,0	+ 0,005		+ 0,000	
14,0	- 0,012		- 0,018	

**CFK-Bohrertest**  
CFK drill test



**Karnasch Art. 29 0120 – 6,0 mm**  
Bohrungseintritt / drill entry  
Material: CFK / CFRP

Schnittdaten / cutting data  
Vc = 160 m/min  
Vf = 850 mm/min  
n(s) = 8493 min<sup>-1</sup>  
fz = 0,1 mm  
ap = 20 mm



**Karnasch Art. 29 0120 – 6,0 mm**  
Bohrungsausritt / drill exit  
Material: CFK / CFRP

Vergrößerung / Magnification: 30x



**CVD Bohrer 6,0 mm**  
Mitbewerber / competitor  
Bohrungseintritt / drill entry  
Material: CFK / CFRP

Schnittdaten / cutting data  
Vc = 160 m/min  
Vf = 850 mm/min  
n(s) = 8493 min<sup>-1</sup>  
fz = 0,1 mm  
ap = 20 mm



**CVD Bohrer 6,0 mm**  
Mitbewerber / competitor  
Bohrungsausritt / drill exit  
Material: CFK / CFRP

Vergrößerung / Magnification: 30x



**Karnasch®**  
PROFESSIONAL TOOLS

1



2



3



4



5



6



7



8



9



29 0120

Diamantbeschichtete VHM-Hochleistungsbohrer für CFK/GFK – multidirektional – mit 90° Spitzwinkel vermeidet Delamination  
 Diamond-coated solid-carbide drill for CFRP/GFRP – multidirectional – with 90° tip angle, prevents delamination

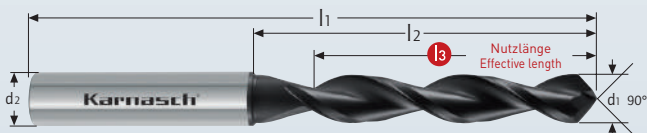

<b>MICRO GRAIN</b>	KARNASCH NORM
<b>MF</b>	DIN 6535 Form HA
	Composites
	DCC 0318
	Air

### Empfohlene Schnittdaten / Recommended cutting data

Werkstoffgruppe Material group	WERKSTOFF WORKPIECE MATERIAL	vc m/min	f mm/U				
			Ø <3	Ø 3,0 - 4,9	Ø 5,0 - 7,9	Ø 8,0 - 9,9	Ø 10,0 - 12,0
8.3	GFK / CFK Composites	160	0,02 - 0,03	0,04	0,05	0,07	0,1

Art.	d1 m7	l3	l2	l1	d2 h6	€
29 0120 0050 0045	0,5	4,5	5,5	55	3	67,00
29 0120 0060 0045	0,6	4,5	5,5	55	3	67,00
29 0120 0070 0045	0,7	4,5	5,5	55	3	67,00
29 0120 0080 0045	0,8	4,5	5,5	55	3	67,00
29 0120 0090 0045	0,9	4,5	5,5	55	3	67,00
29 0120 0100 005	1,0	5	8	55	3	67,00
29 0120 0110 008	1,1	8	12	55	3	67,00
29 0120 0120 008	1,2	8	12	55	3	67,00
29 0120 0130 008	1,3	8	12	55	3	67,00
29 0120 0140 008	1,4	8	12	55	3	67,00
29 0120 0150 008	1,5	8	12	55	3	67,00
29 0120 0160 011	1,6	11	16	68	3	71,00
29 0120 0170 011	1,7	11	16	68	3	71,00
29 0120 0180 011	1,8	11	16	68	3	71,00
29 0120 0190 011	1,9	11	16	68	3	71,00
29 0120 0200 011	2,0	11	16	68	3	71,00
29 0120 0210 014	2,1	14	20	74	3	73,00
29 0120 0220 014	2,2	14	20	74	3	73,00
29 0120 0230 014	2,3	14	20	74	3	73,00
29 0120 0240 014	2,4	14	20	74	3	73,00
29 0120 0250 014	2,5	14	20	74	3	73,00
29 0120 0260 016	2,6	16	23	81	3	75,00
29 0120 0270 016	2,7	16	23	81	3	75,00
29 0120 0280 016	2,8	16	23	81	3	75,00
29 0120 0290 016	2,9	16	23	81	3	75,00
29 0120 0300 023	3,0	23	28	66	6	123,00
29 0120 0310 023	3,1	23	28	66	6	123,00
29 0120 03175 023	3,175	23	28	66	6	123,00
29 0120 0320 023	3,2	23	28	66	6	123,00
29 0120 0330 023	3,3	23	28	66	6	123,00
29 0120 0340 023	3,4	23	28	66	6	123,00
29 0120 0350 023	3,5	23	28	66	6	123,00
29 0120 0360 023	3,6	23	28	66	6	123,00
29 0120 0370 023	3,7	23	28	66	6	123,00
29 0120 0380 023	3,8	23	28	66	6	123,00
29 0120 0390 023	3,9	23	28	66	6	123,00
29 0120 0400 029	4,0	29	36	74	6	129,00
29 0120 0410 029	4,1	29	36	74	6	129,00
29 0120 0420 029	4,2	29	36	74	6	129,00
29 0120 0430 029	4,3	29	36	74	6	129,00
29 0120 0440 029	4,4	29	36	74	6	129,00
29 0120 0450 029	4,5	29	36	74	6	129,00
29 0120 0460 029	4,6	29	36	74	6	129,00
29 0120 0470 029	4,7	29	36	74	6	129,00
29 0120 04763 029	4,763	29	36	74	6	129,00
29 0120 0480 029	4,8	29	36	74	6	129,00
29 0120 0490 029	4,9	29	36	74	6	129,00
29 0120 0500 035	5,0	35	44	82	6	129,00
29 0120 0510 035	5,1	35	44	82	6	129,00
29 0120 0520 035	5,2	35	44	82	6	129,00
29 0120 0530 035	5,3	35	44	82	6	129,00
29 0120 0540 035	5,4	35	44	82	6	129,00
29 0120 0550 035	5,5	35	44	82	6	129,00
29 0120 0560 035	5,6	35	44	82	6	129,00
29 0120 0570 035	5,7	35	44	82	6	129,00
29 0120 0580 035	5,8	35	44	82	6	129,00
29 0120 0590 035	5,9	35	44	82	6	129,00

Schnittdaten Cutting data	Film Movie	Zeichnungen Drawings
288		DXF/STEP

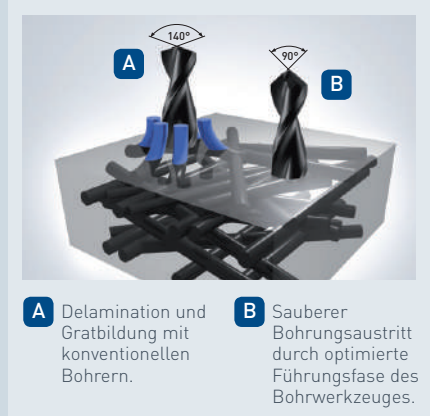

Diamantbeschichtete VHM-Hochleistungsbohrer für CFK/GFK – multidirektional – mit 90° Spitzwinkel vermeidet Delamination  
 Diamond-coated solid-carbide drill for CFRP/GFRP – multidirectional – with 90° tip angle, prevents delamination

29 0120

Art.	d1 m7	l3	l2	l1	d2 h6	€
29 0120 0600 035	• 6,0	35	44	82	6	129,00
29 0120 0610 043	• 6,1	43	53	91	8	195,00
29 0120 0620 043	• 6,2	43	53	91	8	195,00
29 0120 0630 043	• 6,3	43	53	91	8	195,00
29 0120 0635 043	• 6,350	43	53	91	8	195,00
29 0120 0640 043	• 6,4	43	53	91	8	195,00
29 0120 0650 043	• 6,5	43	53	91	8	195,00
29 0120 0660 043	• 6,6	43	53	91	8	195,00
29 0120 0670 043	• 6,7	43	53	91	8	195,00
29 0120 0680 043	• 6,8	43	53	91	8	195,00
29 0120 0690 043	• 6,9	43	53	91	8	195,00
29 0120 0700 043	• 7,0	43	53	91	8	195,00
29 0120 0710 043	• 7,1	43	53	91	8	195,00
29 0120 0720 043	• 7,2	43	53	91	8	195,00
29 0120 0730 043	• 7,3	43	53	91	8	195,00
29 0120 0740 043	• 7,4	43	53	91	8	195,00
29 0120 0750 043	• 7,5	43	53	91	8	195,00
29 0120 0760 043	• 7,6	43	53	91	8	195,00
29 0120 0770 043	• 7,7	43	53	91	8	195,00
29 0120 0780 043	• 7,8	43	53	91	8	195,00
29 0120 0790 043	• 7,9	43	53	91	8	195,00
29 0120 07938 043	• 7,938	43	53	91	8	195,00
29 0120 0800 043	• 8,0	43	53	91	8	195,00
29 0120 0810 049	• 8,1	49	61	103	10	231,00
29 0120 0820 049	• 8,2	49	61	103	10	231,00
29 0120 0830 049	• 8,3	49	61	103	10	231,00
29 0120 0840 049	• 8,4	49	61	103	10	231,00
29 0120 0850 049	• 8,5	49	61	103	10	231,00
29 0120 0860 049	• 8,6	49	61	103	10	231,00
29 0120 0870 049	• 8,7	49	61	103	10	231,00
29 0120 0880 049	• 8,8	49	61	103	10	231,00
29 0120 0890 049	• 8,9	49	61	103	10	231,00
29 0120 0900 049	• 9,0	49	61	103	10	231,00
29 0120 0910 049	• 9,1	49	61	103	10	231,00
29 0120 0920 049	• 9,2	49	61	103	10	231,00
29 0120 0930 049	• 9,3	49	61	103	10	231,00
29 0120 0940 049	• 9,4	49	61	103	10	231,00
29 0120 0950 049	• 9,5	49	61	103	10	231,00
29 0120 09525 049	• 9,525	49	61	103	10	231,00
29 0120 0960 049	• 9,6	49	61	103	10	231,00
29 0120 0970 049	• 9,7	49	61	103	10	231,00
29 0120 0980 049	• 9,8	49	61	103	10	231,00
29 0120 0990 049	• 9,9	49	61	103	10	231,00
29 0120 1000 049	• 10,0	49	61	103	10	231,00
29 0120 1010 056	• 10,1	56	71	118	12	251,00
29 0120 1020 056	• 10,2	56	71	118	12	251,00
29 0120 1030 056	• 10,3	56	71	118	12	251,00
29 0120 1040 056	• 10,4	56	71	118	12	251,00
29 0120 1050 056	• 10,5	56	71	118	12	251,00
29 0120 1060 056	• 10,6	56	71	118	12	251,00
29 0120 1070 056	• 10,7	56	71	118	12	251,00
29 0120 1080 056	• 10,8	56	71	118	12	251,00
29 0120 1090 056	• 10,9	56	71	118	12	251,00
29 0120 1100 056	• 11,0	56	71	118	12	251,00
29 0120 11111 056	• 11,111	56	71	118	12	251,00
29 0120 1200 056	• 12,0	56	71	118	12	251,00

Material: CFK/CFRP Multidirectional  
 Bohrer/Drill: 29 0120 Ø 8 mm

**Karnasch®**  
 PROFESSIONAL TOOLS





29 0121

Diamantbeschichtete VHM-Hochleistungsbohrer für CFK/GFK – unidirektional – mit 90° Spitzwinkel vermeidet Delamination

Diamond-coated solid-carbide drill for CFRP/GFRP – unidirectional – with 90° tip angle, prevents delamination

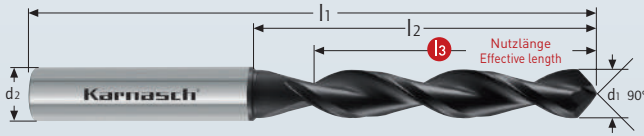

### Empfohlene Schnittdaten / Recommended cutting data

Werkstoffgruppe Material group	WERKSTOFF WORKPIECE MATERIAL	vc m/min	f mm/U			
			Ø 2,8 - 4,9	Ø 5,0 - 7,9	Ø 8,0 - 9,9	Ø 10,0 - 12,0
8.3	GFK / CFK Composites	160	0,04	0,05	0,07	0,1



UNIDIREKTIONAL  
Faserverlauf in eine Richtung  
Fibre progress in one direction

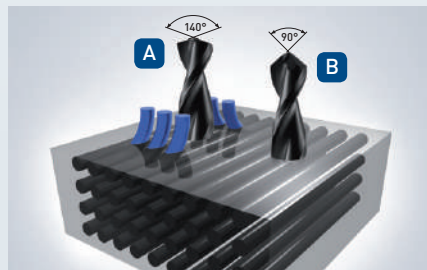

**A** Delamination und Gratbildung mit konventionellen Bohrern.  
**B** Sauberer Bohrungsaustritt durch optimierte Führungsfase des Bohrwerkzeuges.

<b>MICRO GRAIN</b>	KARNASCH NORM
<b>MF</b>	DIN 6535 Form HA
	Composites
	DCC 0318
	Air

Schnittdaten Cutting data	Zeichnungen Drawings
290	DXF/STEP

Art.	d1 m7	l3	l2	l1	d2 h6	€
29 0121 0280 019	• 2,8	19	24	66	6	171,00
29 0121 0290 019	• 2,9	19	24	66	6	171,00
29 0121 0300 023	• 3,0	23	28	66	6	171,00
29 0121 0310 023	• 3,1	23	28	66	6	171,00
29 0121 03175 023	• 3,175	23	28	66	6	174,00
29 0121 0320 023	• 3,2	23	28	66	6	171,00
29 0121 0330 023	• 3,3	23	28	66	6	171,00
29 0121 0340 023	• 3,4	23	28	66	6	171,00
29 0121 0350 023	• 3,5	23	28	66	6	171,00
29 0121 0360 023	• 3,6	23	28	66	6	171,00
29 0121 0370 023	• 3,7	23	28	66	6	171,00
29 0121 0380 023	• 3,8	23	28	66	6	171,00
29 0121 0390 023	• 3,9	23	28	66	6	171,00
29 0121 0400 029	• 4,0	29	36	74	6	174,00
29 0121 0410 029	• 4,1	29	36	74	6	174,00
29 0121 0420 029	• 4,2	29	36	74	6	174,00
29 0121 0430 029	• 4,3	29	36	74	6	174,00
29 0121 0440 029	• 4,4	29	36	74	6	174,00
29 0121 0450 029	• 4,5	29	36	74	6	174,00
29 0121 0460 029	• 4,6	29	36	74	6	174,00
29 0121 0470 029	• 4,7	29	36	74	6	174,00
29 0121 04763 029	• 4,763	29	36	74	6	177,00
29 0121 0480 029	• 4,8	29	36	74	6	174,00
29 0121 0490 029	• 4,9	29	36	74	6	174,00
29 0121 0500 035	• 5,0	35	44	82	6	185,00
29 0121 0510 035	• 5,1	35	44	82	6	185,00
29 0121 0520 035	• 5,2	35	44	82	6	185,00
29 0121 0530 035	• 5,3	35	44	82	6	185,00
29 0121 0540 035	• 5,4	35	44	82	6	185,00
29 0121 0550 035	• 5,5	35	44	82	6	185,00
29 0121 0560 035	• 5,6	35	44	82	6	185,00
29 0121 0570 035	• 5,7	35	44	82	6	185,00
29 0121 0580 035	• 5,8	35	44	82	6	185,00
29 0121 0590 035	• 5,9	35	44	82	6	185,00

Diamantbeschichtete VHM-Hochleistungsbohrer mit Innenkühlung für CFK/GFK – unidirektional – mit 90° Spitzwinkel vermeidet Delamination

29 0122

Diamond-coated solid-carbide drill with interior cooling for CFRP/GFRP – unidirectional – with 90° tip angle, prevents delamination

GRAPHIT graphite	PVDF GF25
COMPO-SITES	ZIRKON OXID ZIRCONIA
CFK CFRP	FR 4
GFK GFRP	
PEEK CF30	
PEEK GF30	
GF GF25	

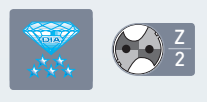
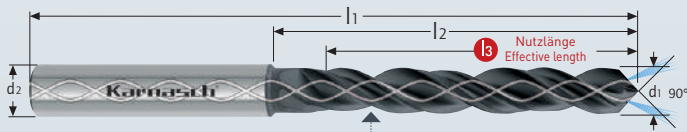

Durch 2 Führungsphasen ist eine sehr hohe Präzision der Bohrungen möglich, bei gleichzeitiger Vermeidung von Delamination.

With 2 guide chamfer is a very high precision of the holes possible, by avoiding of delamination.

Empfohlene Schnittdaten / Recommended cutting data

Werkstoffgruppe Material group	WERKSTOFF WORKPIECE MATERIAL	vc m/min	f mm/U			
			Ø 3,0 - 4,9	Ø 5,0 - 7,9	Ø 8,0 - 9,9	Ø 10,0 - 12,0
8.3	GFK / CFK Composites	160	0,04	0,05	0,07	0,1

Schnittdaten  
Cutting data

Zeichnungen  
Drawings

291

DXF/STEP



UNIDIREKTIONAL  
Faserverlauf in eine Richtung  
Fibre progress in one direction

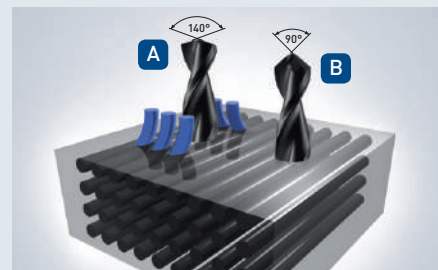

A Delamination und Gratbildung mit konventionellen Bohrern.  
B Sauberer Bohrungsaustritt durch optimierte Führungsphase des Bohrerwerkzeuges.

Art.	d1 m7	l3	l2	l1	d2 h6	€
29 0122 0600 035	• 6,00	35	44	82	6	232,00
29 0122 0610 043	• 6,10	43	53	91	8	288,00
29 0122 0620 043	• 6,20	43	53	91	8	288,00
29 0122 0630 043	• 6,30	43	53	91	8	288,00
29 0122 0635 043	• 6,350 1/4"	43	53	91	8	288,00
29 0122 0640 043	• 6,40	43	53	91	8	288,00
29 0122 0650 043	• 6,50	43	53	91	8	288,00
29 0122 0660 043	• 6,60	43	53	91	8	288,00
29 0122 0670 043	• 6,70	43	53	91	8	288,00
29 0122 0680 043	• 6,80	43	53	91	8	288,00
29 0122 0690 043	• 6,90	43	53	91	8	288,00
29 0122 0700 043	• 7,00	43	53	91	8	288,00
29 0122 0710 043	• 7,10	43	53	91	8	288,00
29 0122 0720 043	• 7,20	43	53	91	8	288,00
29 0122 0730 043	• 7,30	43	53	91	8	288,00
29 0122 0740 043	• 7,40	43	53	91	8	288,00
29 0122 0750 043	• 7,50	43	53	91	8	288,00
29 0122 0760 043	• 7,60	43	53	91	8	288,00
29 0122 0770 043	• 7,70	43	53	91	8	288,00
29 0122 0780 043	• 7,80	43	53	91	8	288,00
29 0122 0790 043	• 7,90	43	53	91	8	288,00
29 0122 07938 043	• 7,938 5/16"	43	53	91	8	288,00
29 0122 0800 043	• 8,00	43	53	91	8	288,00
29 0122 0810 049	• 8,10	49	61	103	10	351,00
29 0122 0820 049	• 8,20	49	61	103	10	351,00
29 0122 0830 049	• 8,30	49	61	103	10	351,00
29 0122 0840 049	• 8,40	49	61	103	10	351,00
29 0122 0850 049	• 8,50	49	61	103	10	351,00
29 0122 0860 049	• 8,60	49	61	103	10	351,00
29 0122 0870 049	• 8,70	49	61	103	10	351,00

Art.	d1 m7	l3	l2	l1	d2 h6	€
29 0122 0880 049	• 8,80	49	61	103	10	351,00
29 0122 0890 049	• 8,90	49	61	103	10	351,00
29 0122 0900 049	• 9,00	49	61	103	10	351,00
29 0122 0910 049	• 9,10	49	61	103	10	351,00
29 0122 0920 049	• 9,20	49	61	103	10	351,00
29 0122 0930 049	• 9,30	49	61	103	10	351,00
29 0122 0940 049	• 9,40	49	61	103	10	351,00
29 0122 0950 049	• 9,50	49	61	103	10	351,00
29 0122 09525 049	• 9,525 3/8"	49	61	103	10	351,00
29 0122 0960 049	• 9,60	49	61	103	10	351,00
29 0122 0970 049	• 9,70	49	61	103	10	351,00
29 0122 0980 049	• 9,80	49	61	103	10	351,00
29 0122 0990 049	• 9,90	49	61	103	10	351,00
29 0122 1000 049	• 10,00	49	61	103	10	351,00
29 0122 1010 056	• 10,10	56	71	118	12	391,00
29 0122 1020 056	• 10,20	56	71	118	12	391,00
29 0122 1030 056	• 10,30	56	71	118	12	391,00
29 0122 1040 056	• 10,40	56	71	118	12	391,00
29 0122 1050 056	• 10,50	56	71	118	12	391,00
29 0122 1060 056	• 10,60	56	71	118	12	391,00
29 0122 1070 056	• 10,70	56	71	118	12	391,00
29 0122 1080 056	• 10,80	56	71	118	12	391,00
29 0122 1090 056	• 10,90	56	71	118	12	391,00
29 0122 1100 056	• 11,00	56	71	118	12	391,00
29 0122 1111 056	• 11,111 7/16"	56	71	118	12	391,00
29 0122 1150 056	• 11,50	56	71	118	12	391,00
29 0122 1180 056	• 11,8	56	71	118	12	391,00
29 0122 1200 056	• 12,0	56	71	118	12	391,00

1

2

3

4

5

6

7

8

9

Index

## 29 0200

CNC-Stack-Drill, VHM-Hochleistungsbohrer mit Innenkühlung CFK/ALU - ALU/CFK  
Solid carbide Stack-drill with interior cooling for CFRP/GFRP-Alu - Alu-CFRP/GFRP

	CFK/GFK - CFRP/GFRP
	Aluminium - Aluminum
	Aluminium - Aluminum
	CFK/GFK - CFRP/GFRP

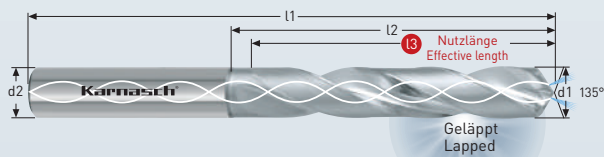

<b>MICRO GRAIN</b>	KARNASCH NORM
<b>SPEZIAL SPECIAL</b>	DIN 6535 Form HAK
	<b>HSC HPC</b>
	<b>GELÄPFT LAPPED</b>
	MMKS



Für den Einsatz auf CNC-Maschinen.

For the use on CNC-machines.

Schnittdaten  
Cutting data

Film  
Movie



1253

Art.	d1 h7	l3	l2	l1	d2 h6	€
29 0200 0300 023	• 3,0	23	28	66	6	114,00
29 0200 0310 023	• 3,1	23	28	66	6	114,00
29 0200 0320 023	• 3,2	23	28	66	6	114,00
29 0200 0330 023	• 3,3	23	28	66	6	114,00
29 0200 0340 023	• 3,4	23	28	66	6	114,00
29 0200 0350 023	• 3,5	23	28	66	6	114,00
29 0200 0360 023	• 3,6	23	28	66	6	114,00
29 0200 0370 023	• 3,7	23	28	66	6	114,00
29 0200 0380 029	• 3,8	29	36	74	6	116,00
29 0200 0390 029	• 3,9	29	36	74	6	116,00
29 0200 0400 029	• 4,0	29	36	74	6	116,00
29 0200 0410 029	• 4,1	29	36	74	6	116,00
29 0200 04176 029	• 4,176	29	36	74	6	117,00
29 0200 0420 029	• 4,2	29	36	74	6	116,00
29 0200 0430 029	• 4,3	29	36	74	6	116,00
29 0200 0440 029	• 4,4	29	36	74	6	116,00
29 0200 0450 029	• 4,5	29	36	74	6	116,00
29 0200 0460 029	• 4,6	29	36	74	6	116,00
29 0200 0470 029	• 4,7	29	36	74	6	116,00
29 0200 0480 029	• 4,8	29	36	74	6	116,00
29 0200 04837 029	• 4,837	29	36	74	6	117,00
29 0200 0490 035	• 4,9	35	44	82	6	119,00
29 0200 0500 035	• 5,0	35	44	82	6	119,00
29 0200 0510 035	• 5,1	35	44	82	6	119,00
29 0200 0520 035	• 5,2	35	44	82	6	119,00
29 0200 0530 035	• 5,3	35	44	82	6	119,00
29 0200 0540 035	• 5,4	35	44	82	6	119,00
29 0200 0550 035	• 5,5	35	44	82	6	119,00
29 0200 05550 035	• 5,55	35	44	82	6	120,00
29 0200 05565 035	• 5,565	35	44	82	6	120,00
29 0200 0560 035	• 5,6	35	44	82	6	119,00
29 0200 0570 035	• 5,7	35	44	82	6	119,00
29 0200 0580 035	• 5,8	35	44	82	6	120,00
29 0200 0590 035	• 5,9	35	44	82	6	119,00
29 0200 0600 035	• 6,0	35	44	82	6	128,00
29 0200 0610 043	• 6,1	43	53	91	8	128,00
29 0200 0620 043	• 6,2	43	53	91	8	128,00
29 0200 0630 043	• 6,3	43	53	91	8	128,00
29 0200 06365 043	• 6,365	43	53	91	8	129,00
29 0200 0640 043	• 6,4	43	53	91	8	128,00
29 0200 0650 043	• 6,5	43	53	91	8	128,00
29 0200 0660 043	• 6,6	43	53	91	8	128,00
29 0200 0670 043	• 6,7	43	53	91	8	128,00
29 0200 0680 043	• 6,8	43	53	91	8	128,00
29 0200 0690 043	• 6,9	43	53	91	8	128,00
29 0200 0700 043	• 7,0	43	53	91	8	128,00
29 0200 0710 043	• 7,1	43	53	91	8	128,00
29 0200 0720 043	• 7,2	43	53	91	8	128,00
29 0200 0730 043	• 7,3	43	53	91	8	128,00
29 0200 0740 043	• 7,4	43	53	91	8	128,00

Art.	d1 h7	l3	l2	l1	d2 h6	€
29 0200 0750 043	• 7,5	43	53	91	8	128,00
29 0200 0760 043	• 7,6	43	53	91	8	128,00
29 0200 0770 043	• 7,7	43	53	91	8	128,00
29 0200 0780 043	• 7,8	43	53	91	8	128,00
29 0200 0790 043	• 7,9	43	53	91	8	128,00
29 0200 07953 043	• 7,953	43	53	91	8	129,00
29 0200 0800 043	• 8,0	43	53	91	8	128,00
29 0200 0810 049	• 8,1	49	61	103	10	185,00
29 0200 0820 049	• 8,2	49	61	103	10	185,00
29 0200 0830 049	• 8,3	49	61	103	10	185,00
29 0200 0840 049	• 8,4	49	61	103	10	185,00
29 0200 0850 049	• 8,5	49	61	103	10	185,00
29 0200 0860 049	• 8,6	49	61	103	10	185,00
29 0200 0870 049	• 8,7	49	61	103	10	185,00
29 0200 0880 049	• 8,8	49	61	103	10	185,00
29 0200 0890 049	• 8,9	49	61	103	10	185,00
29 0200 0900 049	• 9,0	49	61	103	10	185,00
29 0200 0910 049	• 9,1	49	61	103	10	185,00
29 0200 0920 049	• 9,2	49	61	103	10	185,00
29 0200 0930 049	• 9,3	49	61	103	10	185,00
29 0200 0940 049	• 9,4	49	61	103	10	185,00
29 0200 0950 049	• 9,5	49	61	103	10	185,00
29 0200 09540 049	• 9,540	49	61	103	10	187,00
29 0200 0960 049	• 9,6	49	61	103	10	185,00
29 0200 0970 049	• 9,7	49	61	103	10	185,00
29 0200 0980 049	• 9,8	49	61	103	10	185,00
29 0200 0990 049	• 9,9	49	61	103	10	185,00
29 0200 1000 049	• 10,0	49	61	103	10	185,00
29 0200 1010 056	• 10,1	56	71	118	12	256,00
29 0200 1020 056	• 10,2	56	71	118	12	256,00
29 0200 1030 056	• 10,3	56	71	118	12	256,00
29 0200 1040 056	• 10,4	56	71	118	12	256,00
29 0200 1050 056	• 10,5	56	71	118	12	256,00
29 0200 1060 056	• 10,6	56	71	118	12	256,00
29 0200 1070 056	• 10,7	56	71	118	12	256,00
29 0200 1080 056	• 10,8	56	71	118	12	256,00
29 0200 1090 056	• 10,9	56	71	118	12	256,00
29 0200 1100 056	• 11,0	56	71	118	12	256,00
29 0200 1110 056	• 11,1	56	71	118	12	256,00
29 0200 11133 056	• 11,133	56	71	118	12	259,00
29 0200 1120 056	• 11,2	56	71	118	12	256,00
29 0200 1130 056	• 11,3	56	71	118	12	256,00
29 0200 1140 056	• 11,4	56	71	118	12	256,00
29 0200 1150 056	• 11,5	56	71	118	12	256,00
29 0200 1160 056	• 11,6	56	71	118	12	256,00
29 0200 1170 056	• 11,7	56	71	118	12	256,00
29 0200 1180 056	• 11,8	56	71	118	12	256,00
29 0200 1190 056	• 11,9	56	71	118	12	256,00
29 0200 1200 056	• 12,0	56	71	118	12	256,00

CNC-Stack-Drill, VHM-Hochleistungsbohrer mit Innenkühlung CFK/TITAN – TITAN/CFK  
Solid carbide Stack-drill with interior cooling for CFRP/GFRP-Titan – Titan-CFRP/GFRP

29 0210

<b>C</b>	CFK/GFK - CFRP/GFRP
<b>T</b>	Titan - Titanium
<b>T</b>	Titan - Titanium
<b>C</b>	CFK/GFK - CFRP/GFRP

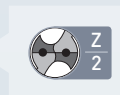
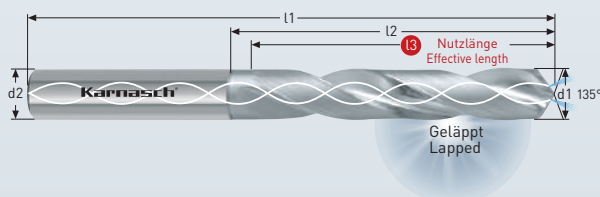

<b>MICRO GRAIN</b>	KARNASCH NORM
<b>SPEZIAL SPECIAL</b>	DIN 6535 Form HAK
	<b>HSC HPC</b>
	<b>GELÄPFT LAPPED</b>
	<b>MMKS</b>



Schnittdaten Cutting data	Film Movie
1253	

Art.	d1 h7	<b>l3</b>	l2	l1	d2 h6	€
29 0210 0300 023	• 3,0	<b>23</b>	28	66	6	120,00
29 0210 0310 023	• 3,1	<b>23</b>	28	66	6	120,00
29 0210 0320 023	• 3,2	<b>23</b>	28	66	6	120,00
29 0210 0330 023	• 3,3	<b>23</b>	28	66	6	120,00
29 0210 0340 023	• 3,4	<b>23</b>	28	66	6	120,00
29 0210 0350 023	• 3,5	<b>23</b>	28	66	6	120,00
29 0210 0360 023	• 3,6	<b>23</b>	28	66	6	120,00
29 0210 0370 023	• 3,7	<b>23</b>	28	66	6	120,00
29 0210 0380 029	• 3,8	<b>29</b>	36	74	6	122,00
29 0210 0390 029	• 3,9	<b>29</b>	36	74	6	122,00
29 0210 0400 029	• 4,0	<b>29</b>	36	74	6	122,00
29 0210 0410 029	• 4,1	<b>29</b>	36	74	6	122,00
29 0210 04176 029	• 4,176	<b>29</b>	36	74	6	124,00
29 0210 0420 029	• 4,2	<b>29</b>	36	74	6	122,00
29 0210 0430 029	• 4,3	<b>29</b>	36	74	6	122,00
29 0210 0440 029	• 4,4	<b>29</b>	36	74	6	122,00
29 0210 0450 029	• 4,5	<b>29</b>	36	74	6	122,00
29 0210 0460 029	• 4,6	<b>29</b>	36	74	6	122,00
29 0210 0470 029	• 4,7	<b>29</b>	36	74	6	122,00
29 0210 0480 029	• 4,8	<b>29</b>	36	74	6	122,00
29 0210 04837 029	• 4,837	<b>29</b>	36	74	6	124,00
29 0210 0490 035	• 4,9	<b>35</b>	44	82	6	125,00
29 0210 0500 035	• 5,0	<b>35</b>	44	82	6	125,00
29 0210 0510 035	• 5,1	<b>35</b>	44	82	6	125,00
29 0210 0520 035	• 5,2	<b>35</b>	44	82	6	125,00
29 0210 0530 035	• 5,3	<b>35</b>	44	82	6	125,00
29 0210 0540 035	• 5,4	<b>35</b>	44	82	6	125,00
29 0210 0550 035	• 5,5	<b>35</b>	44	82	6	125,00
29 0210 0555 035	• 5,55	<b>35</b>	44	82	6	125,00
29 0210 05565 035	• 5,565	<b>35</b>	44	82	6	127,00
29 0210 0560 035	• 5,6	<b>35</b>	44	82	6	125,00
29 0210 0570 035	• 5,7	<b>35</b>	44	82	6	125,00
29 0210 0580 035	• 5,8	<b>35</b>	44	82	6	125,00
29 0210 0590 035	• 5,9	<b>35</b>	44	82	6	125,00
29 0210 0600 035	• 6,0	<b>35</b>	44	82	6	125,00
29 0210 0610 043	• 6,1	<b>43</b>	53	91	8	134,00
29 0210 0620 043	• 6,2	<b>43</b>	53	91	8	134,00
29 0210 0630 043	• 6,3	<b>43</b>	53	91	8	134,00
29 0210 06365 043	• 6,365	<b>43</b>	53	91	8	136,00
29 0210 0640 043	• 6,4	<b>43</b>	53	91	8	134,00
29 0210 0650 043	• 6,5	<b>43</b>	53	91	8	134,00
29 0210 0660 043	• 6,6	<b>43</b>	53	91	8	134,00
29 0210 0670 043	• 6,7	<b>43</b>	53	91	8	134,00
29 0210 0680 043	• 6,8	<b>43</b>	53	91	8	134,00
29 0210 0690 043	• 6,9	<b>43</b>	53	91	8	134,00
29 0210 0700 043	• 7,0	<b>43</b>	53	91	8	134,00
29 0210 0710 043	• 7,1	<b>43</b>	53	91	8	134,00
29 0210 0720 043	• 7,2	<b>43</b>	53	91	8	134,00
29 0210 0730 043	• 7,3	<b>43</b>	53	91	8	134,00
29 0210 0740 043	• 7,4	<b>43</b>	53	91	8	134,00

Art.	d1 h7	<b>l3</b>	l2	l1	d2 h6	€
29 0210 0750 043	• 7,5	<b>43</b>	53	91	8	134,00
29 0210 0760 043	• 7,6	<b>43</b>	53	91	8	134,00
29 0210 0770 043	• 7,7	<b>43</b>	53	91	8	134,00
29 0210 0780 043	• 7,8	<b>43</b>	53	91	8	134,00
29 0210 0790 043	• 7,9	<b>43</b>	53	91	8	134,00
29 0210 07953 043	• 7,953	<b>43</b>	53	91	8	136,00
29 0210 0800 043	• 8,0	<b>43</b>	53	91	8	134,00
29 0210 0810 049	• 8,1	<b>49</b>	61	103	10	193,00
29 0210 0820 049	• 8,2	<b>49</b>	61	103	10	193,00
29 0210 0830 049	• 8,3	<b>49</b>	61	103	10	193,00
29 0210 0840 049	• 8,4	<b>49</b>	61	103	10	193,00
29 0210 0850 049	• 8,5	<b>49</b>	61	103	10	193,00
29 0210 0860 049	• 8,6	<b>49</b>	61	103	10	193,00
29 0210 0870 049	• 8,7	<b>49</b>	61	103	10	193,00
29 0210 0880 049	• 8,8	<b>49</b>	61	103	10	193,00
29 0210 0890 049	• 8,9	<b>49</b>	61	103	10	193,00
29 0210 0900 049	• 9,0	<b>49</b>	61	103	10	193,00
29 0210 0910 049	• 9,1	<b>49</b>	61	103	10	193,00
29 0210 0920 049	• 9,2	<b>49</b>	61	103	10	193,00
29 0210 0930 049	• 9,3	<b>49</b>	61	103	10	193,00
29 0210 0940 049	• 9,4	<b>49</b>	61	103	10	193,00
29 0210 0950 049	• 9,5	<b>49</b>	61	103	10	193,00
29 0210 09540 049	• 9,54	<b>49</b>	61	103	10	195,00
29 0210 0960 049	• 9,6	<b>49</b>	61	103	10	193,00
29 0210 0970 049	• 9,7	<b>49</b>	61	103	10	193,00
29 0210 0980 049	• 9,8	<b>49</b>	61	103	10	193,00
29 0210 0990 049	• 9,9	<b>49</b>	61	103	10	193,00
29 0210 1000 049	• 10,0	<b>49</b>	61	103	10	193,00
29 0210 1010 056	• 10,1	<b>56</b>	71	118	12	269,00
29 0210 1020 056	• 10,2	<b>56</b>	71	118	12	269,00
29 0210 1030 056	• 10,3	<b>56</b>	71	118	12	269,00
29 0210 1040 056	• 10,4	<b>56</b>	71	118	12	269,00
29 0210 1050 056	• 10,5	<b>56</b>	71	118	12	269,00
29 0210 1060 056	• 10,6	<b>56</b>	71	118	12	269,00
29 0210 1070 056	• 10,7	<b>56</b>	71	118	12	269,00
29 0210 1080 056	• 10,8	<b>56</b>	71	118	12	269,00
29 0210 1090 056	• 10,9	<b>56</b>	71	118	12	269,00
29 0210 1100 056	• 11,0	<b>56</b>	71	118	12	269,00
29 0210 1110 056	• 11,1	<b>56</b>	71	118	12	269,00
29 0210 11133 056	• 11,133	<b>56</b>	71	118	12	272,00
29 0210 1120 056	• 11,2	<b>56</b>	71	118	12	269,00
29 0210 1130 056	• 11,3	<b>56</b>	71	118	12	269,00
29 0210 1140 056	• 11,4	<b>56</b>	71	118	12	269,00
29 0210 1150 056	• 11,5	<b>56</b>	71	118	12	269,00
29 0210 1160 056	• 11,6	<b>56</b>	71	118	12	269,00
29 0210 1170 056	• 11,7	<b>56</b>	71	118	12	269,00
29 0210 1180 056	• 11,8	<b>56</b>	71	118	12	269,00
29 0210 1190 056	• 11,9	<b>56</b>	71	118	12	269,00
29 0210 1200 056	• 12,0	<b>56</b>	71	118	12	269,00



## 29 0250

ROBO-Stack-Drill, VHM-Hochleistungsbohrer mit Innenkühlung CFK/ALU - ALU/CFK  
Solid carbide ROBO-Stack-drill with interior cooling for CFRP/GFRP-Alu - Alu-CFRP/GFRP

	CFK/GFK - CFRP/GFRP
	Aluminium - Aluminum
	Aluminium - Aluminum
	CFK/GFK - CFRP/GFRP

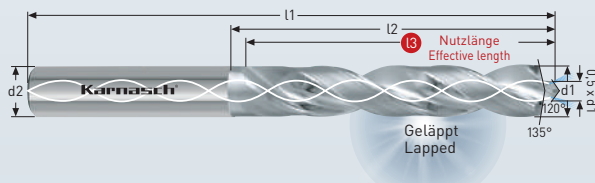

<b>MICRO GRAIN</b>	KARNASCH NORM
<b>SPEZIAL</b>	DIN 6535 Form HAK
	<b>HSC HPC</b>
	<b>GELÄPPT LAPPED</b>
	MMKS



Schnittdaten Cutting data

Film Movie

1253

Art.	d1 h7	l3	l2	l1	d2 h6	€
29 0250 0800 043	• 8,0	43	53	91	8	142,00
29 0250 0810 049	• 8,1	49	61	103	10	203,00
29 0250 0820 049	• 8,2	49	61	103	10	203,00
29 0250 0830 049	• 8,3	49	61	103	10	203,00
29 0250 0840 049	• 8,4	49	61	103	10	203,00
29 0250 0850 049	• 8,5	49	61	103	10	203,00
29 0250 0860 049	• 8,6	49	61	103	10	203,00
29 0250 0870 049	• 8,7	49	61	103	10	203,00
29 0250 0880 049	• 8,8	49	61	103	10	203,00
29 0250 0890 049	• 8,9	49	61	103	10	203,00
29 0250 0900 049	• 9,0	49	61	103	10	203,00
29 0250 0910 049	• 9,1	49	61	103	10	203,00
29 0250 0920 049	• 9,2	49	61	103	10	203,00
29 0250 0930 049	• 9,3	49	61	103	10	203,00
29 0250 0940 049	• 9,4	49	61	103	10	203,00
29 0250 0950 049	• 9,5	49	61	103	10	203,00
29 0250 0954 049	• 9,54	49	61	103	10	203,00
29 0250 0960 049	• 9,6	49	61	103	10	203,00
29 0250 0970 049	• 9,7	49	61	103	10	203,00
29 0250 0980 049	• 9,8	49	61	103	10	203,00
29 0250 0990 049	• 9,9	49	61	103	10	203,00
29 0250 1000 049	• 10,0	49	61	103	10	203,00
29 0250 1010 056	• 10,1	56	71	118	12	283,00
29 0250 1020 056	• 10,2	56	71	118	12	283,00
29 0250 1030 056	• 10,3	56	71	118	12	283,00
29 0250 1040 056	• 10,4	56	71	118	12	283,00
29 0250 1050 056	• 10,5	56	71	118	12	283,00
29 0250 1060 056	• 10,6	56	71	118	12	283,00
29 0250 1070 056	• 10,7	56	71	118	12	283,00
29 0250 1080 056	• 10,8	56	71	118	12	283,00
29 0250 1090 056	• 10,9	56	71	118	12	283,00
29 0250 1100 056	• 11,0	56	71	118	12	283,00
29 0250 1110 056	• 11,1	56	71	118	12	283,00
29 0250 11133 056	• 11,133	56	71	118	12	287,00
29 0250 1120 056	• 11,2	56	71	118	12	283,00
29 0250 1130 056	• 11,3	56	71	118	12	283,00
29 0250 1140 056	• 11,4	56	71	118	12	283,00
29 0250 1150 056	• 11,5	56	71	118	12	283,00
29 0250 1160 056	• 11,6	56	71	118	12	283,00
29 0250 1170 056	• 11,7	56	71	118	12	283,00
29 0250 1180 056	• 11,8	56	71	118	12	283,00
29 0250 1190 056	• 11,9	56	71	118	12	283,00
29 0250 1200 056	• 12,0	56	71	118	12	283,00
29 0250 1210 060	• 12,1	60	77	124	14	380,00
29 0250 1220 060	• 12,2	60	77	124	14	380,00
29 0250 1230 060	• 12,3	60	77	124	14	380,00
29 0250 1240 060	• 12,4	60	77	124	14	380,00
29 0250 1250 060	• 12,5	60	77	124	14	380,00
29 0250 1260 060	• 12,6	60	77	124	14	380,00
29 0250 1270 060	• 12,7	60	77	124	14	380,00
29 0250 1272 060	• 12,72	60	77	124	14	380,00
29 0250 1280 060	• 12,8	60	77	124	14	380,00
29 0250 1290 060	• 12,9	60	77	124	14	380,00
29 0250 1300 060	• 13,0	60	77	124	14	380,00
29 0250 1310 060	• 13,1	60	77	124	14	380,00
29 0250 1320 060	• 13,2	60	77	124	14	380,00
29 0250 1330 060	• 13,3	60	77	124	14	380,00
29 0250 1340 060	• 13,4	60	77	124	14	380,00
29 0250 1350 060	• 13,5	60	77	124	14	380,00
29 0250 1360 060	• 13,6	60	77	124	14	380,00
29 0250 1370 060	• 13,7	60	77	124	14	380,00
29 0250 1380 060	• 13,8	60	77	124	14	380,00
29 0250 1390 060	• 13,9	60	77	124	14	380,00
29 0250 1400 060	• 14,0	60	77	124	14	380,00

Art.	d1 h7	l3	l2	l1	d2 h6	€
29 0250 1410 063	• 14,1	63	83	133	16	469,00
29 0250 1420 063	• 14,2	63	83	133	16	469,00
29 0250 14295 063	• 14,295	63	83	133	16	476,00
29 0250 1430 063	• 14,3	63	83	133	16	469,00
29 0250 1440 063	• 14,4	63	83	133	16	469,00
29 0250 1450 063	• 14,5	63	83	133	16	469,00
29 0250 1460 063	• 14,6	63	83	133	16	469,00
29 0250 1470 063	• 14,7	63	83	133	16	469,00
29 0250 1480 063	• 14,8	63	83	133	16	469,00
29 0250 1490 063	• 14,9	63	83	133	16	469,00
29 0250 1500 063	• 15,0	63	83	133	16	469,00
29 0250 1510 063	• 15,1	63	83	133	16	469,00
29 0250 1520 063	• 15,2	63	83	133	16	469,00
29 0250 1530 063	• 15,3	63	83	133	16	469,00
29 0250 1540 063	• 15,4	63	83	133	16	469,00
29 0250 1550 063	• 15,5	63	83	133	16	469,00
29 0250 1560 063	• 15,6	63	83	133	16	469,00
29 0250 1570 063	• 15,7	63	83	133	16	469,00
29 0250 1580 063	• 15,8	63	83	133	16	469,00
29 0250 15882 063	• 15,882	63	83	133	16	476,00
29 0250 1590 063	• 15,9	63	83	133	16	469,00
29 0250 1600 063	• 16,0	63	83	133	16	469,00
29 0250 1610 071	• 16,1	71	93	143	18	620,00
29 0250 1620 071	• 16,2	71	93	143	18	620,00
29 0250 1630 071	• 16,3	71	93	143	18	620,00
29 0250 1640 071	• 16,4	71	93	143	18	620,00
29 0250 1650 071	• 16,5	71	93	143	18	620,00
29 0250 1660 071	• 16,6	71	93	143	18	620,00
29 0250 1670 071	• 16,7	71	93	143	18	620,00
29 0250 1680 071	• 16,8	71	93	143	18	620,00
29 0250 1690 071	• 16,9	71	93	143	18	620,00
29 0250 1700 071	• 17,0	71	93	143	18	620,00
29 0250 1710 071	• 17,1	71	93	143	18	620,00
29 0250 1720 071	• 17,2	71	93	143	18	620,00
29 0250 1730 071	• 17,3	71	93	143	18	620,00
29 0250 1740 071	• 17,4	71	93	143	18	620,00
29 0250 1750 071	• 17,5	71	93	143	18	620,00
29 0250 1760 071	• 17,6	71	93	143	18	620,00
29 0250 1770 071	• 17,7	71	93	143	18	620,00
29 0250 1780 071	• 17,8	71	93	143	18	620,00
29 0250 1790 071	• 17,9	71	93	143	18	620,00
29 0250 1800 071	• 18,0	71	93	143	18	620,00
29 0250 1810 077	• 18,1	77	101	153	20	763,00
29 0250 1820 077	• 18,2	77	101	153	20	763,00
29 0250 1830 077	• 18,3	77	101	153	20	763,00
29 0250 1840 077	• 18,4	77	101	153	20	763,00
29 0250 1850 077	• 18,5	77	101	153	20	763,00
29 0250 1860 077	• 18,6	77	101	153	20	763,00
29 0250 1870 077	• 18,7	77	101	153	20	763,00
29 0250 1880 077	• 18,8	77	101	153	20	763,00
29 0250 1890 077	• 18,9	77	101	153	20	763,00
29 0250 1900 077	• 19,0	77	101	153	20	763,00
29 0250 19065 077	• 19,065	77	101	153	20	775,00
29 0250 1910 077	• 19,1	77	101	153	20	763,00
29 0250 1920 077	• 19,2	77	101	153	20	763,00
29 0250 1930 077	• 19,3	77	101	153	20	763,00
29 0250 1940 077	• 19,4	77	101	153	20	763,00
29 0250 1950 077	• 19,5	77	101	153	20	763,00
29 0250 1960 077	• 19,6	77	101	153	20	763,00
29 0250 1970 077	• 19,7	77	101	153	20	763,00
29 0250 1980 077	• 19,8	77	101	153	20	763,00
29 0250 1990 077	• 19,9	77	101	153	20	763,00
29 0250 2000 077	• 20,0	77	101	153	20	763,00

ROBO-Stack-Drill, VHM-Hochleistungsbohrer mit Innenkühlung CFK/TITAN – TITAN/CFK  
Solid carbide ROBO-Stack-drill with interior cooling for CFRP/GFRP-Titan – Titan-CFRP/GFRP

29 0260

<b>C</b>	CFK/GFK - CFRP/GFRP
<b>T</b>	Titan - Titanium
<b>T</b>	Titan - Titanium
<b>C</b>	CFK/GFK - CFRP/GFRP

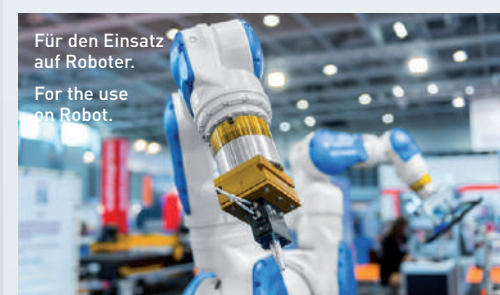
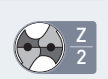
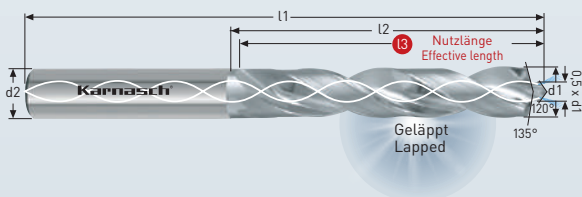

Schnittdaten Cutting data [i](#) 1253

Film Movie [▶](#)

**MICRO GRAIN** KARNASCH NORM

**SPEZIAL** DIN 6535 Form HAK

34° 135°

**HSC HPC**

**GELÄPPT LAPPED**

MMKS

Art.	d1 h7	l3	l2	l1	d2 h6	€
29 0260 0800 043	• 8,0	43	53	91	8	150,00
29 0260 0810 049	• 8,1	49	61	103	10	212,00
29 0260 0820 049	• 8,2	49	61	103	10	212,00
29 0260 0830 049	• 8,3	49	61	103	10	212,00
29 0260 0840 049	• 8,4	49	61	103	10	212,00
29 0260 0850 049	• 8,5	49	61	103	10	212,00
29 0260 0860 049	• 8,6	49	61	103	10	212,00
29 0260 0870 049	• 8,7	49	61	103	10	212,00
29 0260 0880 049	• 8,8	49	61	103	10	212,00
29 0260 0890 049	• 8,9	49	61	103	10	212,00
29 0260 0900 049	• 9,0	49	61	103	10	212,00
29 0260 0910 049	• 9,1	49	61	103	10	212,00
29 0260 0920 049	• 9,2	49	61	103	10	212,00
29 0260 0930 049	• 9,3	49	61	103	10	212,00
29 0260 0940 049	• 9,4	49	61	103	10	212,00
29 0260 0950 049	• 9,5	49	61	103	10	212,00
29 0260 0954 049	• 9,54	49	61	103	10	212,00
29 0260 0960 049	• 9,6	49	61	103	10	212,00
29 0260 0970 049	• 9,7	49	61	103	10	212,00
29 0260 0980 049	• 9,8	49	61	103	10	212,00
29 0260 0990 049	• 9,9	49	61	103	10	212,00
29 0260 1000 049	• 10,0	49	61	103	10	212,00
29 0260 1010 056	• 10,1	56	71	118	12	296,00
29 0260 1020 056	• 10,2	56	71	118	12	296,00
29 0260 1030 056	• 10,3	56	71	118	12	296,00
29 0260 1040 056	• 10,4	56	71	118	12	296,00
29 0260 1050 056	• 10,5	56	71	118	12	296,00
29 0260 1060 056	• 10,6	56	71	118	12	296,00
29 0260 1070 056	• 10,7	56	71	118	12	296,00
29 0260 1080 056	• 10,8	56	71	118	12	296,00
29 0260 1090 056	• 10,9	56	71	118	12	296,00
29 0260 1100 056	• 11,0	56	71	118	12	296,00
29 0260 1110 056	• 11,1	56	71	118	12	296,00
29 0260 1113 056	• 11,13	56	71	118	12	296,00
29 0260 1120 056	• 11,2	56	71	118	12	296,00
29 0260 1130 056	• 11,3	56	71	118	12	296,00
29 0260 1140 056	• 11,4	56	71	118	12	296,00
29 0260 1150 056	• 11,5	56	71	118	12	296,00
29 0260 1160 056	• 11,6	56	71	118	12	296,00
29 0260 1170 056	• 11,7	56	71	118	12	296,00
29 0260 1180 056	• 11,8	56	71	118	12	296,00
29 0260 1190 056	• 11,9	56	71	118	12	296,00
29 0260 1200 056	• 12,0	56	71	118	12	296,00
29 0260 1210 060	• 12,1	60	77	124	14	398,00
29 0260 1220 060	• 12,2	60	77	124	14	398,00
29 0260 1230 060	• 12,3	60	77	124	14	398,00
29 0260 1240 060	• 12,4	60	77	124	14	398,00
29 0260 1250 060	• 12,5	60	77	124	14	398,00
29 0260 1260 060	• 12,6	60	77	124	14	398,00
29 0260 1270 060	• 12,7	60	77	124	14	398,00
29 0260 1272 060	• 12,72	60	77	124	14	398,00
29 0260 1280 060	• 12,8	60	77	124	14	398,00
29 0260 1290 060	• 12,9	60	77	124	14	398,00
29 0260 1300 060	• 13,0	60	77	124	14	398,00
29 0260 1310 060	• 13,1	60	77	124	14	398,00
29 0260 1320 060	• 13,2	60	77	124	14	398,00
29 0260 1330 060	• 13,3	60	77	124	14	398,00
29 0260 1340 060	• 13,4	60	77	124	14	398,00
29 0260 1350 060	• 13,5	60	77	124	14	398,00
29 0260 1360 060	• 13,6	60	77	124	14	398,00
29 0260 1370 060	• 13,7	60	77	124	14	398,00
29 0260 1380 060	• 13,8	60	77	124	14	398,00
29 0260 1390 060	• 13,9	60	77	124	14	398,00
29 0260 1400 060	• 14,0	60	77	124	14	398,00

Art.	d1 h7	l3	l2	l1	d2 h6	€
29 0260 1410 063	• 14,1	63	83	133	16	491,00
29 0260 1420 063	• 14,2	63	83	133	16	491,00
29 0260 14295 063	• 14,295	63	83	133	16	499,00
29 0260 1430 063	• 14,3	63	83	133	16	491,00
29 0260 1440 063	• 14,4	63	83	133	16	491,00
29 0260 1450 063	• 14,5	63	83	133	16	491,00
29 0260 1460 063	• 14,6	63	83	133	16	491,00
29 0260 1470 063	• 14,7	63	83	133	16	491,00
29 0260 1480 063	• 14,8	63	83	133	16	491,00
29 0260 1490 063	• 14,9	63	83	133	16	491,00
29 0260 1500 063	• 15,0	63	83	133	16	491,00
29 0260 1510 063	• 15,1	63	83	133	16	491,00
29 0260 1520 063	• 15,2	63	83	133	16	491,00
29 0260 1530 063	• 15,3	63	83	133	16	491,00
29 0260 1540 063	• 15,4	63	83	133	16	491,00
29 0260 1550 063	• 15,5	63	83	133	16	491,00
29 0260 1560 063	• 15,6	63	83	133	16	491,00
29 0260 1570 063	• 15,7	63	83	133	16	491,00
29 0260 1580 063	• 15,8	63	83	133	16	491,00
29 0260 15882 063	• 15,882	63	83	133	16	499,00
29 0260 1590 063	• 15,9	63	83	133	16	491,00
29 0260 1600 063	• 16,0	63	83	133	16	491,00
29 0260 1610 071	• 16,1	71	93	143	18	650,00
29 0260 1620 071	• 16,2	71	93	143	18	650,00
29 0260 1630 071	• 16,3	71	93	143	18	650,00
29 0260 1640 071	• 16,4	71	93	143	18	650,00
29 0260 1650 071	• 16,5	71	93	143	18	650,00
29 0260 1660 071	• 16,6	71	93	143	18	650,00
29 0260 1670 071	• 16,7	71	93	143	18	650,00
29 0260 1680 071	• 16,8	71	93	143	18	650,00
29 0260 1690 071	• 16,9	71	93	143	18	650,00
29 0260 1700 071	• 17,0	71	93	143	18	650,00
29 0260 1710 071	• 17,1	71	93	143	18	650,00
29 0260 1720 071	• 17,2	71	93	143	18	650,00
29 0260 1730 071	• 17,3	71	93	143	18	650,00
29 0260 1740 071	• 17,4	71	93	143	18	650,00
29 0260 1750 071	• 17,5	71	93	143	18	650,00
29 0260 1760 071	• 17,6	71	93	143	18	650,00
29 0260 1770 071	• 17,7	71	93	143	18	650,00
29 0260 1780 071	• 17,8	71	93	143	18	650,00
29 0260 1790 071	• 17,9	71	93	143	18	650,00
29 0260 1800 071	• 18,0	71	93	143	18	650,00
29 0260 1810 077	• 18,1	77	101	153	20	798,00
29 0260 1820 077	• 18,2	77	101	153	20	798,00
29 0260 1830 077	• 18,3	77	101	153	20	798,00
29 0260 1840 077	• 18,4	77	101	153	20	798,00
29 0260 1850 077	• 18,5	77	101	153	20	798,00
29 0260 1860 077	• 18,6	77	101	153	20	798,00
29 0260 1870 077	• 18,7	77	101	153	20	798,00
29 0260 1880 077	• 18,8	77	101	153	20	798,00
29 0260 1890 077	• 18,9	77	101	153	20	798,00
29 0260 1900 077	• 19,0	77	101	153	20	798,00
29 0260 19065 077	• 19,065	77	101	153	20	810,00
29 0260 1910 077	• 19,1	77	101	153	20	798,00
29 0260 1920 077	• 19,2	77	101	153	20	798,00
29 0260 1930 077	• 19,3	77	101	153	20	798,00
29 0260 1940 077	• 19,4	77	101	153	20	798,00
29 0260 1950 077	• 19,5	77	101	153	20	798,00
29 0260 1960 077	• 19,6	77	101	153	20	798,00
29 0260 1970 077	• 19,7	77	101	153	20	798,00
29 0260 1980 077	• 19,8	77	101	153	20	798,00
29 0260 1990 077	• 19,9	77	101	153	20	798,00
29 0260 2000 077	• 20,0	77	101	153	20	798,00

1

2

3

4

5

6

7

8

9

Index



## Ihre Notizen & Zeichnungen Your notices & drafts



Ihr Spezialist für Zerspanungswerkzeuge:

**Karnasch**  
PROFESSIONAL TOOLS  
GERMANY



## ÖSTERREICH:

Grampelhuber GmbH

Koaserbauerstrasse 18

4810 Gmunden / Austria

Telefon: +43 (0)7612 - 64902-0

Telefax: +43 (0)7612 - 64902-8

office@grampelhuber.at

www.grampelhuber.at

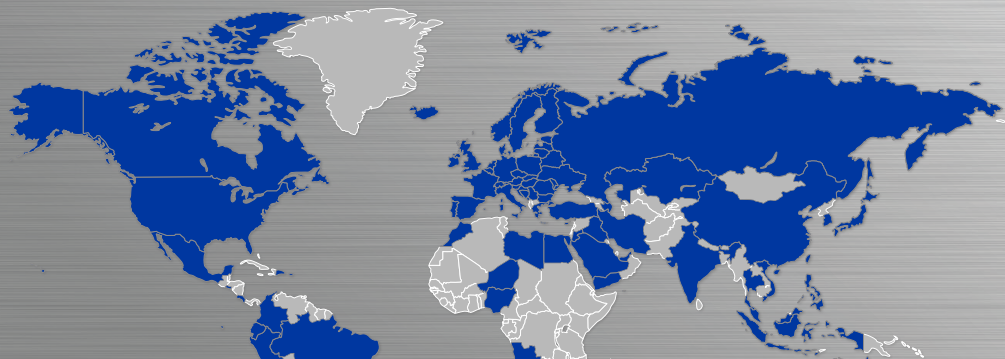

### KARNASCH WORLDWIDE

**EUROPE** AUSTRIA · BELGIUM · BOSNIA HERZEGOVINA · BRITISH VIRGIN ISLANDS · BULGARIA · CROATIA  
CYPRUS · CZECH REPUBLIC · DENMARK · ESTONIA · FAROE ISLANDS · FINLAND · FRANCE · GEORGIA  
GERMANY · GREECE · HUNGARY · ICELAND · IRELAND · ITALY · KOSOVO · LATVIA · LITHUANIA · LUXEMBOURG · MALTA · MOLDOVA  
MONACO · MONTENEGRO · NETHERLANDS · NORWAY · POLAND · PORTUGAL · REPUBLIC OF MOLDOVA · REPUBLIC OF MACEDONIA · ROMANIA  
RUSSIA · SAN MARINO · SLOVAKIA · SLOVENIA · SPAIN · SWEDEN · SWITZERLAND · TURKEY · UKRAINE · UNITED KINGDOM · WHITE RUSSIA/BELARUS  
**AFRICA** ANGOLA · EGYPT · EQUATORIAL GUINEA · LYBIA · MOROCCO · NIGERIA · REPUBLIC OF MAURITIUS · SAUDI ARABIA · SOUTH AFRICA  
UAE/UNITED ARAB EMIRATES · **ASIA** ARMENIA · AZERBAIJAN · CHINA · DEMOCRATIC PEOPLE'S REPUBLIC OF KOREA · GEORGIA · HONG KONG · INDIA  
INDONESIA · IRAN · ISRAEL · JAPAN · JORDAN · KAZAKHSTAN · KUWAIT · LEBANON · MALAYSIA · PHILIPPINES · QATAR · UAE/UNITED ARAB EMIRATES  
SINGAPORE · SYRIA · TAIWAN · THAILAND · TUNESIEN REPUBLIC · VIETNAM · YEMEN · **SOUTH AMERICA** ARGENTINIA · BRAZIL · CHILE · COLOMBIA  
EQUADOR · PERU · REPUBLIC OF VENEZUELA · **AMERICA** AMERICAN SAMOA · CANADA · USA · **MIDDLE AMERICA** COSTA RICA · EL SALVADOR · MEXICO  
**AUSTRALIA · OCEANIA** CALEDONIA · NEW ZEALAND